

A photograph of a stone retaining wall made of large, rough-hewn, reddish-brown stones. A wooden post-and-rail fence runs along the top of the wall. The background shows a grassy hillside with a few evergreen trees under a blue sky with scattered white clouds.

**REDIROCK**

# DESIGN RESOURCE MANUAL



The Redi-Rock logo is a registered trademark of Redi-Rock International, LLC of Charlevoix, MI USA.

The Redi-Rock name is a copyright of Redi-Rock International, LLC of Charlevoix, MI USA.

The information contained in the Design Resource Manual (DRM) has been compiled by Redi-Rock International, LLC to document the performance of the Redi-Rock products contained therein. It is accurate to the best of our knowledge as of the date of its issue. Information included in the DRM has been prepared in accordance with generally recognized engineering principles and practices. This information should not be used without first securing competent advice with respect to its suitability for any general or specific application. Final determination of the suitability of any design information and the appropriateness of this data for a given design purpose is the sole responsibility of the user.

No warranty of performance by Redi-Rock International, LLC or the DRM authors is expressed or implied by the publishing of the following DRM.

# REGISTER YOUR DESIGN RESOURCE MANUAL

You don't want to be the stuck with old news, do you?

We are committed to always providing you with up-to-date information and cutting-edge engineering. By registering your manual, you will ensure your access to the newest technical updates as they become available.

➔ Register at [redi-rock.com/register](https://www.redi-rock.com/register)

# Your



complete  
wall solution.

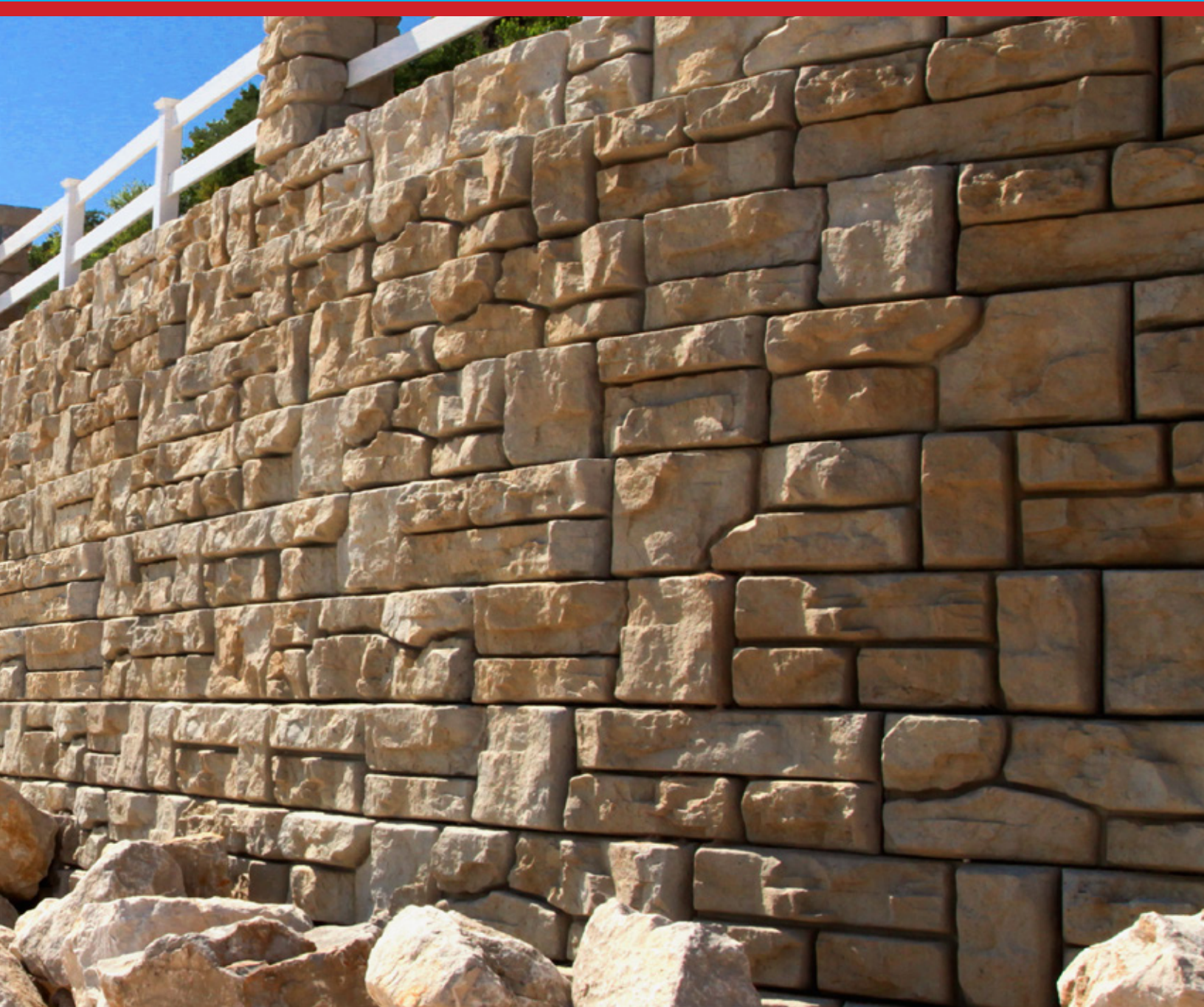

# Table of Contents

---

---

## 8 Introduction and General Info

**10** Letter from Our Chief Engineer  
**12** FAQs

---

---

## 14 Case Studies

**16** Water Application  
**18** PC/Commercial Application  
**20** Residential/Highway Application  
**22** Rail Application  
**24** Storm Channel Application  
**26** Bridge Application

---

---

## 28 Block Library

**30** Block Textures  
**38** Isometric Block Drawings  
*Retaining, Freestanding, Accessories*

---

---

## 60 Design Information

**62** Infilled Unit Weight  
**68** Setback Options  
**70** Interface Shear Design Values  
**72** Geogrid Connection Design Parameters  
**77** Geogrid Packaging, Ordering, and Delivery  
**78** Minimum Turning Radius  
**80** Positive Connection Design Guide Info  
**81** Redi-Rock Wall Analysis Software Info

---

---

## 82 Gravity Walls

**85** Standard Batter Charts  
*34°, 30°, 28°, Stone Backfill (26° Native) - Load Cases A, B, and C*

---

---

## 104 Large Batter Walls

**107** Large Batter Walls with 9" Setback Blocks  
*34°, 30°, 28° - Load Cases A, B, and C*

---

---

---

---

## 126 MSE Walls

**129** Positive Connection Charts  
*34°, 30°, 28° - Load Cases A, B, and CR*

---

---

## 220 Product Data Sheets

**222** 28-Inch Gravity Block  
**224** 41-Inch Gravity Block  
**226** 60-Inch Gravity Block  
**228** 41-Inch Wide 9-Inch Setback Block  
**230** 60-Inch Wide 9-Inch Setback Block  
**232** 28-Inch and 41-Inch PC Block  
**234** Freestanding Straight Block  
**235** Freestanding Variable Radius Block

---

---

## 236 CSI Specifications

---

---

## 264 Installation Guide

---

---

## 286 Construction Details





# GENERAL INFORMATION



**T**hank you for taking the time to review this new *Design Resource Manual*. We feel like it's our best yet. As you evaluate the products offered here, you can count on Redi-Rock® to provide the solutions you need for your projects. With over 130 independently-owned licensed manufacturers located all over the globe, Redi-Rock is the leader of the wet-cast, large-block retaining wall industry.

We strive to provide you with detailed information in a simple, accessible format. It is our goal to make it easy to design Redi-Rock projects with confidence. In

this manual, you will find answers to frequently asked questions, case studies of exciting projects, a detailed library of products, preliminary height guides, detailed design information, specifications, installation instructions, typical details, and much more.

The information in this publication is intended to supplement even more information available anytime on our website at [redi-rock.com](http://redi-rock.com).

Redi-Rock International is committed to providing the highest-quality innovative products that are literally changing the

---

“We strive to provide you with **detailed information** in a **simple, accessible format**. It is our goal to make it easy to design Redi-Rock projects with **confidence**.”

retaining wall industry. If you are not finding what you are looking for or if there is anything we can do for you, please let us know. We are eager to earn and keep your business.

Sincerely,

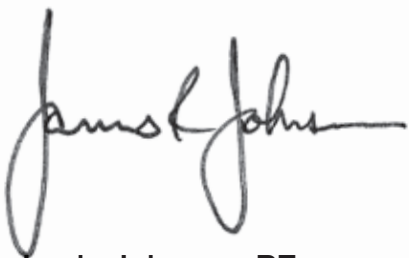
A handwritten signature in black ink, appearing to read "Jamie Johnson". The signature is fluid and cursive, written on a light-colored background.

**Jamie Johnson, PE**  
Chief Engineer  
Redi-Rock International

engineering@redi-rock.com  
(866) 222-8400 ext. 3010

# Frequently Asked Questions

## WHAT IS REDI-ROCK?

Redi-Rock is a line of precast products made from durable, first-purpose, air-entrained, wet-cast concrete. The most common Redi-Rock products are large retaining wall blocks.

Often referred to as one-ton Lego blocks, Redi-Rock blocks vary in width from 28 inches (710 millimeters) to 60 inches (1.52 meters) and in weight from 1,200 pounds (544 kilograms) to 3,500 pounds (1,588 kilograms). In many instances, the Redi-Rock retaining wall blocks are big enough that they can be simply stacked on top of each other to construct a “gravity” wall. For even taller and/or more heavily loaded retaining walls, the Redi-Rock Positive Connection (PC) System can be used to construct a Mechanically Stabilized Earth (MSE) wall.

However, Redi-Rock is much more than simply large retaining wall blocks. Redi-Rock freestanding blocks have the same great look as the retaining blocks, with texture on two or more sides. These freestanding blocks are perfect for perimeter walls, entrance monuments, or parapet walls. Redi-Rock accessory products

include column blocks, steps, and caps. These accessories are perfect for completing your project. We even have products like Pole Base® concrete foundations for light poles, driveway monuments, and signs.

## WHO MAKES REDI-ROCK PRODUCTS?

Redi-Rock products are produced by over 130 independently-owned manufacturers located all over the globe. Contact information for the Redi-Rock manufacturer in your area is available anytime at [redi-rock.com](http://redi-rock.com).

## WHO DESIGNS REDI-ROCK RETAINING WALLS?

The answer to this question depends on what you are trying to accomplish. If you want to get a good idea of how Redi-Rock products can work for your project, the preliminary height guides in this *Design Resource Manual* are a great place to start. These guides show Redi-Rock wall sections in different assumed soil and loading conditions, and they can quickly help you determine what sections will likely work for your particular project.

When you want to build a wall, there simply is no substitute for detailed

plans prepared by a licensed engineer who routinely designs retaining walls. Licensed professionals have proven themselves with years of study and practice, and they are uniquely qualified to create an optimal design for the specific conditions of your project. In addition, a seal of the calculations and design drawings by a “Design Professional of Responsible Charge” is generally required by the International Building Code (Section 105.2) for all walls over four feet in height.

## WHO INSTALLS REDI-ROCK RETAINING WALLS?

Redi-Rock walls are typically constructed by earth excavating contractors or landscaping contractors using large pieces of earth-moving equipment. General contractors that have experience building Redi-Rock walls can be excellent resources for your project. Your local Redi-Rock manufacturer will often have close working relationships with the wall installers in your area and can be a great source of information.

Wondering how to install Redi-Rock? We can help there, too. Redi-Rock has a detailed *Installation Manual* that covers the basic installation

steps. We also have several typical construction details showing how to build common things like 90-degree corners, curves, barriers, or other features in your wall. These resources are available in this *Design Resource Manual* and online at [redi-rock.com](http://redi-rock.com).

## HOW MUCH DO REDI-ROCK WALLS COST?

Since every project is different, there is no single price for a Redi-Rock wall. Several things must be accounted for, including material, labor, and shipping costs. Materials include Redi-Rock blocks, drainage aggregates, geotextiles, drain pipes, and possibly even select fill; however, project costs are much more than just the sum of material costs. Although Redi-Rock blocks may have a higher price per unit than smaller, dry-cast retaining wall products or blocks made from inferior materials like return concrete, they provide significant savings due to installation speed and product longevity.

The true cost of a Redi-Rock wall must be evaluated on the cost per area of wall face (dollars per square foot or square meter) of

the completed structure over the full life of the structure. For taller mechanically stabilized earth walls, part of the cost per square unit area of the retaining wall includes the factory cut geogrid strips that are used with the PC blocks. These strips are specifically manufactured and certified for width and strength, providing construction efficiencies and design reliability that add value to your project.

The real value in Redi-Rock retaining walls comes from superior engineering, high-quality products, and unbeatable face textures that lead to extremely robust and attractive structures that will last for a lifetime. It is because of the intricacies and complexities of each unique project that the very best source for pricing is typically from the Redi-Rock manufacturer located closest to your project site. Find the closest manufacturer at [redi-rock.com](http://redi-rock.com).

## WILL REDI-ROCK WORK FOR MY PROJECT?

Redi-Rock has been used with outstanding success on a myriad of different retaining wall applications. Some examples are retaining walls in water applications (seawalls, bank

stabilization, channelization, and detention ponds), bridge abutments, parks, residential projects, commercial projects, highway walls, GRS-IBS structures, and even rail applications. Chances are, someone has already figured out a way to use Redi-Rock on a project just like yours. There are hundreds of case studies available at [redi-rock.com](http://redi-rock.com) that will help you visualize how Redi-Rock can be used to make your project a reality.

## I HAVE MORE QUESTIONS... WHAT SHOULD I DO?

Quite simply, ask. Your local Redi-Rock manufacturer is a great place to start. Often they have working relationships with wall design engineers and local installers. You can also contact Redi-Rock International, either through your local manufacturer or directly by calling **(866) 222-8400** or by email at [engineering@redi-rock.com](mailto:engineering@redi-rock.com). We have engineers on staff who can help answer general design questions, provide specific information about our products, and point you in the right direction to successfully design and install your own outstanding Redi-Rock retaining wall.





# CASE STUDIES

WATER APPLICATION:

# Precast Sea Wall Weathers Massive Storm

## THE CHALLENGE

In the spring of 2012, a massive construction project to transform Rhyl's riverfront area broke ground. Rhyl, located in North Wales on the Irish Sea at the mouth of the River Clwyd, is part of the Wales Coast Path which follows the entire coastline of Wales.

The goal of the project was to increase tourism and boost the local economy, as well as deepening the river channel, enlarging the marina, and providing coastal erosion and flood protection. To accomplish this, the site required a retaining wall solution that could meet the complex structural requirements of the site—including significant tidal fluctuations—while providing a scenic park route for pedestrians and cyclists.

## THE SOLUTION

Designers for the project chose the Redi-Rock® Positive Connection (PC) System to create the harbor wall that stands 7.4 meters (24.3 feet) high and stretches 188 lineal meters (617 feet). Produced locally by Redi-Rock manufacturer CPM Group, the Redi-Rock PC walls were able to meet the structural requirements of the site as well as provide an aesthetic Limestone finish at a lower cost than other options.

“The Redi-Rock product is very simple but massively effective,” said Jamie Turner, Site Agent for general contractor Dawnus Construction. “It is easy to install and the end product looks fantastic. I would definitely use this product again.”

## THE OUTCOME

During the 2013-2014 winter season, the new harbor sea wall was put to the test. For days, a storm battered the United Kingdom and caused a 60-year high tidal surge. January wave heights were close to the 100-year level.

While this massive storm caused damage to many other structures in the area, designers were happy to see that the harbor wall performed exactly as engineered. The city was so impressed with how the Redi-Rock wall performed during the storm, they replaced 1 kilometer (3280 feet) of other nearby walls with Redi-Rock.





PC/COMMERCIAL APPLICATION:

# The Parklands Chooses Redi-Rock for Multi-Phase Project

## THE CHALLENGE

Creating a 21-mile (33.8-kilometer) long park system that encompasses more than 3,800 acres (1538 hectares) is no small task. But that's just what 21st Century Parks set out to do in 2010. The Parklands is an extensive park system in the Louisville, KY area that includes four major parks linked by a park drive, a world class urban trail system, and a remarkable water trail, all tracing Floyds Fork, a tributary of the Salt River. Due to the diverse topography of the area, 21st Century Parks needed a flexible retaining wall solution that would complement the natural aesthetic they were planning.

## THE SOLUTION

For a solution for the first phase of the project, which included both gravity

and reinforced Positive Connection (PC) System walls, the Parklands turned to Redi-Rock of Kentuckiana.

"It was chosen for a couple reasons," said Joe Daley, Architect and Project Manager for 21st Century Parks. "One, was the aesthetics: this is a park project, not a highway project. It had to fit in with the stone and other materials being used in the park. Also, the cost and the time frame were big considerations."

The next phase of the project included creating an overpass for Interstate 64. To keep the stone in place the project required a 1,200 square foot (111 square meter) gravity headwall.

"We went with Redi-Rock because of the footprint that was needed to

put the walls in," explained Burleigh Law, Senior Project Engineer with HNTB Corporation.

An additional phase of the Parklands project required three separate walls, totaling 21,000 square feet (1,950 square meters) of Redi-Rock to handle the significant grade changes on site. This phase included a 41 foot (12.5 meter) tall PC System wall that is the tallest Redi-Rock PC wall in the world to date, at the time of this printing.

"The high efficiency of the PC System really made it possible to design tiered walls with those loads at that height," said Design Engineer Clint Hines, PE. "It would be hard to make it work with anything else."



construction



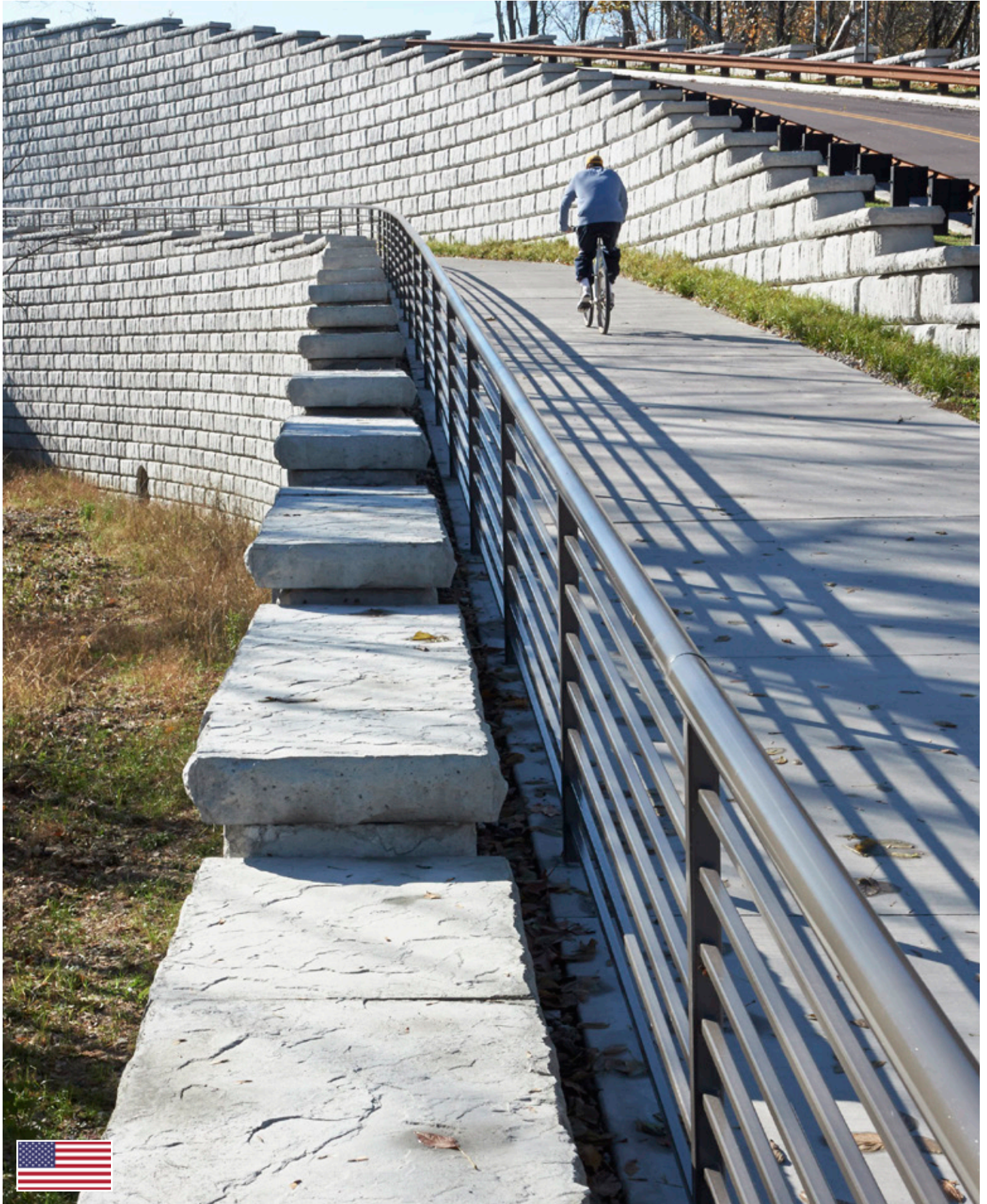

RESIDENTIAL/HIGHWAY APPLICATION:

# 12 Foot (3.6 Meter) Walls Install Quickly For Emergency Landslide Repair

## THE CHALLENGE

During a January 2012 storm consisting of heavy rain and ice, a water main in Bellevue, Washington broke—resulting in a significant landslide along a major highway. Faced with lane closures and damage to residential properties, the City needed a fast solution that would stabilize the slope and get traffic moving again.

“It basically washed the whole bank down into the houses and out on the beach. It was kind of an environmental disaster,” said Torger Erickson, PE and Project Manager for TetraTech.

## THE SOLUTION

The city of Bellevue had already been considering Redi-Rock as an option for 3–4 phases of planned

improvements along the highway prior to the landslide. When the slide happened, engineers and city officials were able to contact local Redi-Rock manufacturer Puget Sound Precast within 48 hours.

“Repairing the slope needed to happen quickly. These blocks solved the engineering problem, they had the aesthetics the homeowners wanted, and they were easy to install,” Erickson said.

“We didn’t have soil conditions that would allow us to drill tiebacks or lay geogrid. Other types of retaining walls higher than 6 foot (1.8 meter) require tie backs, but we were able to achieve a 12 foot (3.6 meter) tall wall by utilizing the weight of these blocks,” explained Bill Cross, Senior

Construction Inspector for the City.

The project required two separate walls; the lower wall was 9 feet (2.75 meters) tall with 3 feet (1 meter) of freestanding walls on top, and the upper wall was 12 feet (3.6 meters) tall. Both were built as gravity structures, creating tall walls that required no reinforcement.

“We built the walls in two stages; the lower wall took 4–5 days and the upper wall took 7–8 days,” said Doug Neal of Westwater Construction Inc. “The best thing about the system is that you don’t have to lay the blocks at a batter because it’s already built in. As a contractor, that makes a huge difference. You just build a level base and then pop the blocks in.”



before





RAIL APPLICATION:

# Back-to-Back Walls Support Freight Line

## THE CHALLENGE

In 2011, the Canadian National (CN) Railway and the Montreal Metro began construction to eliminate an at-grade crossing where the CN Rail line crossed over the Société de Transport de Montréal (STM) light commuter Metro line.

These two lines ran through a narrow corridor with several sections of track overlapping. To completely separate the tracks, plans were made to elevate the CN Rail line on a bridge structure and excavate to relocate the Metro underground. To elevate the CN Rail line, designers needed to build a gradual, walled slope leading up to a massive concrete bridge structure and then down the other side.

## THE SOLUTION

When CN Rail geotechnical engineers saw the Redi-Rock Positive Connection (PC) System at the Transportation Research Board (TRB) meeting in early 2011, they began incorporating Redi-Rock PC walls from local manufacturer Graymont Materials into the design.

David Chartier, junior engineer with V. Fournier & Associés, explained, “The PC System is the only block with this type of connection which allowed it to handle the loads. When you have massive loads so near the block facing, it’s hard to make a wall that will work. The walls are very high and the load is very close, but the civil engineering of this block made it a good fit.”

To install the geogrid for a PC System wall, a 12-inch (305 millimeter) wide strip of geogrid was wrapped through each retaining wall block, tying the Redi-Rock facing blocks to the reinforced soil mass with a weight-independent positive connection.

In total, the project required 7,800 Redi-Rock blocks— equaling 44,850 square feet (4,167 square meters). Trains made their first run on the line in late 2013, and the project has been performing exactly as engineered.



construction





STORM CHANNEL APPLICATION:

# Building A Stormwater Drainage System To Halt Creek Erosion

## THE CHALLENGE

Fred Creek is a storm water runoff channel in downtown Tulsa, near the campus of Oral Roberts University. When the natural banks of Fred Creek began eroding and threatening the stability of the banks and associated utilities, the City needed to stabilize the stream banks. The City also wanted to create an attractive green area for jogging trails and parks.

The goal of the renovation was to widen the banks of Fred Creek while following the existing channel as closely as possible in an effort to maintain a more natural look, as well as providing a more hospitable environment for wildlife and plants and a safer escape route.

## THE SOLUTION

“We have found in the past on similar projects that the smaller retaining wall blocks just won’t handle the velocity of the water,” said Bill Robinson PE, Project Manager and then-Senior Engineer in Stormwater Design for the city of Tulsa. “This is one of five projects that have either been done or are under construction in Tulsa right now using Redi-Rock or equal products.”

The first phase of this project involved 9-inch setback Redi-Rock retaining walls that stand 19 feet (5.8 meters) at the tallest point and encompass a total 68,000 square feet (6317 square meters). The project contains both gravity and reinforced walls that are placed atop a concrete footing and are buried five feet (1.5 meters) on

average. The walls are Limestone texture, with 15 percent of the face area composed of half-blocks to “break up” the look of the walls.

The second through sixth phases of the \$15.25 million Fred Creek Drainage Improvements project required extensive retaining walls, rip rap, landscaping, and new bridge construction.

Robinson, the Project Manager for the Fred Creek project, has since been promoted to Lead Engineer for Stormwater Planning for the City of Tulsa. He said the city will continue working with large block retaining walls for their erosion control needs throughout the city.





BRIDGE APPLICATION:

# Development Chooses Redi-Rock for Wing Walls and Amphitheater Construction

## THE CHALLENGE

When a \$300 million development was being built in Dartmouth, Nova Scotia, the roadway required three bridges to cross over Grassy Brook. The creek is a spawning site for trout and the bank hosts walking trails that are part of the trail system in Dartmouth.

## THE SOLUTION

Stantec Engineering designed the bridges using the BEBO arch system, which combines cast-in-place footings and precast concrete arches. After learning that Redi-Rock could provide zero-degree batter wing walls and headwalls to work in conjunction with the BEBO system, Stantec specified Redi-Rock for the job.

The bridge span pictured is 60 feet (18.25 meter) wide at the base and supports the roadway above while accommodating the stream below, as well as a walking trail next to the stream.

The wing walls and headwalls were constructed using Redi-Rock 28-inch (711-millimeter) geogrid-reinforced blocks with the Limestone texture. The local Redi-Rock manufacturer, DuraCast, produced custom Redi-Rock blocks to integrate with the BEBO arches. A crew of four to six from ACL Construction installed the blocks using a 20-ton Caterpillar excavator. To finish off the look of the bridge, Redi-Rock freestanding walls were installed, j-bolted in place, and capped. The freestanding walls also act as guardrails for the roadway.

Four years later, Dartmouth Crossing was ready to begin construction of Grassy Brook Park adjacent to the bridge. In homage to the trout spawning bed, the whole park area is designed in the outline of a fish. The focal point of Grassy Brook Park is the Pondsides Amphitheater, and the seating plan for the amphitheater needed to follow the curving design.

Because Redi-Rock allows both concave and convex curves to be built using the standard blocks, developers chose to use Redi-Rock for seating construction to tie the entire project together. In total, the amphitheater utilized 3,600 square feet (334 square meters) of Redi-Rock blocks.



construction







# BLOCK LIBRARY

# Three Custom Textures, One Complete System

Redi-Rock is a complete retaining wall solution that looks good. Engineers love it because it combines solid engineering and aesthetics, which can be a hard combination to find.

Redi-Rock offers three face textures: Ledgestone, Cobblestone, and Limestone. Any block in the Redi-Rock arsenal can be produced in any texture, which means that you can create a complete solution for your next project. Retaining wall blocks, freestanding blocks, and columns are available in each of the three textures, allowing you to design an integrated, coordinated project that looks awesome. Because Redi-Rock is made from first-use, architectural grade precast concrete, the detail in texture and the durability are phenomenal.

Each Redi-Rock block is cast in one continuous pour using molds taken from actual stone. These molds are bolt-on attachments to the Redi-Rock steel forms which can be interchanged from form to form. This means that a Redi-Rock manufacturer can use a single form to make a Ledgestone gravity block one day and a Limestone PC block the next day by simply switching out a few parts and pieces! This comprehensive forming system allows your local Redi-Rock manufacturer to create a variety of blocks, resulting in a faster, more affordable finished product.

Redi-Rock blocks are also available in a variety of color options to match the natural stone in your local area. Contact your local Redi-Rock manufacturer for color options!



Ledgestone



Cobblestone



Limestone



Ledgestone



Cobblestone



Limestone

REDI-ROCK TEXTURE:

# LEDGESTONE

When you need a structural retaining wall, but you also need a wall that blends with the natural stone in your area, LedgeStone is the right choice.

The LedgeStone face creates deep texture and gives walls a random, natural look. The texture on each block makes individual blocks nearly indistinguishable in a wall, giving the impression of a natural, random stone wall.

Redi-Rock LedgeStone is the perfect solution for projects that require both superior aesthetics and superior strength. Redi-Rock LedgeStone blocks are the same as Redi-Rock blocks you have worked with in the past—the same massive dimensions, wet-cast concrete quality, and ease of installation you’ve come to expect. Each block weighs one ton, and can

be used to create both tall gravity walls and even taller walls when utilizing reinforcement.

Local coloring options are available; contact your local manufacturer for more info!

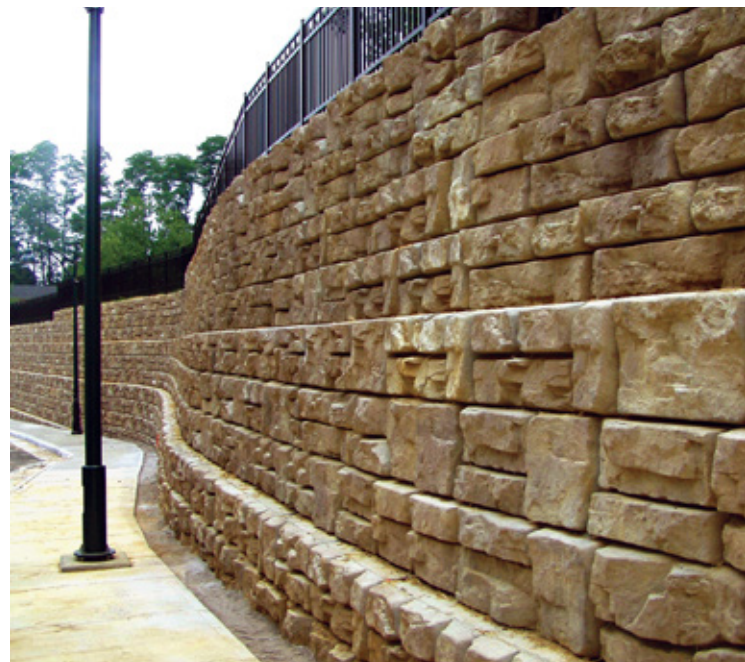



REDI-ROCK TEXTURE:

# COBBLESTONE

Large block retaining walls offer massive benefits, but what if you don't want a massive look in the finished wall? Now, you don't have to choose one or the other.

By choosing Redi-Rock Cobblestone texture, you'll get the best of both worlds—the structural capabilities of a large block retaining wall with a smaller-scale look. Each Cobblestone texture block has the

appearance of six smaller blocks on each face, and individual blocks are nearly indistinguishable in a finished wall. Each block is cast in a mold taken from real stone using wet-cast concrete—which gives walls a more natural finish while providing durability and strength.

Cobblestone blocks have the same massive dimensions, high quality, and ease of installation you expect

from Redi-Rock. Each block weighs one ton, allowing you to build tall gravity walls using Cobblestone blocks, and even taller walls with reinforcement.

Contact your local manufacturer for color options in you area!



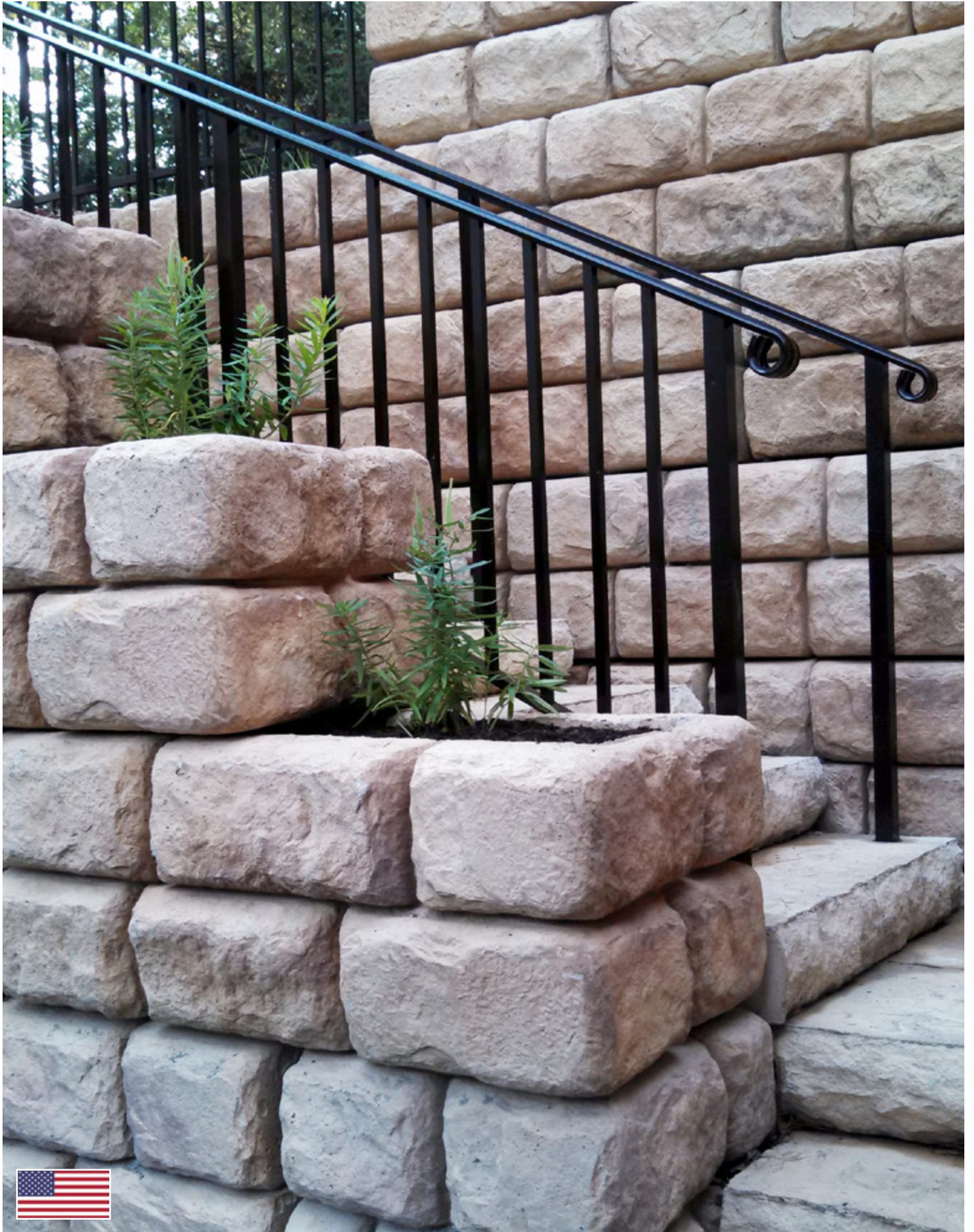

## REDI-ROCK TEXTURE: LIMESTONE

Redi-Rock Limestone texture creates an ideal look for projects that require a structural retaining wall that looks good. The massive, one-ton Limestone texture blocks feature six square feet (0.5 square meters) of face on each block, giving walls an impressive finished appearance.

Redi-Rock's Limestone face has been a mainstay in the large block

retaining wall industry since it was introduced. The texture on each block gives walls a natural look and is consistently chosen for projects where aesthetics are important. Redi-Rock is made of wet-cast concrete and the blocks are cast in molds taken from actual quarried limestone, providing more detailed texture, greater durability, and longer maintenance-free service life.

Redi-Rock Limestone blocks offer the massive dimensions, high quality, and ease of installation you've come to expect. At over one ton each, you can build tall gravity walls using Redi-Rock Limestone blocks, and even taller walls with reinforcement.

Contact your local manufacturer for color options!





## RETAINING BLOCKS (FINISHED TEXTURE ON ONE FACE)

The Redi-Rock Retaining wall blocks come in multiple widths and configurations. The defining characteristic is that Retaining blocks have an aesthetic texture cast into only ONE face, and the textured face is the only side exposed to view in the finished wall. These blocks are machine-placed, wet-cast, precast modular block units manufactured from first purpose, non-reconstituted concrete and intended for constructing dry-stacked modular retaining wall systems. The block units are manufactured from structural-grade concrete mixes in accordance with ASTM C94 or ASTM C685 that produce a finished unit with excellent resistance to freeze-thaw, deicing chemical exposure, and submerged conditions in both fresh water and salt water applications. All Redi-Rock blocks are manufactured and distributed through an international network of individually-owned, licensed precast concrete manufacturers.

### CONCRETE MIX PROPERTIES <sup>(1)</sup>

FREEZE THAW EXPOSURE CLASS <sup>(2)</sup>	MINIMUM 28 DAY COMPRESSIVE STRENGTH <sup>(3)</sup>	MAXIMUM WATER CEMENT RATIO	NOMINAL MAXIMUM AGGREGATE SIZE <sup>(10)</sup>	AGGREGATE CLASS DESIGNATION <sup>(4)</sup>	AIR CONTENT <sup>(5)</sup>
MODERATE	4,000 psi (27.6 MPa)	0.45	1.0 (25)	3M	4.5% ± 1.5%
SEVERE	4,000 psi (27.6 MPa)	0.45	1.0 (25)	3S	6.0% ± 1.5%
VERY SEVERE	4,500 psi (30.0 MPa)	0.40	1.0 (25)	4S	6.0% ± 1.5%
MAXIMUM WATER-SOLUBLE CHLORIDE ION (Cl <sup>-</sup> ) CONTENT IN CONCRETE, PERCENT BY WEIGHT OF CEMENT <sup>(6)</sup>					0.015
MAXIMUM CHLORIDE AS Cl <sup>-</sup> CONCENTRATION IN MIXING WATER, PARTS PER MILLION					1000
MAXIMUM PERCENTAGE OF TOTAL CEMENTITIOUS MATERIALS BY WEIGHT <sup>(7,9)</sup> (VERY SEVERE EXPOSURE CLASS ONLY)					
FLY ASH OR OTHER POZZOLANS PER ASTM C618		25	TOTAL ASH, POZZOLANS, SLAG, AND SILICA FUME <sup>(8)</sup>		50
SLAG CONFORMING TO ASTM C989		50	TOTAL ASH, POZZOLANS, AND SILICA FUME <sup>(8)</sup>		35
SILICA FUME CONFORMING TO ASTM C1240		10	ALKALI-AGGREGATE REACTIVITY MITIGATION PER ACI 201		

### REFERENCE DIMENSIONS:

HEIGHT = VERTICAL DIMENSION OF TEXTURED FACE  
 LENGTH = HORIZONTAL DIMENSION PARALLEL TO TEXTURED FACE  
 WIDTH = HORIZONTAL DIMENSION PERPENDICULAR TO TEXTURED FACE

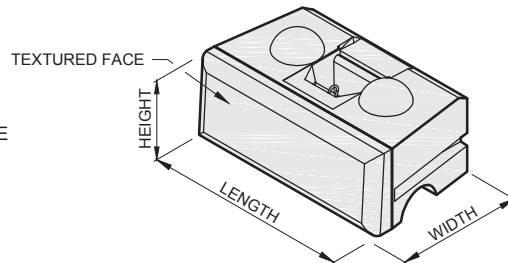

### DIMENSIONAL TOLERANCES <sup>(10) (11)</sup>

HEIGHT	ALL BLOCKS	18 ± 3/16 (457 ± 5)
LENGTH	FULL BLOCKS	46 1/8 ± 1/2 (1172 ± 13)
	HALF BLOCKS	22 13/16 ± 1/2 (579 ± 13)
WIDTH	28" (710) BLOCKS	22 5/8 ± 1/2 (575 ± 13) FORM LINE TO BACK OF BLOCK, PLUS APPROX. 5 3/8 (136) FACE TEXTURE
	41" (1030) BLOCKS	35 1/8 ± 1/2 (892 ± 13) FORM LINE TO BACK OF BLOCK, PLUS APPROXIMATELY 5 3/8 (136) FACE TEXTURE
	60" (1520) BLOCKS	54 5/8 ± 1/2 (1387 ± 13) FORM LINE TO BACK OF BLOCK, PLUS APPROXIMATELY 5 3/8 (136) FACE TEXTURE

<sup>(1)</sup> Concrete mix properties are in general accordance with ACI 318 durability requirements. Research has shown that concrete manufactured to these standards demonstrates good durability and performance. When these requirements are followed, specific freeze-thaw testing of the concrete is typically NOT required.

<sup>(2)</sup> Exposure class is as described in ACI 318.

<sup>(3)</sup> Test method ASTM C39.

<sup>(4)</sup> Defined in ASTM C33 Table 3 *Limits for Deleterious Substances and Physical Property Requirements of Coarse Aggregate for Concrete*.

<sup>(5)</sup> Test method ASTM C231.

<sup>(6)</sup> Test method ASTM C1218 at age between 28 and 42 days.

<sup>(7)</sup> The total cementitious material also includes ASTM C150, C595, C845, and C1157 cement. The maximum percentages shall include:

(a) Fly ash or other pozzolans in type IP, blended cement, ASTM C595, or ASTM C1157.

(b) Slag used in the manufacture of an IS blended cement, ASTM C595, or ASTM C1157.

(c) Silica fume, ASTM C1240, present in a blended cement.

<sup>(8)</sup> Fly ash or other pozzolans and silica fume shall constitute no more than 25 and 10 percent, respectively, of the total weight of the cementitious materials.

<sup>(9)</sup> Prescriptive limits shown may be waived for concrete mixes that demonstrate excellent freeze-thaw durability in a detailed and current testing program.

<sup>(10)</sup> All dimensions are shown in units of *inches (mm)*.

<sup>(11)</sup> Permissible defects: Chips smaller than 1.5" (38mm) in its largest dimension and cracks not wider than 0.012" (0.305mm) and not longer than 25% of the nominal height of the block; bug holes in the architectural face smaller than 0.75" (19mm); and bug holes, water marks, and color variation on non-architectural faces.

RETAINING BLOCKS

# Block Library

## 28" (710mm) TOP

Face Texture:	Cobble / Limestone	Ledgestone
Block Weight:	1229 lb (557 kg)	1158 lb (525 kg)
Block Volume:	8.57 ft <sup>3</sup> (0.243 m <sup>3</sup> )	8.07 ft <sup>3</sup> (0.229 m <sup>3</sup> )
Center of Gravity:	14.9" (378mm)	14.2" (362mm)

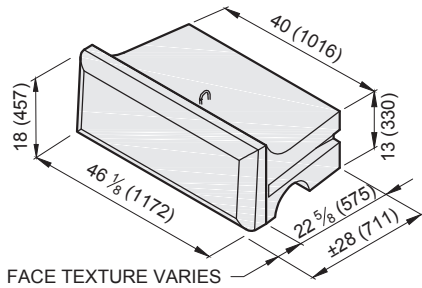

## 28" (710mm) HALF TOP

Face Texture:	Cobble / Limestone	Ledgestone
Block Weight:	573 lb (260 kg)	538 lb (244 kg)
Block Volume:	4.01 ft <sup>3</sup> (0.113 m <sup>3</sup> )	3.76 ft <sup>3</sup> (0.106 m <sup>3</sup> )
Center of Gravity:	15.3" (389 mm)	14.7" (373 mm)

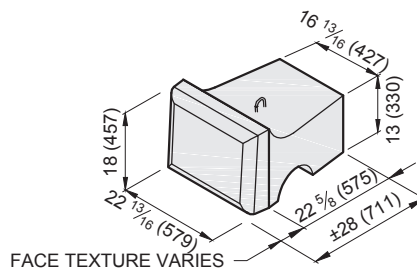

## 28" (710mm) MIDDLE

Face Texture:	Cobble / Limestone	Ledgestone
Block Weight:	1613 lb (732 kg)	1542 lb (699 kg)
Block Volume:	11.28 ft <sup>3</sup> (0.319 m <sup>3</sup> )	10.78 ft <sup>3</sup> (0.305 m <sup>3</sup> )
Center of Gravity:	13.9" (354 mm)	13.4" (340 mm)

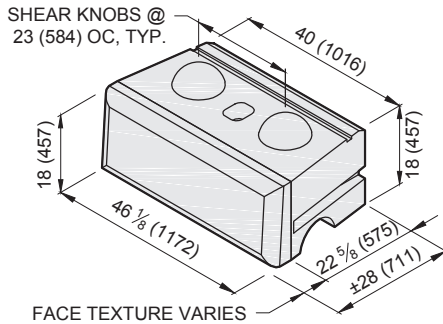

## 28" (710mm) HALF MIDDLE

Face Texture:	Cobble / Limestone	Ledgestone
Block Weight:	748 lb (339 kg)	713 lb (323 kg)
Block Volume:	5.23 ft <sup>3</sup> (0.148 m <sup>3</sup> )	4.98 ft <sup>3</sup> (0.141 m <sup>3</sup> )
Center of Gravity:	14.3" (364 mm)	13.8" (350 mm)

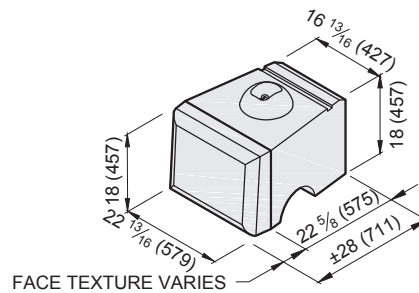

## 28" (710mm) BOTTOM

Face Texture:	Cobble / Limestone	Ledgestone
Block Weight:	1744 lb (791 kg)	1672 lb (758 kg)
Block Volume:	12.19 ft <sup>3</sup> (0.345 m <sup>3</sup> )	11.70 ft <sup>3</sup> (0.331 m <sup>3</sup> )
Center of Gravity:	14.0" (355 mm)	13.5" (343 mm)

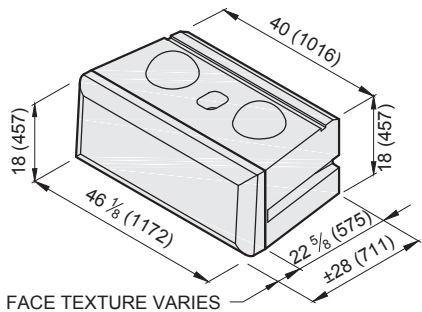

## 28" (710mm) HALF BOTTOM

Face Texture:	Cobble / Limestone	Ledgestone
Block Weight:	809 lb (367 kg)	774 lb (351 kg)
Block Volume:	5.66 ft <sup>3</sup> (0.160 m <sup>3</sup> )	5.41 ft <sup>3</sup> (0.153 m <sup>3</sup> )
Center of Gravity:	14.3" (364 mm)	13.8" (352 mm)

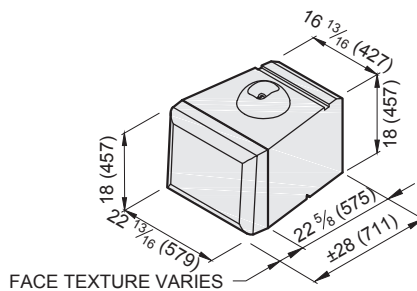

1. Units for dimensions are inches (mm), typical unless noted otherwise.
2. Confirm block production with licensed Redi-Rock manufacturer.
3. Center of Gravity is measured from the back of block.
4. Actual block volumes and weights may vary.
5. Weights are based upon a concrete density of 143 lb/ft<sup>3</sup> (2291kg/m<sup>3</sup>).

6. Half blocks contain a fork slot on only one side of the block.
7. Interface Shear knobs are typically 10" (254mm) diameter by 4" (102mm) tall. Smaller knob diameters are available.

RETAINING BLOCKS

# Block Library

## 41" (1030mm) TOP \*

Face Texture:	Cobble / Limestone	Ledgestone
Block Weight:	1748 lb (793 kg)	1677 lb (760 kg)
Block Volume:	12.22 ft <sup>3</sup> (0.346 m <sup>3</sup> )	11.73 ft <sup>3</sup> (0.332 m <sup>3</sup> )
Center of Gravity:	21.3" (540 mm)	20.6" (522 mm)

SPECIALITY BLOCK

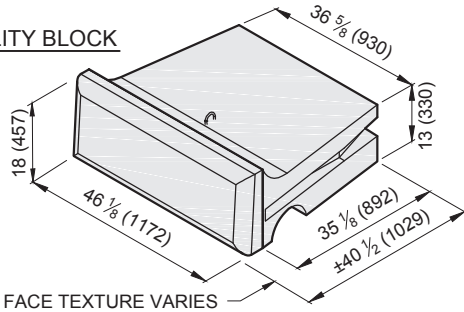

## 41" (1030mm) HALF TOP \*

Face Texture:	Cobble / Limestone	Ledgestone
Block Weight:	770 lb (350 kg)	735 lb (333 kg)
Block Volume:	5.38 ft <sup>3</sup> (0.15 m <sup>3</sup> )	5.14 ft <sup>3</sup> (0.15 m <sup>3</sup> )
Center of Gravity:	22.4" (568 mm)	21.6" (550 mm)

SPECIALITY BLOCK

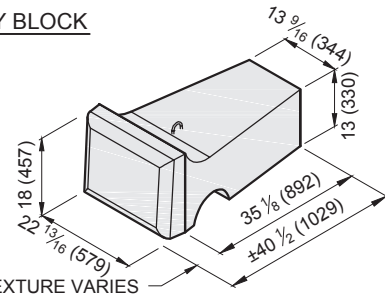

## 41" (1030mm) MIDDLE

Face Texture:	Cobble / Limestone	Ledgestone
Block Weight:	2309 lb (1047 kg)	2237 lb (1015 kg)
Block Volume:	16.14 ft <sup>3</sup> (0.457 m <sup>3</sup> )	15.65 ft <sup>3</sup> (0.443 m <sup>3</sup> )
Center of Gravity:	20.4" (518 mm)	19.8" (504 mm)

SHEAR KNOBS @ 23 (584) OC, TYP.

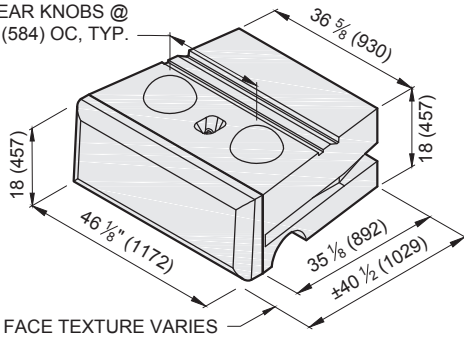

## 41" (1030mm) HALF MIDDLE

Face Texture:	Cobble / Limestone	Ledgestone
Block Weight:	1022 lb (463 kg)	987 lb (447 kg)
Block Volume:	7.14 ft <sup>3</sup> (0.20 m <sup>3</sup> )	6.90 ft <sup>3</sup> (0.20 m <sup>3</sup> )
Center of Gravity:	21.4" (543 mm)	20.8" (528 mm)

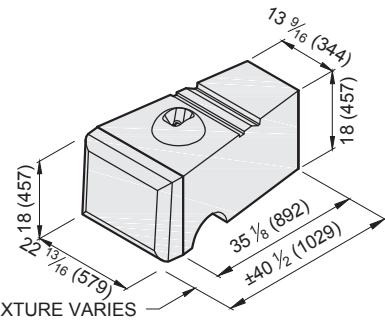

## 41" (1030mm) BOTTOM

Face Texture:	Cobble / Limestone	Ledgestone
Block Weight:	2439 lb (1106 kg)	2368 lb (1074 kg)
Block Volume:	17.06 ft <sup>3</sup> (0.483 m <sup>3</sup> )	16.56 ft <sup>3</sup> (0.469 m <sup>3</sup> )
Center of Gravity:	20.7" (527 mm)	20.2" (514 mm)

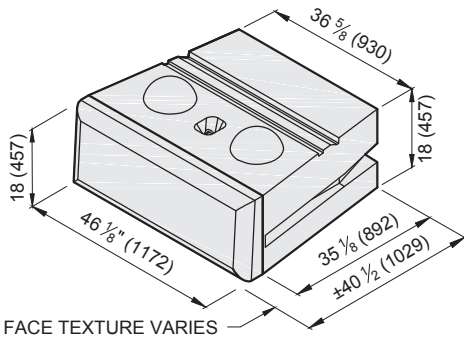

## 41" (1030mm) HALF BOTTOM

Face Texture:	Cobble / Limestone	Ledgestone
Block Weight:	1083 lb (491 kg)	1048 lb (475 kg)
Block Volume:	7.58 ft <sup>3</sup> (0.21 m <sup>3</sup> )	7.33 ft <sup>3</sup> (0.21 m <sup>3</sup> )
Center of Gravity:	21.7" (551 mm)	21.2" (538 mm)

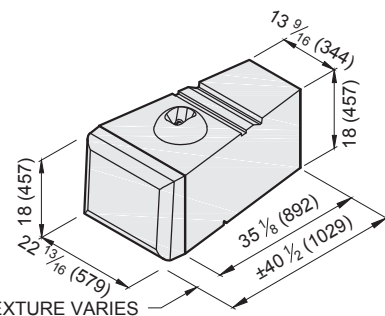

1. Units for dimensions are inches (mm), typical unless noted otherwise.
2. Confirm block production with licensed Redi-Rock manufacturer.
3. Center of Gravity is measured from the back of block.
4. Actual block volumes and weights may vary.
5. Weights are based upon a concrete density of 143 lb/ft<sup>3</sup> (2291kg/m<sup>3</sup>).

6. Half blocks contain a fork slot on only one side of the block.
7. Interface Shear knobs are typically 10" (254mm) diameter by 4" (102mm) tall. Smaller knob diameters are available.
8. \* 41" (1030mm) Top blocks are not typical and used in limited applications.

RETAINING BLOCKS

# Block Library

## 60" (1520mm) MIDDLE

Face Texture:	Cobble / Limestone	Ledgestone
Block Weight:	3287 lb (1491 kg)	3216 lb (1458 kg)
Block Volume:	23.00 ft <sup>3</sup> (0.651 m <sup>3</sup> )	22.49 ft <sup>3</sup> (0.637 m <sup>3</sup> )
Center of Gravity:	31.0" (786 mm)	30.4" (772 mm)

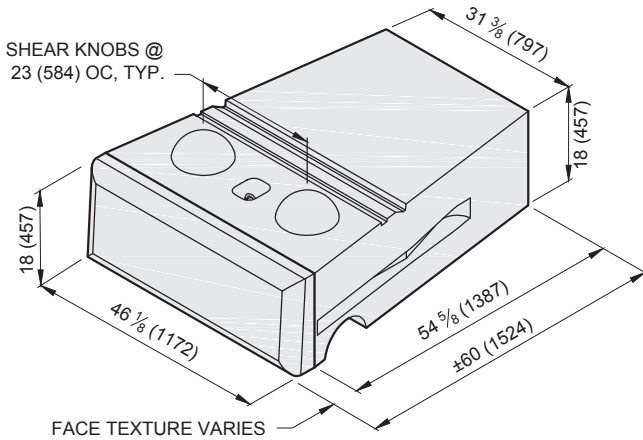

## 60" (1520mm) HALF MIDDLE

Face Texture:	Cobble / Limestone	Ledgestone
Block Weight:	1335 lb (606 kg)	1300 lb (590 kg)
Block Volume:	9.34 ft <sup>3</sup> (0.264 m <sup>3</sup> )	9.09 ft <sup>3</sup> (0.258 m <sup>3</sup> )
Center of Gravity:	33.7" (856 mm)	33.1" (840 mm)

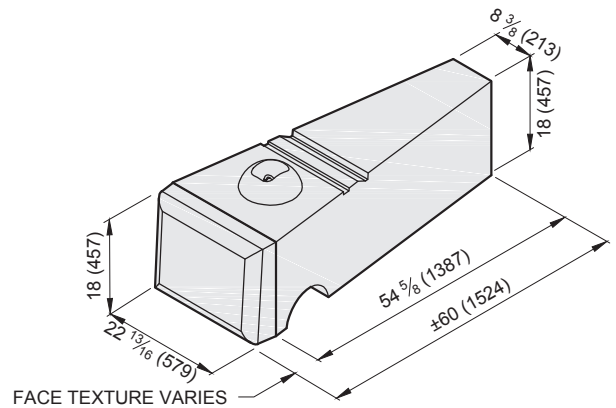

## 60" (1520mm) BOTTOM

Face Texture:	Cobble / Limestone	Ledgestone
Block Weight:	3418 lb (1550 kg)	3346 lb (1518 kg)
Block Volume:	23.90 ft <sup>3</sup> (0.677 m <sup>3</sup> )	23.40 ft <sup>3</sup> (0.663 m <sup>3</sup> )
Center of Gravity:	31.6" (802 mm)	31.0" (788 mm)

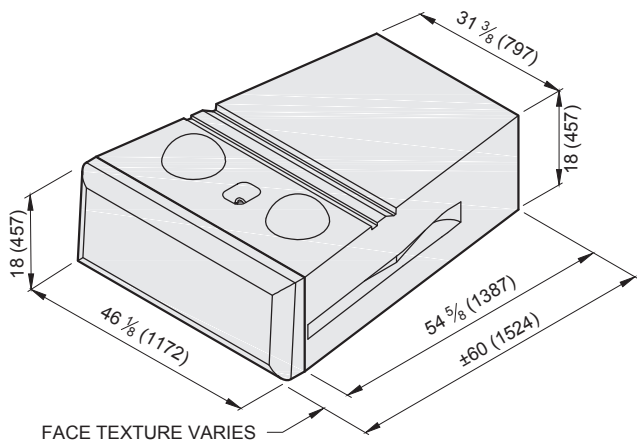

## 60" (1520mm) HALF BOTTOM

Face Texture:	Cobble / Limestone	Ledgestone
Block Weight:	1397 lb (633 kg)	1364 lb (618 kg)
Block Volume:	9.77 ft <sup>3</sup> (0.277 m <sup>3</sup> )	9.52 ft <sup>3</sup> (0.270 m <sup>3</sup> )
Center of Gravity:	34.3" (871 mm)	33.7" (856 mm)

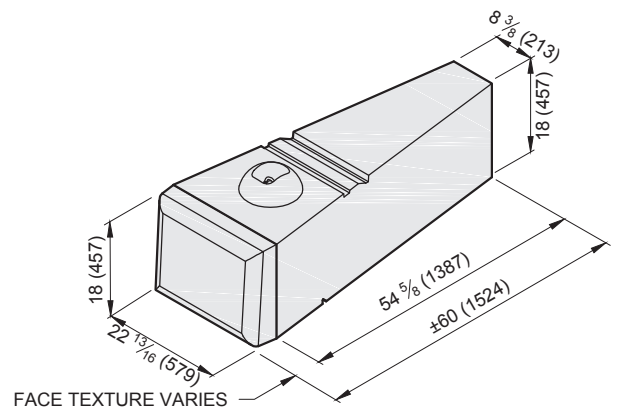

1. Units for dimensions are inches (mm), typical unless noted otherwise.
2. Confirm block production with licensed Redi-Rock manufacturer.
3. Center of Gravity is measured from the back of block.
4. Actual block volumes and weights may vary.
5. Weights are based upon a concrete density of 143 lb/ft<sup>3</sup> (2291kg/m<sup>3</sup>).

6. 60" (1520 mm) are typically used at the bottom of taller walls.
7. Half blocks contain a fork slot on only one side of the block.
8. Interface Shear knobs are typically 10" (254mm) diameter by 4" (102mm) tall. Smaller knob diameters are available.

RETAINING BLOCKS

# Block Library

## 41" (1030mm) MIDDLE 9" (230mm) SETBACK

Face Texture:	Cobble / Limestone	Ledgestone	Face Texture:	Cobble / Limestone	Ledgestone
Block Weight:	2319 lb (1052 kg)	2247 lb (1019 kg)	Block Weight:	1030 lb (467 kg)	995 lb (451 kg)
Block Volume:	16.21 ft <sup>3</sup> (0.46 m <sup>3</sup> )	15.72 ft <sup>3</sup> (0.44 m <sup>3</sup> )	Block Volume:	7.20 ft <sup>3</sup> (0.20 m <sup>3</sup> )	6.96 ft <sup>3</sup> (0.20 m <sup>3</sup> )
Center of Gravity:	20.2" (514 mm)	19.7" (500 mm)	Center of Gravity:	21.3" (540 mm)	20.7" (525 mm)

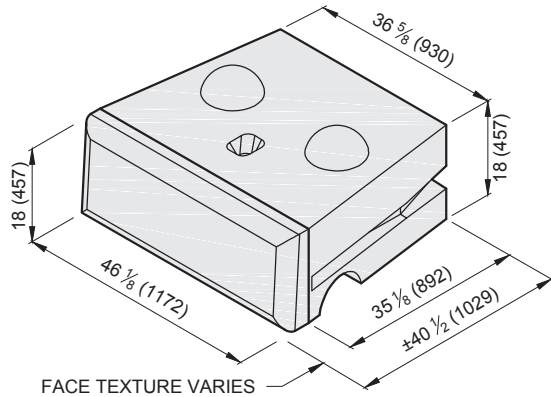

**FULL MIDDLE**

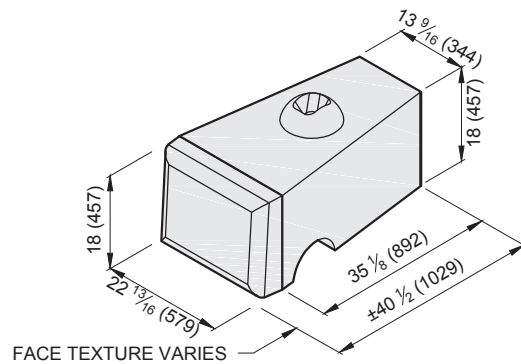

**HALF MIDDLE**

## 41" (1030mm) BOTTOM 9" (230mm) SETBACK

Face Texture:	Cobble / Limestone	Ledgestone	Face Texture:	Cobble / Limestone	Ledgestone
Block Weight:	2449 lb (1111 kg)	2378 lb (1078 kg)	Block Weight:	1092 lb (495 kg)	1057 lb (479 kg)
Block Volume:	17.13 ft <sup>3</sup> (0.48 m <sup>3</sup> )	16.63 ft <sup>3</sup> (0.47 m <sup>3</sup> )	Block Volume:	7.63 ft <sup>3</sup> (0.22 m <sup>3</sup> )	7.39 ft <sup>3</sup> (0.21 m <sup>3</sup> )
Center of Gravity:	20.6" (523 mm)	20.1" (510 mm)	Center of Gravity:	21.6" (548 mm)	21.0" (534 mm)

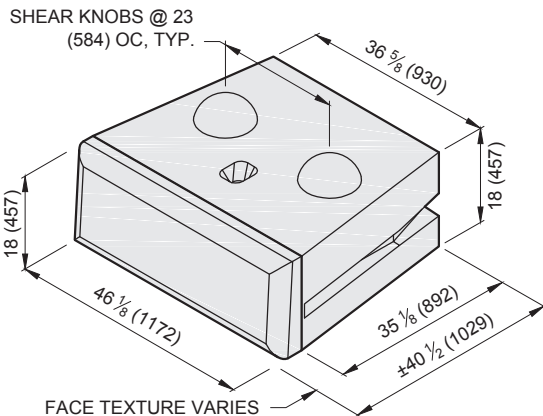

**FULL BOTTOM**

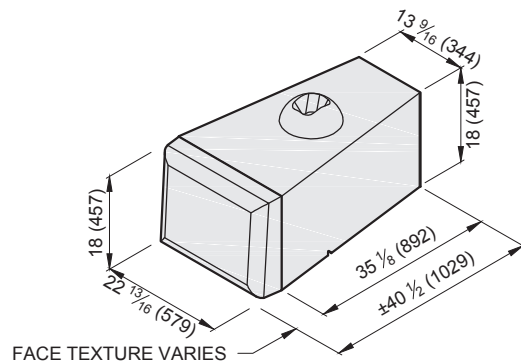

**HALF BOTTOM**

- Units for dimensions are inches (mm), typical unless noted otherwise.
- Confirm block production with licensed Redi-Rock manufacturer.
- Center of Gravity is measured from the back of block.
- Actual block volumes and weights may vary.
- Weights are based upon a concrete density of 143 lb/ft<sup>3</sup> (2291kg/m<sup>3</sup>).
- Half blocks contain a fork slot on only one side of the block.
- Interface Shear knobs are typically 10" (254mm) diameter by 4" (102 mm) tall.

RETAINING BLOCKS

# Block Library

## 60" (1520mm) MIDDLE 9" (230mm) SETBACK

Face Texture:	Cobble / Limestone	Ledgestone	Face Texture:	Cobble / Limestone	Ledgestone
Block Weight:	3297 lb (1495 kg)	3226 lb (1463 kg)	Block Weight:	1340 lb (608 kg)	1305 lb (592 kg)
Block Volume:	23.06 ft <sup>3</sup> (0.65 m <sup>3</sup> )	22.56 ft <sup>3</sup> (0.64 m <sup>3</sup> )	Block Volume:	9.37 ft <sup>3</sup> (0.26 m <sup>3</sup> )	9.12 ft <sup>3</sup> (0.26 m <sup>3</sup> )
Center of Gravity:	30.9" (785 mm)	30.3" (770 mm)	Center of Gravity:	33.6" (855 mm)	33.0" (839 mm)

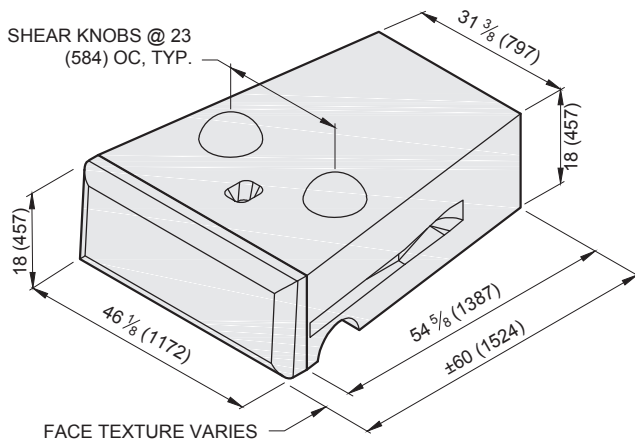

**FULL MIDDLE**

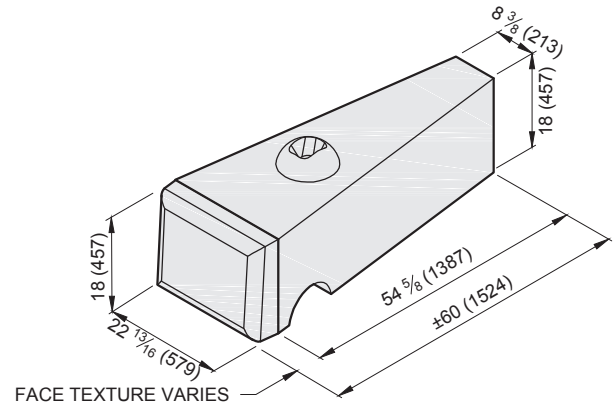

**HALF MIDDLE**

## 60" (1520mm) BOTTOM 9" (230mm) SETBACK

Face Texture:	Cobble / Limestone	Ledgestone	Face Texture:	Cobble / Limestone	Ledgestone
Block Weight:	3428 lb (1554 kg)	3356 lb (1522 kg)	Block Weight:	1401 lb (635 kg)	1366 lb (620 kg)
Block Volume:	23.97 ft <sup>3</sup> (0.68 m <sup>3</sup> )	23.47 ft <sup>3</sup> (0.66 m <sup>3</sup> )	Block Volume:	9.80 ft <sup>3</sup> (0.28 m <sup>3</sup> )	9.55 ft <sup>3</sup> (0.27 m <sup>3</sup> )
Center of Gravity:	31.5" (800 mm)	30.9" (786 mm)	Center of Gravity:	34.2" (869 mm)	33.6" (854 mm)

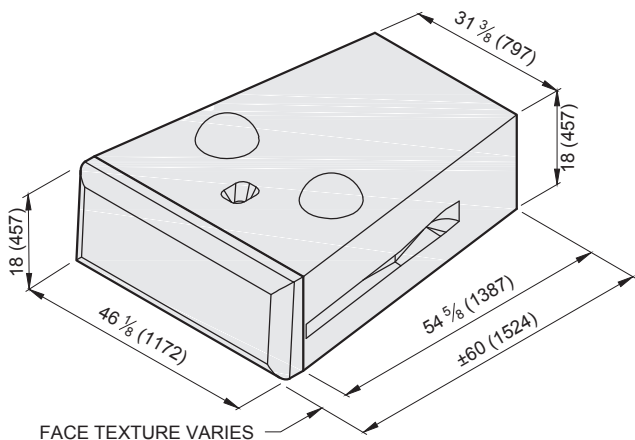

**FULL BOTTOM**

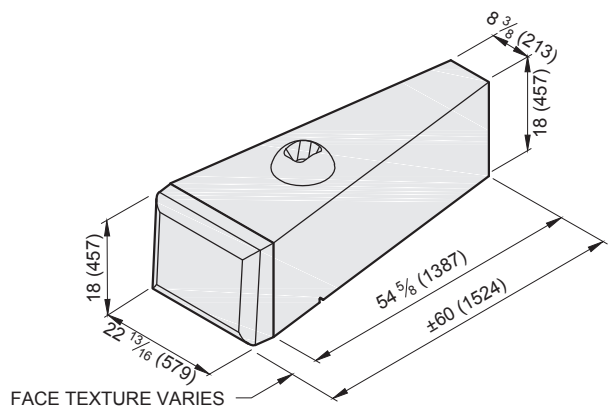

**HALF BOTTOM**

1. Units for dimensions are inches (mm), typical unless noted otherwise.
2. Confirm block production with licensed Redi-Rock manufacturer.
3. Center of Gravity is measured from the back of block.
4. Actual block volumes and weights may vary.
5. Weights are based upon a concrete density of 143 lb/ft<sup>3</sup> (2291kg/m<sup>3</sup>).
6. Half blocks contain a fork slot on only one side of the block.
7. Interface Shear knobs are typically 10" (254mm) diameter by 4" (102 mm) tall.
8. 60" (1520 mm) Blocks are typically used at the bottom of taller walls.

RETAINING BLOCKS

# Block Library

## 28" (710mm) PC TOP

Face Texture:	Cobble / Limestone	Ledgestone
Block Weight:	1167 lb (529 kg)	1096 lb (497 kg)
Block Volume:	8.16 ft <sup>3</sup> (0.231 m <sup>3</sup> )	7.66 ft <sup>3</sup> (0.217 m <sup>3</sup> )
Center of Gravity:	15.3" (388 mm)	14.6" (372 mm)

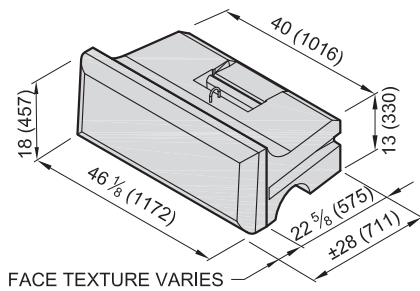

## 41" (1030mm) PC TOP

Face Texture:	Cobble / Limestone	Ledgestone
Block Weight:	1627 lb (738 kg)	1556 lb (706 kg)
Block Volume:	11.38 ft <sup>3</sup> (0.32 m <sup>3</sup> )	10.88 ft <sup>3</sup> (0.31 m <sup>3</sup> )
Center of Gravity:	21.8" (554 mm)	21.1" (536 mm)

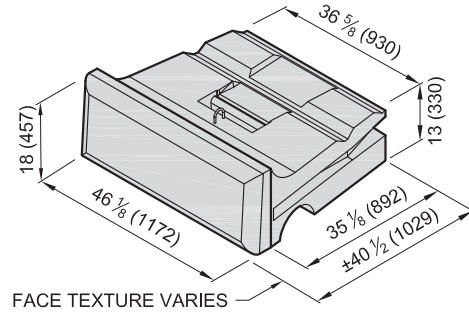

## 28" (710mm) PC MIDDLE

Face Texture:	Cobble / Limestone	Ledgestone
Block Weight:	1518 lb (689 kg)	1447 lb (656 kg)
Block Volume:	10.62 ft <sup>3</sup> (0.301 m <sup>3</sup> )	10.12 ft <sup>3</sup> (0.287 m <sup>3</sup> )
Center of Gravity:	14.2" (360 mm)	13.6" (346 mm)

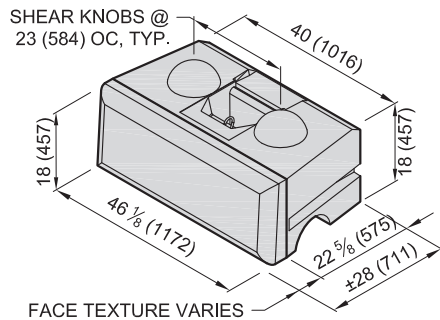

## 41" (1030mm) PC MIDDLE

Face Texture:	Cobble / Limestone	Ledgestone
Block Weight:	2172 lb (985 kg)	2101 lb (953 kg)
Block Volume:	15.2 ft <sup>3</sup> (0.43 m <sup>3</sup> )	14.69 ft <sup>3</sup> (0.42 m <sup>3</sup> )
Center of Gravity:	20.6" (522 mm)	20.0" (508 mm)

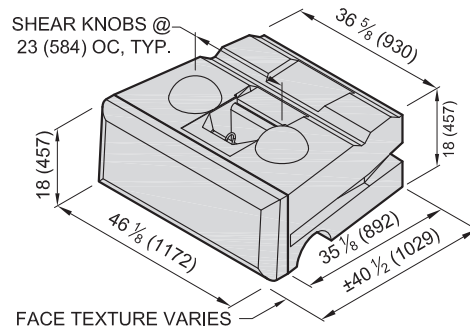

## 28" (710mm) PC BOTTOM

Face Texture:	Cobble / Limestone	Ledgestone
Block Weight:	1622 lb (736 kg)	1551 lb (703 kg)
Block Volume:	11.34 ft <sup>3</sup> (0.321 m <sup>3</sup> )	10.85 ft <sup>3</sup> (0.307 m <sup>3</sup> )
Center of Gravity:	14.2" (362 mm)	13.7" (349 mm)

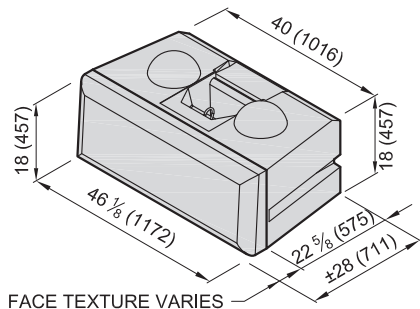

## 41" (1030mm) PC BOTTOM

Face Texture:	Cobble / Limestone	Ledgestone
Block Weight:	2276 lb (1032 kg)	2205 lb (1000 kg)
Block Volume:	15.92 ft <sup>3</sup> (0.45 m <sup>3</sup> )	15.42 ft <sup>3</sup> (0.44 m <sup>3</sup> )
Center of Gravity:	20.2" (514mm)	19.7" (501mm)

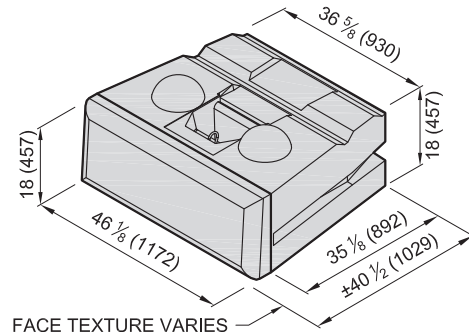

1. Units for dimensions are inches (mm), typical unless noted otherwise.
2. Confirm block production with licensed Redi-Rock manufacturer.
3. Center of Gravity is measured from the back of block.
4. Actual block volumes and weights may vary.
5. Weights are based upon a concrete density of 143 lb/ft<sup>3</sup> (2291kg/m<sup>3</sup>).

6. Blocks contain a vertical slot for a 12" (300 mm) strip of geogrid soil reinforcement.
7. Interface Shear knobs are typically 10" (254mm) diameter by 4" (102 mm) tall. Smaller knob diameters are available.

RETAINING BLOCKS

# Block Library

## 41" (1030mm) PLANTER

Face Texture:	Cobble / Limestone	Ledgestone
Block Weight:	2005 lb (910 kg)	1934 lb (877 kg)
Block Volume:	14.02 ft <sup>3</sup> (0.40 m <sup>3</sup> )	13.53 ft <sup>3</sup> (0.38 m <sup>3</sup> )
Center of Gravity:	19.1" (485 mm)	18.4" (468 mm)

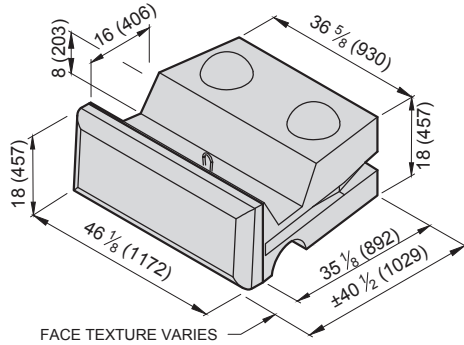

## 41" (1030mm) HALF PLANTER

Face Texture:	Cobble / Limestone	Ledgestone
Block Weight:	878 lb (398 kg)	843 lb (382 kg)
Block Volume:	6.14 ft <sup>3</sup> (0.17 m <sup>3</sup> )	5.89 ft <sup>3</sup> (0.17 m <sup>3</sup> )
Center of Gravity:	20.2" (513 mm)	19.5" (495 mm)

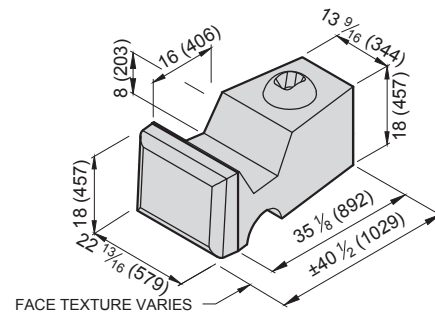

## MODIFIED TOP

Face Texture:	Cobble / Limestone	Ledgestone
Block Weight:	1198 lb (543 kg)	1127 lb (511 kg)
Block Volume:	8.38 ft <sup>3</sup> (0.24 m <sup>3</sup> )	7.88 ft <sup>3</sup> (0.22 m <sup>3</sup> )
Center of Gravity:	17.9" (455 mm)	17.2" (438 mm)

## MODIFIED HALF TOP

Face Texture:	Cobble / Limestone	Ledgestone
Block Weight:	708 lb (321 kg)	637 lb (289 kg)
Block Volume:	4.95 ft <sup>3</sup> (0.14 m <sup>3</sup> )	4.45 ft <sup>3</sup> (0.13 m <sup>3</sup> )
Center of Gravity:	20.7" (527 mm)	19.8" (504 mm)

### SPECIALITY BLOCK

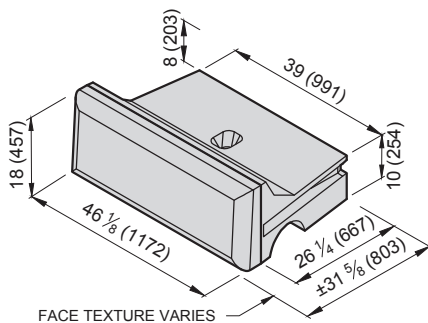

### SPECIALITY BLOCK

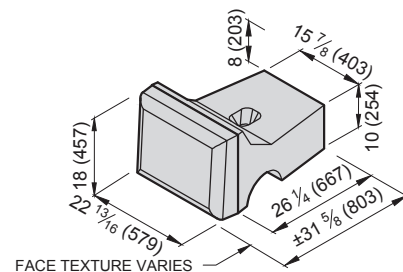

1. Units for dimensions are inches (mm), typical unless noted otherwise.
2. Confirm block production with licensed Redi-Rock manufacturer.
3. Center of Gravity is measured from the back of block.
4. Actual block volumes and weights may vary.
5. Weights are based upon a concrete density of 143 lb/ft<sup>3</sup> (2291kg/m<sup>3</sup>).

6. Half blocks contain a fork slot on only one side of the block.
7. Interface Shear knobs are typically 10" (254 mm) diameter by 4" (102 mm) tall.

RETAINING BLOCKS

# Block Library

## BOTTOM ANCHOR

Face Texture:	Cobble / Limestone	Ledgestone
Block Weight:	2365 lb (1073 kg)	2294 lb (1040 kg)
Block Volume:	16.54 ft <sup>3</sup> (0.47 m <sup>3</sup> )	16.04 ft <sup>3</sup> (0.45 m <sup>3</sup> )
Center of Gravity:	21.0" (533 mm)	20.4" (519 mm)

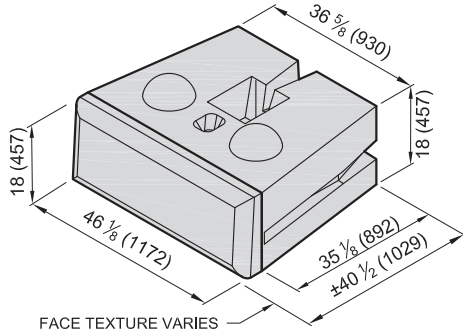

## MIDDLE ANCHOR

Face Texture:	Cobble / Limestone	Ledgestone
Block Weight:	2235 lb (1014 kg)	2164 lb (981 kg)
Block Volume:	15.63 ft <sup>3</sup> (0.44 m <sup>3</sup> )	15.13 ft <sup>3</sup> (0.43 m <sup>3</sup> )
Center of Gravity:	20.6" (523 mm)	20.0" (509 mm)

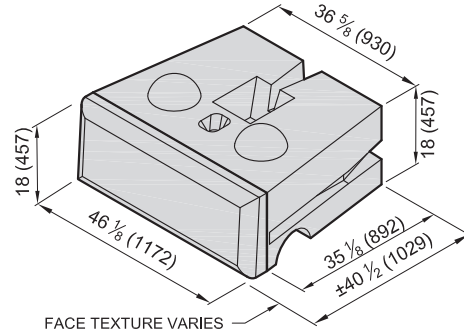

## SHORT MIDDLE

Face Texture:	Cobble / Limestone	Ledgestone
Block Weight:	2137 lb (969 kg)	2075 lb (941 kg)
Block Volume:	14.95 ft <sup>3</sup> (0.42 m <sup>3</sup> )	14.51 ft <sup>3</sup> (0.41 m <sup>3</sup> )
Center of Gravity:	19.7" (499mm)	19.2" (487mm)

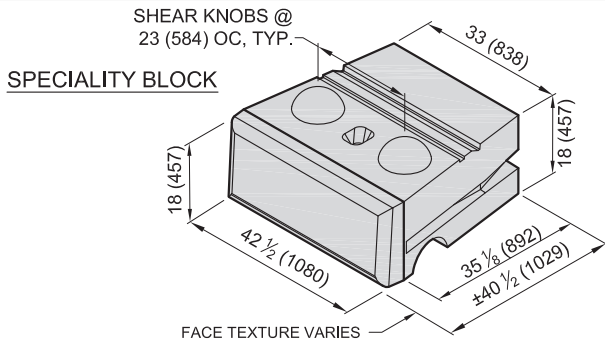

## SHORT TOP

Face Texture:	Cobble / Limestone	Ledgestone
Block Weight:	1111 lb (504 kg)	1048 lb (475 kg)
Block Volume:	7.77 ft <sup>3</sup> (0.22 m <sup>3</sup> )	7.33 ft <sup>3</sup> (0.21 m <sup>3</sup> )
Center of Gravity:	13.7" (349mm)	13.2" (336mm)

**SPECIALITY BLOCK**

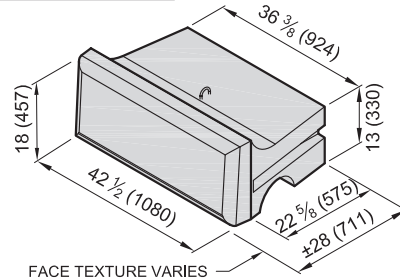

## 9" (230mm) SETBACK SHORT MIDDLE

Face Texture:	Cobble / Limestone	Ledgestone
Block Weight:	1281 lb (581 kg)	1239 lb (562 kg)
Block Volume:	8.96 ft <sup>3</sup> (0.25 m <sup>3</sup> )	8.66 ft <sup>3</sup> (0.24 m <sup>3</sup> )
Center of Gravity:	20.0" (507mm)	19.5" (494mm)

**SPECIALITY BLOCK**

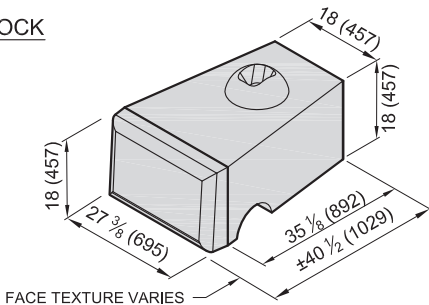

## 9" (230mm) SETBACK SHORT TOP

Face Texture:	Cobble / Limestone	Ledgestone
Block Weight:	706 lb (320 kg)	664 lb (301 kg)
Block Volume:	4.94 ft <sup>3</sup> (0.14 m <sup>3</sup> )	4.64 ft <sup>3</sup> (0.13 m <sup>3</sup> )
Center of Gravity:	13.9" (352mm)	13.3" (339mm)

**SPECIALITY BLOCK**

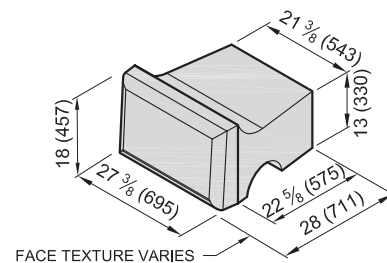

1. Units for dimensions are inches (mm), typical unless noted otherwise.
2. Confirm block production with licensed Redi-Rock manufacturer.
3. Center of Gravity is measured from the back of block.
4. Actual block volumes and weights may vary.
5. Weights are based upon a concrete density of 143 lb/ft<sup>3</sup> (2291kg/m<sup>3</sup>).

6. 27" (695) wide blocks contain a fork slot on only one side of the block. These are speciality blocks and may have limited availability and is only used in double 90 degree corner applications.
7. Interface Shear knobs are typically 10" (254mm) diameter by 4" (102 mm) tall. Smaller knob diameters are available.



## FREESTANDING BLOCKS (FINISHED TEXTURE ON MORE THAN ONE FACE)

The Redi-Rock Freestanding blocks come in one width and stack in a vertical manner. The defining characteristic is that freestanding blocks have an aesthetic texture cast into multiple faces; the textured face is on at least the two longitudinal vertical faces, and also as required on one end or the top of the blocks. These blocks are machine-placed, wet-cast, precast modular block units manufactured from first purpose, non-reconstituted concrete and intended for constructing dry-stacked modular retaining wall systems. The block units are manufactured from structural-grade concrete mixes in accordance with ASTM C94 or ASTM C685 that produce a finished unit with excellent resistance to freeze-thaw, deicing chemical exposure, and submerged conditions in both fresh water and salt water applications. All Redi-Rock blocks are manufactured and distributed through an international network of individually-owned, licensed precast concrete manufacturers.

### CONCRETE MIX PROPERTIES <sup>(1)</sup>

FREEZE THAW EXPOSURE CLASS <sup>(2)</sup>	MINIMUM 28 DAY COMPRESSIVE STRENGTH <sup>(3)</sup>	MAXIMUM WATER CEMENT RATIO	NOMINAL MAXIMUM AGGREGATE SIZE <sup>(10)</sup>	AGGREGATE CLASS DESIGNATION <sup>(4)</sup>	AIR CONTENT <sup>(5)</sup>
MODERATE	4,000 psi (27.6 MPa)	0.45	1.0 (25)	3M	4.5% ± 1.5%
SEVERE	4,000 psi (27.6 MPa)	0.45	1.0 (25)	3S	6.0% ± 1.5%
VERY SEVERE	4,500 psi (30.0 MPa)	0.40	1.0 (25)	4S	6.0% ± 1.5%
MAXIMUM WATER-SOLUBLE CHLORIDE ION (Cl <sup>-</sup> ) CONTENT IN CONCRETE, PERCENT BY WEIGHT OF CEMENT <sup>(6)</sup>					0.015
MAXIMUM CHLORIDE AS Cl <sup>-</sup> CONCENTRATION IN MIXING WATER, PARTS PER MILLION					1000
MAXIMUM PERCENTAGE OF TOTAL CEMENTITIOUS MATERIALS BY WEIGHT <sup>(7, 9)</sup> (VERY SEVERE EXPOSURE CLASS ONLY)					
FLY ASH OR OTHER POZZOLANS PER ASTM C618		25	TOTAL ASH, POZZOLANS, SLAG, AND SILICA FUME <sup>(8)</sup>		50
SLAG CONFORMING TO ASTM C989		50	TOTAL ASH, POZZOLANS, AND SILICA FUME <sup>(8)</sup>		35
SILICA FUME CONFORMING TO ASTM C1240		10	ALKALI-AGGREGATE REACTIVITY MITIGATION PER ACI 201		

### REFERENCE DIMENSIONS:

HEIGHT = VERTICAL DIMENSION OF TEXTURED FACE  
 LENGTH = LONGER HORIZONTAL DIMENSION PARALLEL TO TEXTURED FACES  
 WIDTH = HORIZONTAL DIMENSION PERPENDICULAR TO LONGER TEXTURED FACES

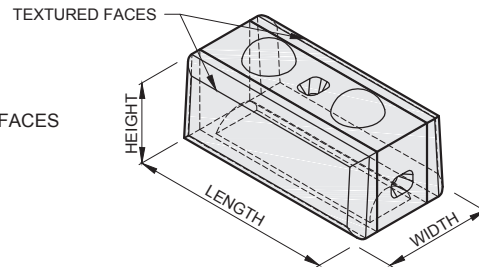

### DIMENSIONAL TOLERANCES <sup>(10) (11)</sup>

HEIGHT	ALL BLOCKS	18 ± 3/16 (457 ± 5)
LENGTH	FULL BLOCKS	46 1/8 ± 1/2 (1172 ± 13)
	HALF BLOCKS	22 13/16 ± 1/2 (579 ± 13)
WIDTH	23 -24 (584-610)	13 ± 1/2 (330 ± 13) FORM LINE TO FORM LINE, PLUS APPROX. 5 3/8 (136) FACE TEXTURE ON LONG SIDES

- <sup>(1)</sup> Concrete mix properties are in general accordance with ACI 318 durability requirements. Research has shown that concrete manufactured to these standards demonstrates good durability and performance. When these requirements are followed, specific freeze-thaw testing of the concrete is typically NOT required.
- <sup>(2)</sup> Exposure class is as described in ACI 318.
- <sup>(3)</sup> Test method ASTM C39.
- <sup>(4)</sup> Defined in ASTM C33 Table 3 *Limits for Deleterious Substances and Physical Property Requirements of Coarse Aggregate for Concrete*.
- <sup>(5)</sup> Test method ASTM C231.
- <sup>(6)</sup> Test method ASTM C1218 at age between 28 and 42 days.
- <sup>(7)</sup> The total cementitious material also includes ASTM C150, C595, C845, and C1157 cement. The maximum percentages shall include:
  - (a) Fly ash or other pozzolans in type IP, blended cement, ASTM C595, or ASTM C1157.
  - (b) Slag used in the manufacture of an IS blended cement, ASTM C595, or ASTM C1157.
  - (c) Silica fume, ASTM C1240, present in a blended cement.
- <sup>(8)</sup> Fly ash or other pozzolans and silica fume shall constitute no more than 25 and 10 percent, respectively, of the total weight of the cementitious materials.
- <sup>(9)</sup> Prescriptive limits shown may be waived for concrete mixes that demonstrate excellent freeze-thaw durability in a detailed and current testing program.
- <sup>(10)</sup> All dimensions are shown in units of *inches (mm)*.
- <sup>(11)</sup> Permissible defects: Chips smaller than 1.5 (38) in its largest dimension and cracks not wider than 0.012 (0.305) and not longer than 25% of the nominal height of the block; bug holes in the architectural face smaller than 0.75 (19); and bug holes, water marks, and color variation on non-architectural faces.

FREESTANDING BLOCKS

# Block Library

## STRAIGHT MIDDLE

Face Texture:	Cobble / Limestone	Ledgestone
Block Weight:	1407 lb (638 kg)	1264 lb (573 kg)
Block Volume:	9.84 ft <sup>3</sup> (0.279 m <sup>3</sup> )	8.84 ft <sup>3</sup> (0.250 m <sup>3</sup> )

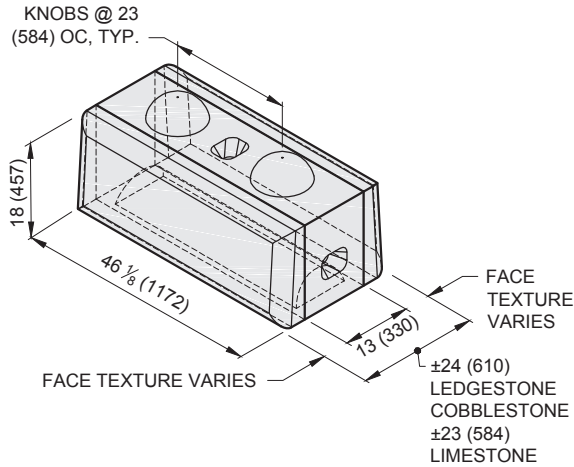

## STRAIGHT GARDEN TOP

Face Texture:	Cobble / Limestone	Ledgestone
Block Weight:	1050 lb (476 kg)	908 lb (412 kg)
Block Volume:	7.35 ft <sup>3</sup> (0.208 m <sup>3</sup> )	6.35 ft <sup>3</sup> (0.180 m <sup>3</sup> )

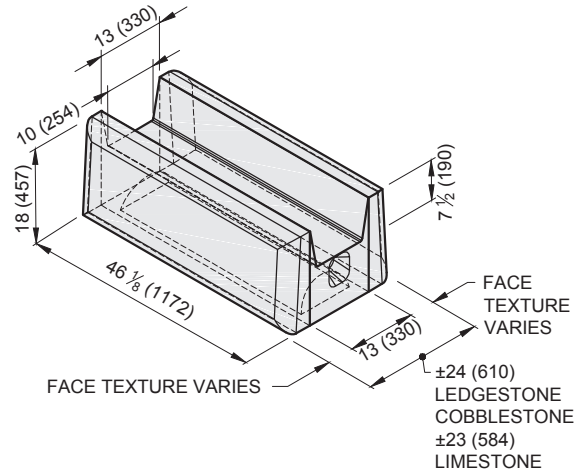

## STRAIGHT BOTTOM

Face Texture:	Cobble / Limestone	Ledgestone
Block Weight:	1523 lb (691 kg)	1381 lb (626 kg)
Block Volume:	10.65 ft <sup>3</sup> (0.302 m <sup>3</sup> )	9.66 ft <sup>3</sup> (0.273 m <sup>3</sup> )

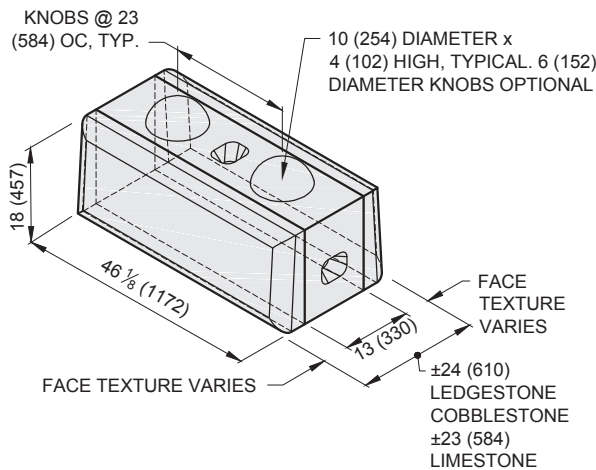

## STRAIGHT TOP

Face Texture:	Cobble / Limestone	Ledgestone
Block Weight:	1375 lb (623 kg)	1232 lb (559 kg)
Block Volume:	9.61 ft <sup>3</sup> (0.272 m <sup>3</sup> )	8.62 ft <sup>3</sup> (0.244 m <sup>3</sup> )

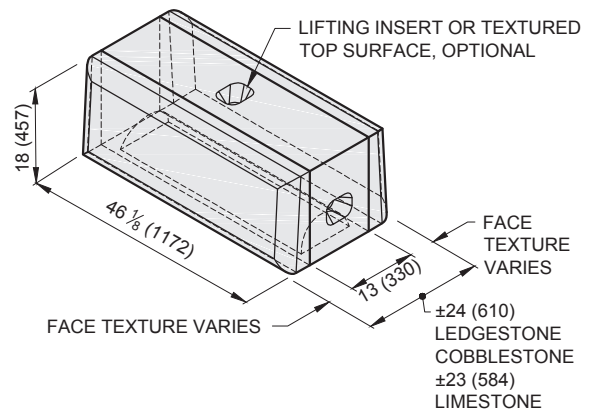

1. Units for dimensions are inches (mm), typical unless noted otherwise.
2. Confirm block production with licensed Redi-Rock manufacturer.
3. Architectural faces on the blocks have varying texture.
4. Actual block volumes and weights may vary.
5. Weights are based upon a concrete density of 143 lb/ft<sup>3</sup> (2291 kg/m<sup>3</sup>).

6. 6" (152 mm) diameter vertical semi-cylindrical voids at the ends of the block for mechanical tie-down are available, refer to Force Protection blocks for additional information.
7. Knobs are typically 10" (254mm) diameter by 4" (102 mm) tall. Smaller knobs are available.

FREESTANDING BLOCKS

# Block Library

## VARIABLE RADIUS MIDDLE

Face Texture:	Cobble / Limestone	Ledgestone
Block Weight:	1267 lb (574 kg)	1124 lb (510 kg)
Block Volume:	8.86 ft <sup>3</sup> (0.251 m <sup>3</sup> )	7.86 ft <sup>3</sup> (0.223 m <sup>3</sup> )

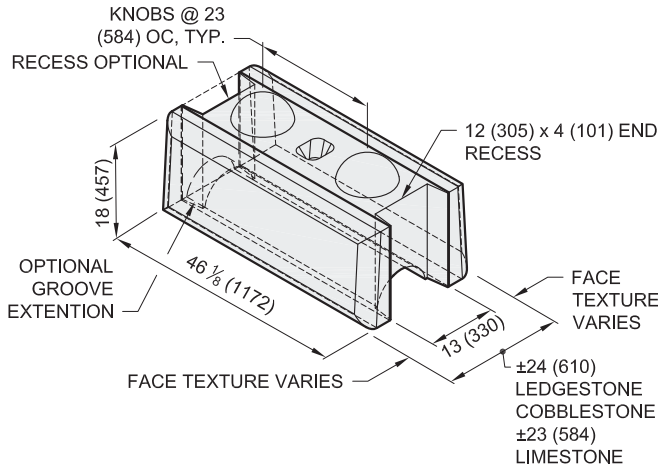

## VARIABLE RADIUS GARDEN TOP

Face Texture:	Cobble / Limestone	Ledgestone
Block Weight:	967 lb (438 kg)	824 lb (374 kg)
Block Volume:	6.76 ft <sup>3</sup> (0.191 m <sup>3</sup> )	5.76 ft <sup>3</sup> (0.163 m <sup>3</sup> )

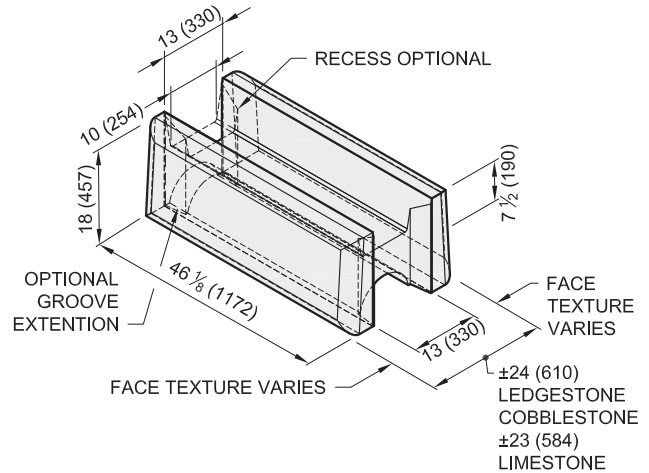

## VARIABLE RADIUS BOTTOM

Face Texture:	Cobble / Limestone	Ledgestone
Block Weight:	1380 lb (626 kg)	1238 lb (561 kg)
Block Volume:	9.65 ft <sup>3</sup> (0.273 m <sup>3</sup> )	8.66 ft <sup>3</sup> (0.245 m <sup>3</sup> )

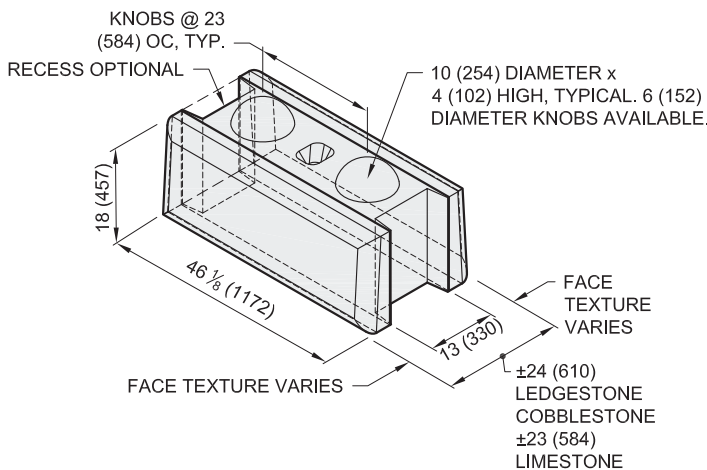

## VARIABLE RADIUS TOP

Face Texture:	Cobble / Limestone	Ledgestone
Block Weight:	1235 lb (560 kg)	1092 lb (495 kg)
Block Volume:	8.63 ft <sup>3</sup> (0.244 m <sup>3</sup> )	7.64 ft <sup>3</sup> (0.216 m <sup>3</sup> )

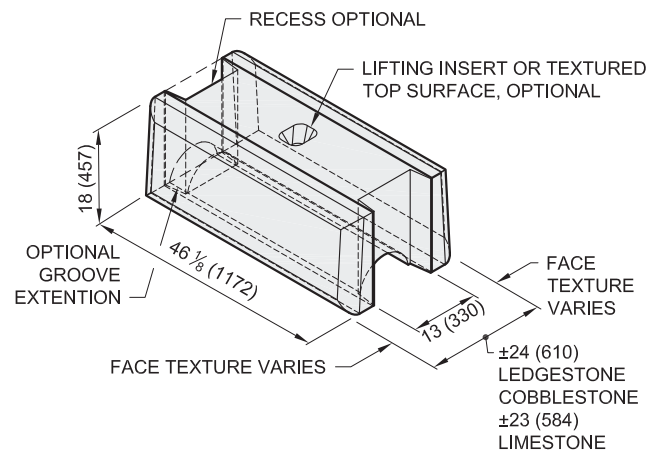

1. Units for dimensions are inches (mm), typical unless noted otherwise.
2. Confirm block production with licensed Redi-Rock manufacturer.
3. Variable radius feature can be cast on only one end, coordinate.
4. Architectural faces on the blocks have varying texture.

5. Actual block volumes and weights may vary.
6. Weights are based upon a concrete density of 143 lb/ft<sup>3</sup> (2291 kg/m<sup>3</sup>).
7. Knobs are typically 10" (254 mm) diameter by 4" (102 mm) tall. Smaller knobs are available.

FREESTANDING BLOCKS

# Block Library

## FORCE PROTECTION MIDDLE

Face Texture:	Cobble / Limestone	Ledgestone
Block Weight:	1345 lb (610 kg)	1203 lb (546 kg)
Block Volume:	9.41 ft <sup>3</sup> (0.267 m <sup>3</sup> )	8.42 ft <sup>3</sup> (0.238 m <sup>3</sup> )

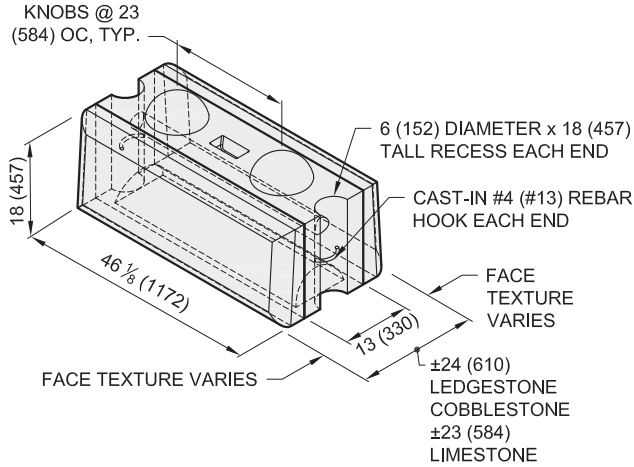

## FORCE PROTECTION TOP

Face Texture:	Cobble / Limestone	Ledgestone
Block Weight:	1314 lb (596 kg)	1171 lb (531 kg)
Block Volume:	9.19 ft <sup>3</sup> (0.260 m <sup>3</sup> )	8.19 ft <sup>3</sup> (0.232 m <sup>3</sup> )

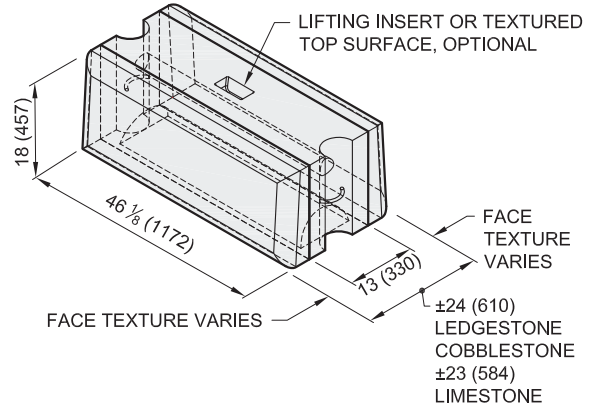

## FORCE PROTECTION BOTTOM

Face Texture:	Cobble / Limestone	Ledgestone
Block Weight:	1463 lb (663 kg)	1320 lb (599 kg)
Block Volume:	10.23 ft <sup>3</sup> (0.290 m <sup>3</sup> )	9.23 ft <sup>3</sup> (0.261 m <sup>3</sup> )

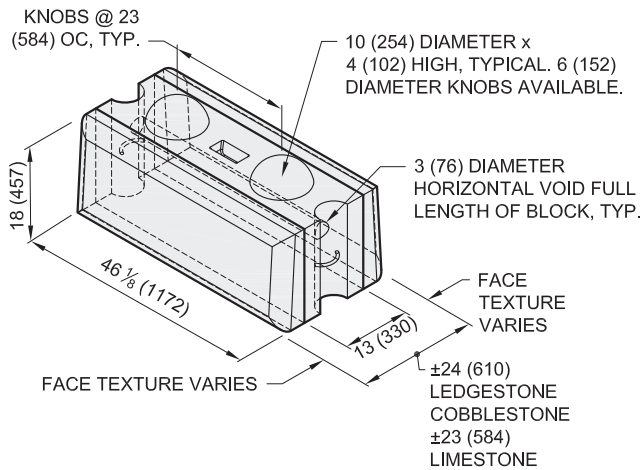

## BARRIER BLOCK

Block Weight:	9,350 lb (4,240 kg)
Block Volume:	65.4 ft <sup>3</sup> (1.85 m <sup>3</sup> )

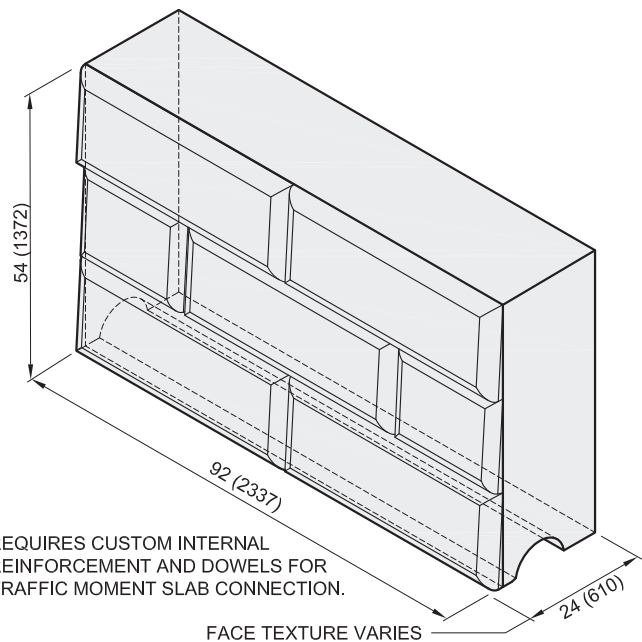

1. Units for dimensions are inches (mm), typical unless noted otherwise.
2. Confirm block production with licensed Redi-Rock manufacturer.
3. Architectural faces on the blocks have varying texture.
4. Actual block volumes and weights may vary.

5. Weights are based upon a concrete density of 143 lb/ft<sup>3</sup> (2291 kg/m<sup>3</sup>).
6. Knobs are typically 10" (254mm) diameter by 4" (102 mm) tall. Smaller knobs are available.

FREESTANDING BLOCKS

# Block Library

## CORNER MIDDLE

Face Texture:	Limestone	Cobblestone	Ledgestone
Block Weight:	1370 lb (620kg)	1390 lb (630 kg)	1360 lb (617kg)
Block Volume:	9.6 ft <sup>3</sup> (0.27m <sup>3</sup> )	9.7 ft <sup>3</sup> (0.28m <sup>3</sup> )	9.5 ft <sup>3</sup> (0.27m <sup>3</sup> )

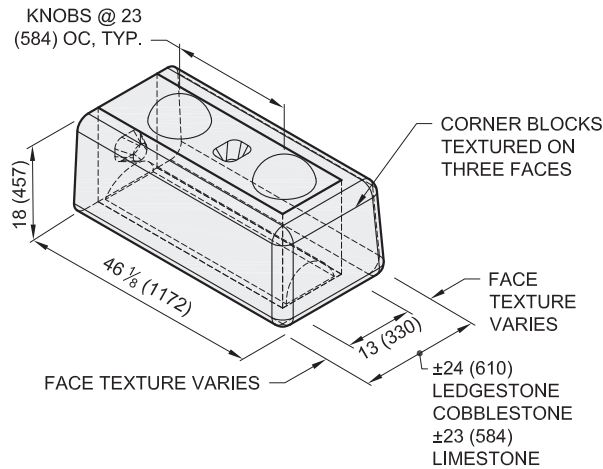

## CORNER GARDEN TOP

Face Texture:	Limestone	Cobblestone	Ledgestone
Block Weight:	1070 lb (480kg)	1080 lb (490 kg)	1060 lb (480kg)
Block Volume:	7.5 ft <sup>3</sup> (0.21m <sup>3</sup> )	7.6 ft <sup>3</sup> (0.22m <sup>3</sup> )	7.4 ft <sup>3</sup> (0.21m <sup>3</sup> )

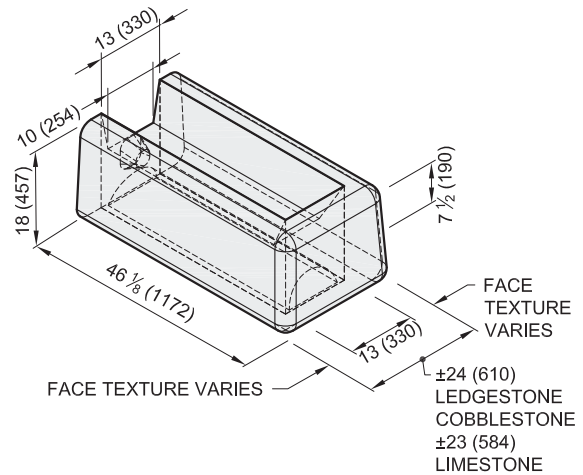

## CORNER BOTTOM

Face Texture:	Limestone	Cobblestone	Ledgestone
Block Weight:	1490 lb (680kg)	1510 lb (680 kg)	1480 lb (670kg)
Block Volume:	10.4 ft <sup>3</sup> (0.30m <sup>3</sup> )	10.5 ft <sup>3</sup> (0.30m <sup>3</sup> )	10.3 ft <sup>3</sup> (0.29m <sup>3</sup> )

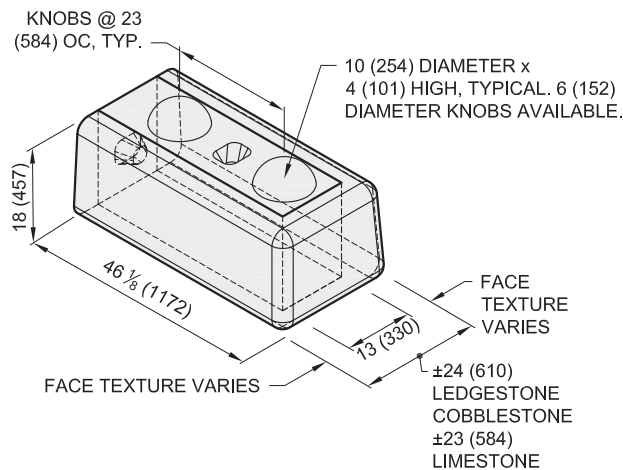

## CORNER TOP

Face Texture:	Limestone	Cobblestone	Ledgestone
Block Weight:	1340 lb (610kg)	1360 lb (620 kg)	1330 lb (600kg)
Block Volume:	9.4 ft <sup>3</sup> (0.26m <sup>3</sup> )	9.5 ft <sup>3</sup> (0.27m <sup>3</sup> )	9.3 ft <sup>3</sup> (0.26m <sup>3</sup> )

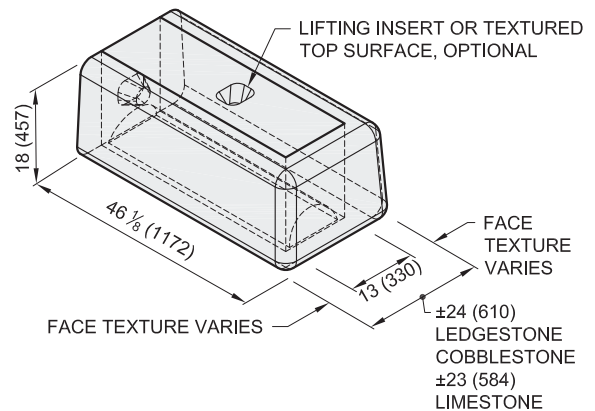

1. Units for dimensions are inches (mm), typical unless noted otherwise.
2. Confirm block production with licensed Redi-Rock manufacturer.
3. Architectural faces on the blocks have varying texture.
4. Actual block volumes and weights may vary.

5. Weights are based upon a concrete density of 143 lb/ft<sup>3</sup> (2291 kg/m<sup>3</sup>).
6. Knobs are typically 10" (254mm) diameter by 4" (102 mm) tall. Smaller knobs are available.

FREESTANDING BLOCKS

# Block Library

## HALF CORNER MIDDLE

Face Texture:	Limestone	Cobblestone	Ledgestone
Block Weight:	660 lb (300kg)	690 lb (310 kg)	650 lb (300kg)
Block Volume:	4.6 ft <sup>3</sup> (0.13m <sup>3</sup> )	4.8 ft <sup>3</sup> (0.14m <sup>3</sup> )	4.6 ft <sup>3</sup> (0.13m <sup>3</sup> )

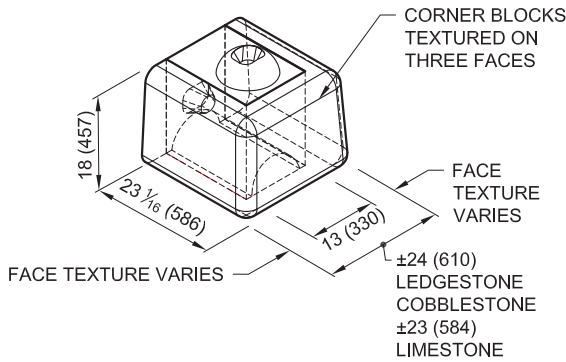

## HALF CORNER GARDEN TOP

Face Texture:	Limestone	Cobblestone	Ledgestone
Block Weight:	530 lb (240kg)	570 lb (260 kg)	530 lb (240kg)
Block Volume:	3.7 ft <sup>3</sup> (0.11m <sup>3</sup> )	4.0 ft <sup>3</sup> (0.11m <sup>3</sup> )	3.7 ft <sup>3</sup> (0.10m <sup>3</sup> )

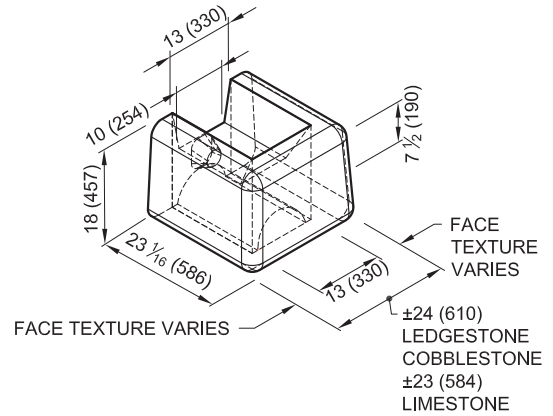

## HALF CORNER BOTTOM

Face Texture:	Limestone	Cobblestone	Ledgestone
Block Weight:	710 lb (320kg)	740 lb (340 kg)	700 lb (320kg)
Block Volume:	5.0 ft <sup>3</sup> (0.14m <sup>3</sup> )	5.2 ft <sup>3</sup> (0.15m <sup>3</sup> )	4.9 ft <sup>3</sup> (0.14m <sup>3</sup> )

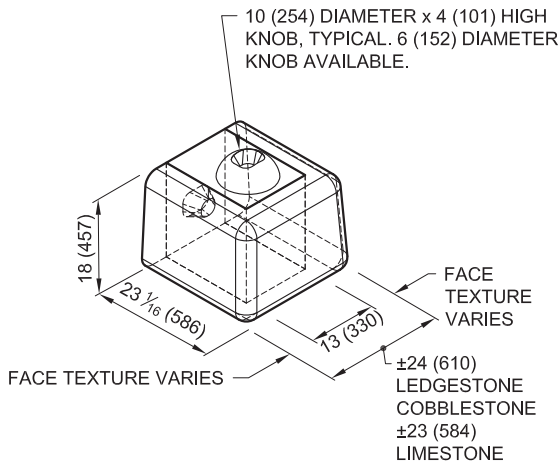

## HALF CORNER TOP

Face Texture:	Limestone	Cobblestone	Ledgestone
Block Weight:	640 lb (290kg)	670 lb (310 kg)	630 lb (290kg)
Block Volume:	4.5 ft <sup>3</sup> (0.13m <sup>3</sup> )	4.7 ft <sup>3</sup> (0.13m <sup>3</sup> )	4.4 ft <sup>3</sup> (0.13m <sup>3</sup> )

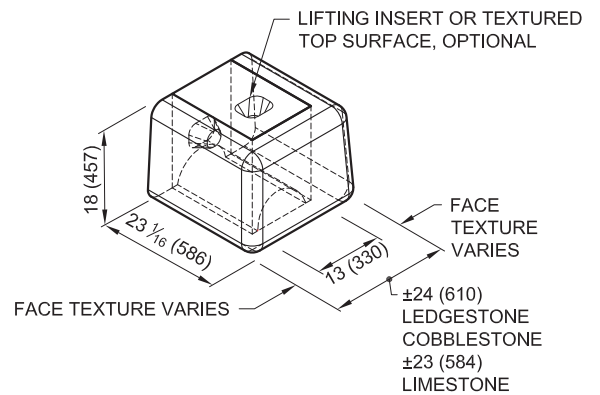

1. Units for dimensions are inches (mm), typical unless noted otherwise.
2. Confirm block production with licensed Redi-Rock manufacturer.
3. Architectural faces on the blocks have varying texture.
4. Actual block volumes and weights may vary.

5. Weights are based upon a concrete density of 143 lb/ft<sup>3</sup> (2291 kg/m<sup>3</sup>).
6. Knobs are typically 10" (254mm) diameter by 4" (102 mm) tall. Smaller knobs are available.

FREESTANDING BLOCKS

# Block Library

## 9" (230) STEPDOWN

Face Texture:	Cobble / Limestone	Ledgestone
Block Weight:	740 lb (335 kg)	660 lb (300 kg)
Block Volume:	5.17 ft <sup>3</sup> (0.146 m <sup>3</sup> )	4.60 ft <sup>3</sup> (0.130 m <sup>3</sup> )

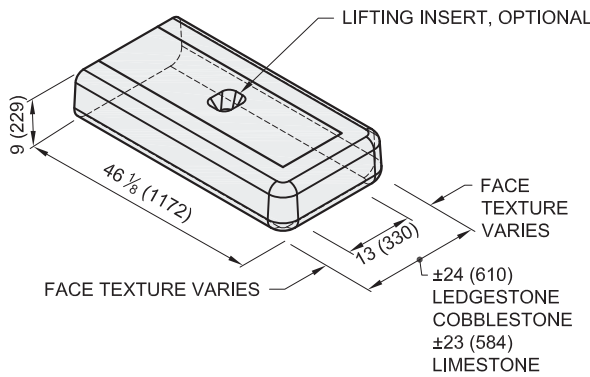

## 9" (230) STEPDOWN GARDEN

Face Texture:	Cobble / Limestone	Ledgestone
Block Weight:	553 lb (251 kg)	471 lb (214 kg)
Block Volume:	3.86 ft <sup>3</sup> (0.109 m <sup>3</sup> )	3.30 ft <sup>3</sup> (0.093 m <sup>3</sup> )

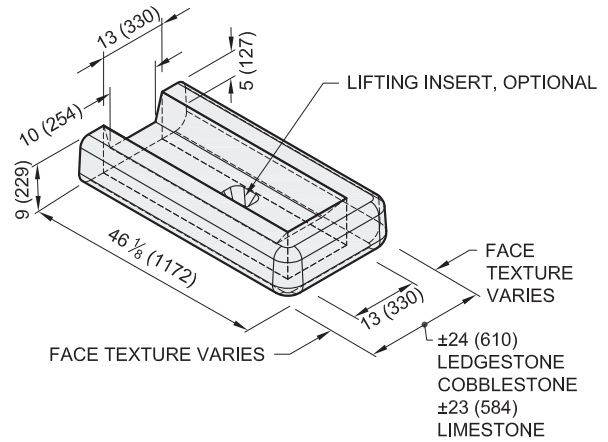

## 90 DEGREE CORNER

Face Texture:	Limestone	Cobblestone	Ledgestone
Block Weight:	1330 lb (600kg)	1350 lb (610 kg)	1320 lb (600kg)
Block Volume:	9.3 ft <sup>3</sup> (0.26m <sup>3</sup> )	9.4 ft <sup>3</sup> (0.27m <sup>3</sup> )	9.2 ft <sup>3</sup> (0.26m <sup>3</sup> )

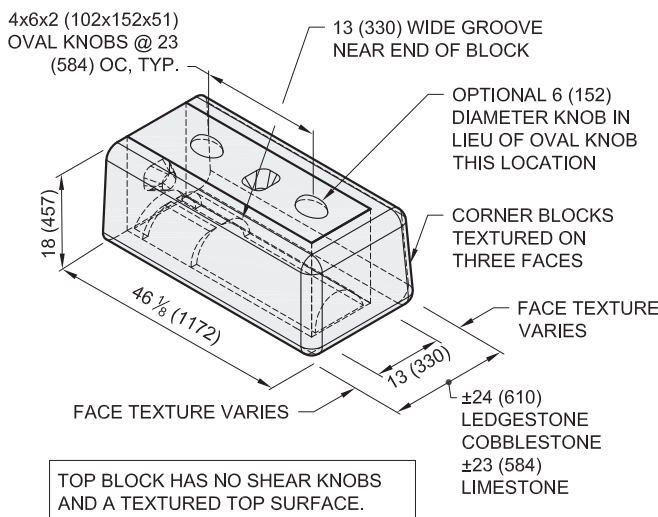

- Units for dimensions are inches (mm), typical unless noted otherwise.
- Confirm block production with licensed Redi-Rock manufacturer.
- Architectural faces on the blocks have varying texture.
- Actual block volumes and weights may vary.
- Weights are based upon a concrete density of 143 lb/ft<sup>3</sup> (2291 kg/m<sup>3</sup>).



## ACCESSORY BLOCKS (COLUMNS, STEPS, AND CAPS)

The Redi-Rock Column and Accessory blocks come in multiple widths and configurations. The defining characteristic is that these blocks have an aesthetic texture cast into two or more faces, and create columns, caps, and steps that complement both Retaining and Freestanding blocks. These blocks are machine-placed, wet-cast, precast modular block units manufactured from first purpose, non-reconstituted concrete and intended for constructing dry-stacked modular features that coordinate with retaining walls. The block units are manufactured from structural-grade concrete mixes in accordance with ASTM C94 or ASTM C685 that produce a finished unit with excellent resistance to freeze-thaw, deicing chemical exposure, and submerged conditions in both fresh water and salt water applications. All Redi-Rock blocks are manufactured and distributed through an international network of individually-owned, licensed precast concrete manufacturers.

### CONCRETE MIX PROPERTIES <sup>(1)</sup>

FREEZE THAW EXPOSURE CLASS <sup>(2)</sup>	MINIMUM 28 DAY COMPRESSIVE STRENGTH <sup>(3)</sup>	MAXIMUM WATER CEMENT RATIO	NOMINAL MAXIMUM AGGREGATE SIZE <sup>(10)</sup>	AGGREGATE CLASS DESIGNATION <sup>(4)</sup>	AIR CONTENT <sup>(5)</sup>
MODERATE	4,000 psi (27.6 MPa)	0.45	1.0 (25)	3M	4.5% ± 1.5%
SEVERE	4,000 psi (27.6 MPa)	0.45	1.0 (25)	3S	6.0% ± 1.5%
VERY SEVERE	4,500 psi (30.0 MPa)	0.40	1.0 (25)	4S	6.0% ± 1.5%
MAXIMUM WATER-SOLUBLE CHLORIDE ION (Cl <sup>-</sup> ) CONTENT IN CONCRETE, PERCENT BY WEIGHT OF CEMENT <sup>(6)</sup>					0.015
MAXIMUM CHLORIDE AS Cl <sup>-</sup> CONCENTRATION IN MIXING WATER, PARTS PER MILLION					1000
MAXIMUM PERCENTAGE OF TOTAL CEMENTITIOUS MATERIALS BY WEIGHT <sup>(7,9)</sup> (VERY SEVERE EXPOSURE CLASS ONLY)					
FLY ASH OR OTHER POZZOLANS PER ASTM C618		25	TOTAL ASH, POZZOLANS, SLAG, AND SILICA FUME <sup>(8)</sup>		50
SLAG CONFORMING TO ASTM C989		50	TOTAL ASH, POZZOLANS, AND SILICA FUME <sup>(8)</sup>		35
SILICA FUME CONFORMING TO ASTM C1240		10	ALKALI-AGGREGATE REACTIVITY MITIGATION PER ACI 201		

### REFERENCE DIMENSIONS:

HEIGHT = VERTICAL DIMENSION OF TEXTURED FACE  
 LENGTH = LONGER HORIZONTAL DIMENSION OF TEXTURED FACE  
 WIDTH = SHORTER HORIZONTAL DIMENSION

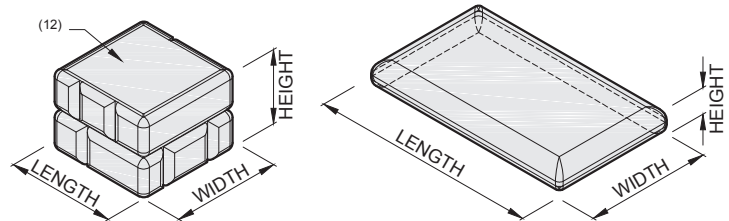

**COLUMN BLOCK**

**CAP/ STEP BLOCK**

### DIMENSIONAL TOLERANCES <sup>(10)(11)</sup>

	COLUMN BLOCKS	CAP/ STEP BLOCKS
HEIGHT	18 ± 3/16 (457 ± 5)	6 ± 3/16 (152 ± 5)
LENGTH	24 ± 1/2 (610 ± 13)	VARIABLES ± 1/2 (VARIABLES ± 13)
WIDTH	24 ± 1/2 (610 ± 13)	28 1/2 ± 1/2 (724 ± 13)

<sup>(1)</sup> Concrete mix properties are in general accordance with ACI 318 durability requirements. Research has shown that concrete manufactured to these standards demonstrates good durability and performance. When these requirements are followed, specific freeze-thaw testing of the concrete is typically NOT required.

<sup>(2)</sup> Exposure class is as described in ACI 318.

<sup>(3)</sup> Test method ASTM C39.

<sup>(4)</sup> Defined in ASTM C33 Table 3 *Limits for Deleterious Substances and Physical Property Requirements of Coarse Aggregate for Concrete*.

<sup>(5)</sup> Test method ASTM C231.

<sup>(6)</sup> Test method ASTM C1218 at age between 28 and 42 days.

<sup>(7)</sup> The total cementitious material also includes ASTM C150, C595, C845, and C1157 cement. The maximum percentages shall include:

(a) Fly ash or other pozzolans in type IP, blended cement, ASTM C595, or ASTM C1157.

(b) Slag used in the manufacture of an IS blended cement, ASTM C595, or ASTM C1157.

(c) Silica fume, ASTM C1240, present in a blended cement.

<sup>(8)</sup> Fly ash or other pozzolans and silica fume shall constitute no more than 25 and 10 percent, respectively, of the total weight of the cementitious materials.

<sup>(9)</sup> Prescriptive limits shown may be waived for concrete mixes that demonstrate excellent freeze-thaw durability in a detailed and current testing program.

<sup>(10)</sup> All dimensions are shown in units of *inches (mm)*.

<sup>(11)</sup> Permissible defects: Chips smaller than 1.5" (38mm) in its largest dimension and cracks not wider than 0.012" (0.305mm) and not longer than 25% of the nominal height of the block; bug holes in the architectural face smaller than 0.75" (19mm); and bug holes, water marks, and color variation on non-architectural faces.

<sup>(12)</sup> Column blocks have a smooth troweled finish on horizontal faces.

ACCESSORIES (CAP AND STEP BLOCKS)

# Block Library

## TWO-SIDED

Block Weight: 631 lb (286 kg)  
 Block Volume: 4.42 ft<sup>3</sup> (0.125 m<sup>3</sup>)

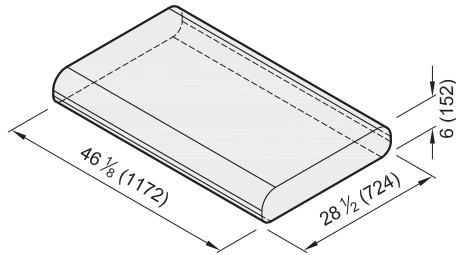

## FOUR-SIDED

Block Weight: 665 lb (302 kg)  
 Block Volume: 4.65 ft<sup>3</sup> (0.132 m<sup>3</sup>)

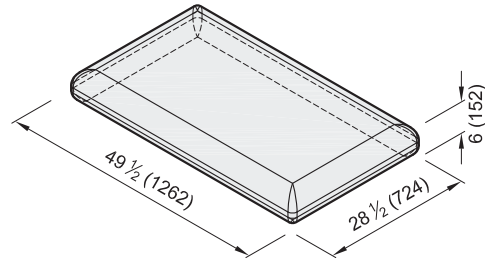

1. Units for dimensions are inches (mm), typical unless noted otherwise.
2. Confirm block production with licensed Redi-Rock manufacturer.

3. Actual block volumes and weights may vary.
4. Weights are based upon a concrete density of 143 lb/ft<sup>3</sup> (2291 kg/m<sup>3</sup>).

ACCESSORIES (COLUMN BLOCKS)

# Block Library

## COLUMN - 8" (203mm) CORE

Block Weight: 730 lb (330 kg)  
 Block Volume: 5.1 ft<sup>3</sup> (0.14 m<sup>3</sup>)

CENTERED THRU TAPERED HOLE  
 8-10 (200-250) DIAMETERS

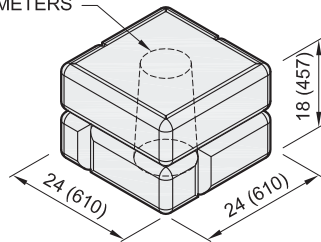

## COLUMN - 4" (102mm) CORE

Block Weight: 810 lb (370 kg)  
 Block Volume: 5.6 ft<sup>3</sup> (0.16 m<sup>3</sup>)

CENTERED 4 (102) DIAMETER  
 PVC PIPE SLEEVE THRU BLOCK

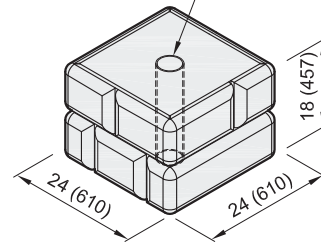

## COLUMN - SOLID CORE

Block Weight: 825 lb (375 kg)  
 Block Volume: 5.8 ft<sup>3</sup> (0.16 m<sup>3</sup>)

OPTIONAL FENCE POCKET

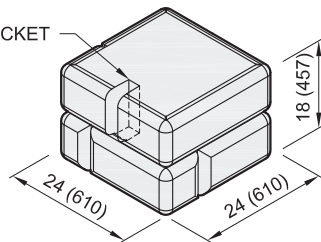

## COLUMN CAP

Block Weight: 390 lb (180 kg)  
 Block Volume: 2.7 ft<sup>3</sup> (0.08 m<sup>3</sup>)

OPTIONAL 4 (102) DIAMETER  
 THRU CENTER HOLE

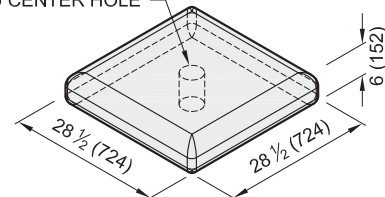

1. Units for dimensions are inches (mm), typical unless noted otherwise.
2. Confirm block production with licensed Redi-Rock manufacturer.
3. Actual block volumes and weights may vary.
4. Weights are based upon a concrete density of 143 lb/ft<sup>3</sup> (2291 kg/m<sup>3</sup>).

5. Weight and volume ranges represents the blocks with the maximum hole size shown and with no hole.
6. Optional fence rail pockets available upon request. Typical pocket size is: 2 (50) wide x 5 (130) deep x 9 (230) tall.

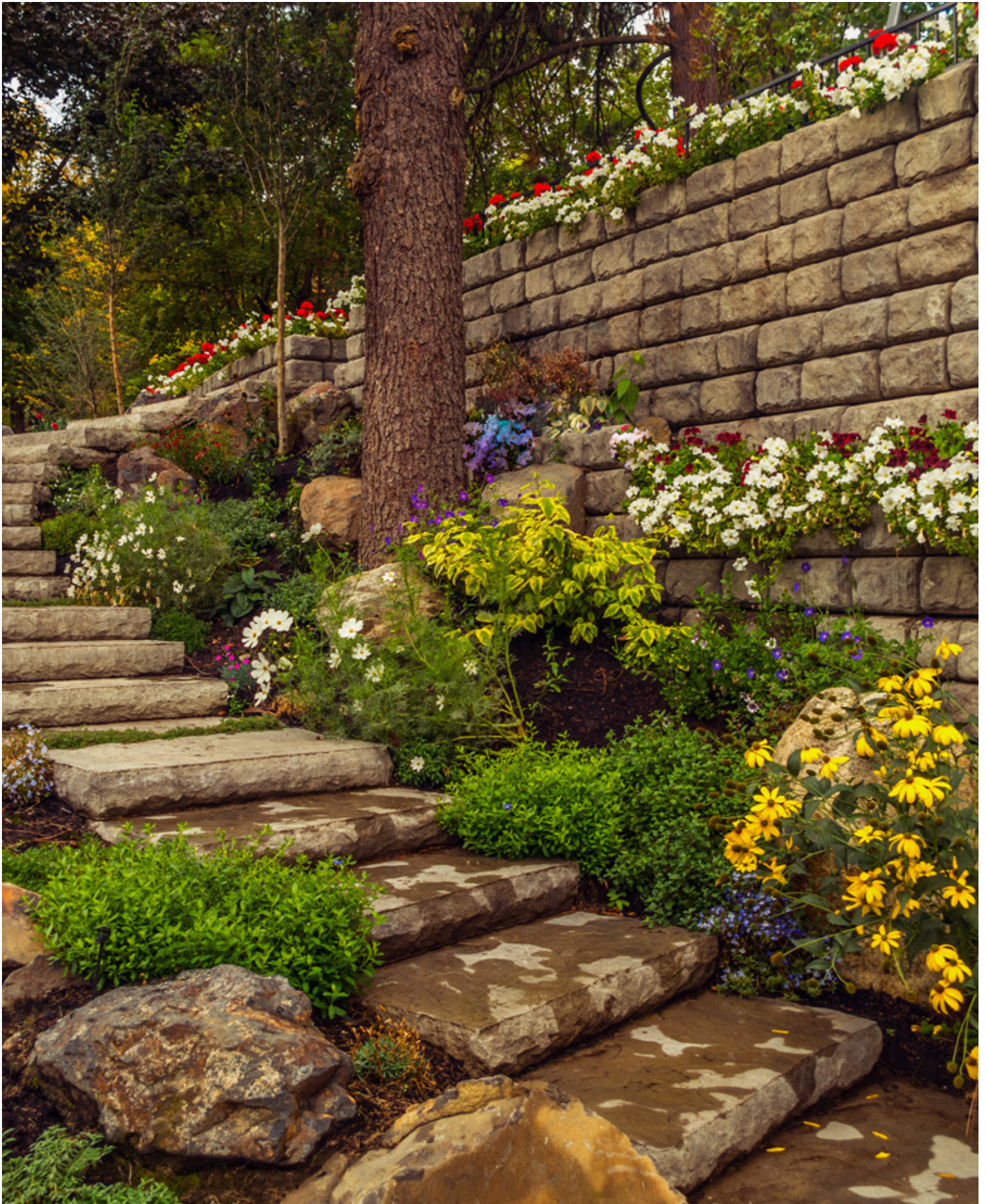





DESIGN INFORMATION

RETAINING BLOCKS

# Infill Weight Calculations

## 28" (710 mm) MIDDLE BLOCK WITH SOIL INFILL

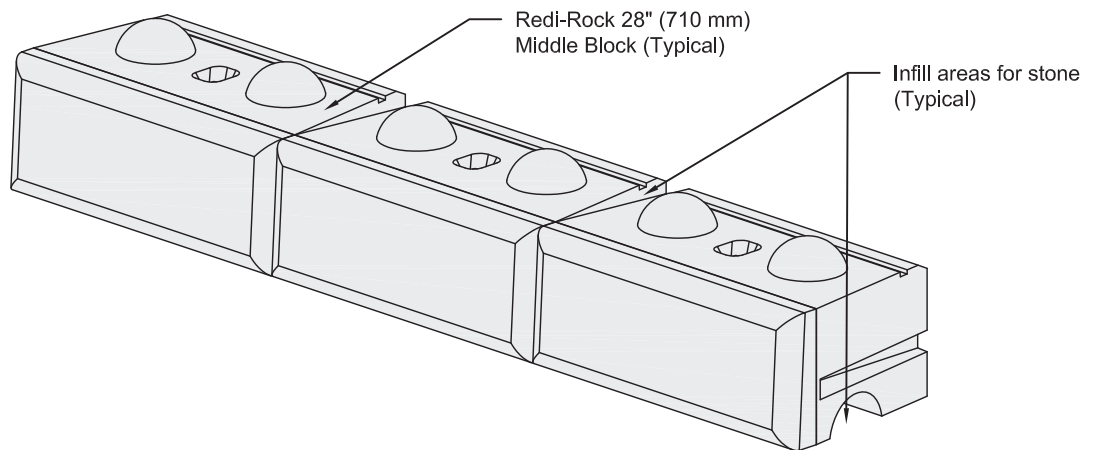
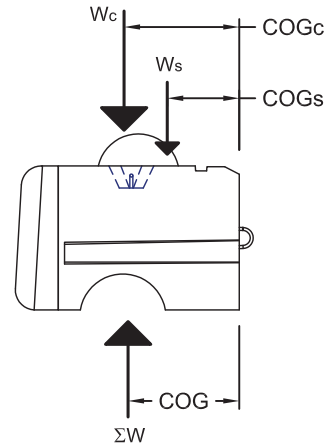
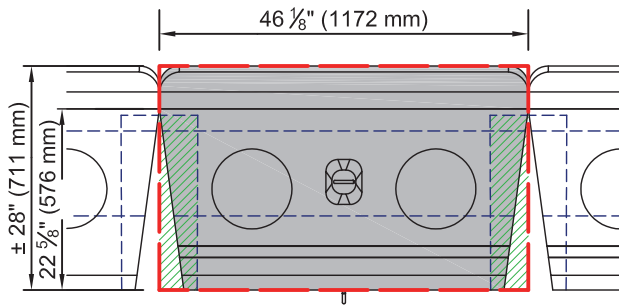

### INFILLED UNIT WEIGHT CALCULATIONS

#### CONCRETE

Design Unit Weight = 143 pcf (2291 kg/m<sup>3</sup>)

#### LIMESTONE AND COBBLESTONE FACE TEXTURE

Average Volume (Vc) 11.28 cft (0.32 m<sup>3</sup>) (From CAD Model)  
 Concrete Block Weight (Wc) Wc = 11.28 cft x 143 pcf = 1,613 lbs (732 kg)

#### LEDGESTONE FACE TEXTURE

Average Volume (Vc) 10.78 cft (0.31 m<sup>3</sup>) (From CAD Model)  
 Concrete Block Weight (Wc) Wc = 10.78 cft x 143 pcf = 1,542 lbs (699 kg)  
 Average Center of Gravity (COGc) 13.9 in (353 mm) (From CAD Model)

#### INFILL SOIL

Design Unit Weight = 100 pcf (1602 kg/m<sup>3</sup>)

Soil considered as infill includes the soil between adjacent blocks and at the ends of the bottom groove in the block.

Volume (Vs) 1.05 cft (0.03 m<sup>3</sup>) (From CAD Model)  
 Infill Soil Weight (Ws) Ws = 1.05 cft x 100 pcf = 105 lbs (47.7 kg)  
 Center of Gravity (COGs) 13.6 in (345 mm) (Data from CAD Model)

#### DESIGN VOLUME

28 in x 46.125 in x 18 in = 13.45 cft  
 (0.711 m x 1.172 m x 0.457 m = 0.38m<sup>3</sup>)

#### INFILLED UNIT WEIGHT

##### LIMESTONE AND COBBLESTONE FACE TEXTURE

$\gamma_{INFILL} = (1,613 \text{ lb} + 105 \text{ lb}) / 13.45 \text{ cft} = \mathbf{127.7 \text{ pcf}}$   
 ((733 kg + 48 kg) / 0.381 m<sup>3</sup> = 2045 kg/m<sup>3</sup>)

##### LEDGESTONE FACE TEXTURE

$\gamma_{INFILL} = (1,542 \text{ lb} + 105 \text{ lb}) / 13.45 \text{ cft} = \mathbf{122.4 \text{ pcf}}$   
 ((701 kg + 48 kg) / 0.381 m<sup>3</sup> = 1960 kg/m<sup>3</sup>)

NOTE: The infilled unit weights shown here are reference values. Several factors can cause the unit weights of both concrete and infill soil to vary. The designer should use sound engineering judgement when assigning an infilled unit weight value for analysis.

RETAINING BLOCKS

# Infill Weight Calculations

## 28" (710 mm) POSITIVE CONNECTION (PC) MIDDLE BLOCK WITH SOIL INFILL

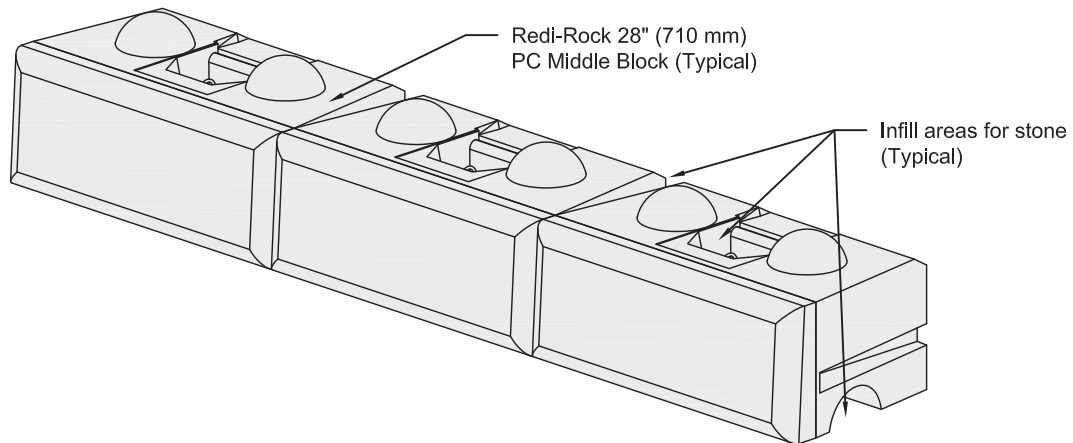
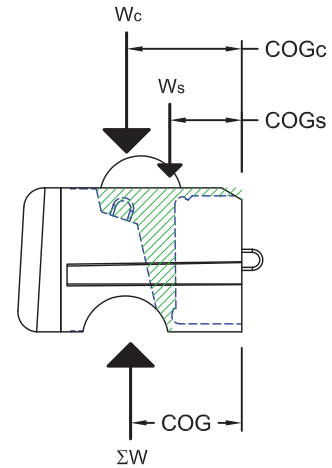
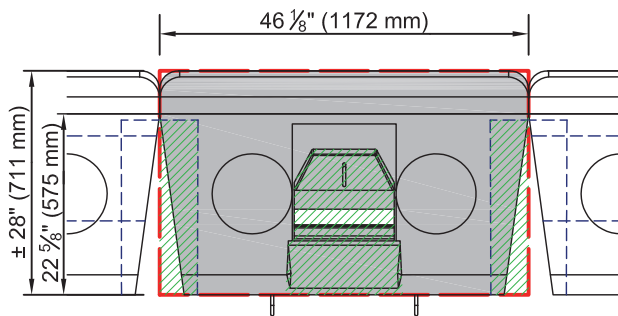

### INFILLED UNIT WEIGHT CALCULATIONS

#### CONCRETE

Design Unit Weight = 143 pcf (2291 kg/m<sup>3</sup>)

#### LIMESTONE AND COBBLESTONE FACE TEXTURE

Average Volume (Vc) 10.62 cft (0.30 m<sup>3</sup>) (From CAD Model)  
 Concrete Block Weight (Wc) Wc = 10.62 cft x 143 pcf = 1,519 lbs (690 kg)

#### LEDGESTONE FACE TEXTURE

Average Volume (Vc) 10.12 cft (0.29 m<sup>3</sup>) (From CAD Model)  
 Concrete Block Weight (Wc) Wc = 10.12 cft x 143 pcf = 1,447 lbs (658 kg)  
 Average Center of Gravity (COGc) 14.0 in (356 mm) (From CAD Model)

#### INFILL SOIL

Design Unit Weight = 100 pcf (1602 kg/m<sup>3</sup>)

Soil considered as infill includes the soil between adjacent blocks, in the geogrid slot, and at the ends of the bottom groove in the block.

Volume (Vs) 1.73 cft (0.05 m<sup>3</sup>) (From CAD Model)  
 Infill Soil Weight (Ws) Ws = 1.73 cft x 100 pcf = 173 lbs (79 kg)  
 Center of Gravity (COGs) 9.9 in (251 mm) (Data from CAD Model)

#### DESIGN VOLUME

28 in x 46.125 in x 18 in = 23,247 in<sup>3</sup> = 13.45 cft  
 (0.711 m x 1.172 m x 0.457 m = 0.38m<sup>3</sup>)

#### INFILLED UNIT WEIGHT

##### LIMESTONE AND COBBLESTONE FACE TEXTURE

$\gamma_{INFILL} = (1,519 \text{ lb} + 173 \text{ lb}) / 13.45 \text{ cft} = \mathbf{125.8 \text{ pcf}}$   
 ((690 kg + 79 kg) / 0.381 m<sup>3</sup> = 2015 kg/m<sup>3</sup>)

##### LEDGESTONE FACE TEXTURE

$\gamma_{INFILL} = (1,447 \text{ lb} + 173 \text{ lb}) / 13.45 \text{ cft} = \mathbf{120.4 \text{ pcf}}$   
 ((658 kg + 79 kg) / 0.381 m<sup>3</sup> = 1629 kg/m<sup>3</sup>)

NOTE: The infilled unit weights shown here are reference values. Several factors can cause the unit weights of both concrete and infill soil to vary. The designer should use sound engineering judgement when assigning an infilled unit weight value for analysis.

RETAINING BLOCKS

# Infill Weight Calculations

## 41" (1030 mm) MIDDLE BLOCK WITH SOIL INFILL

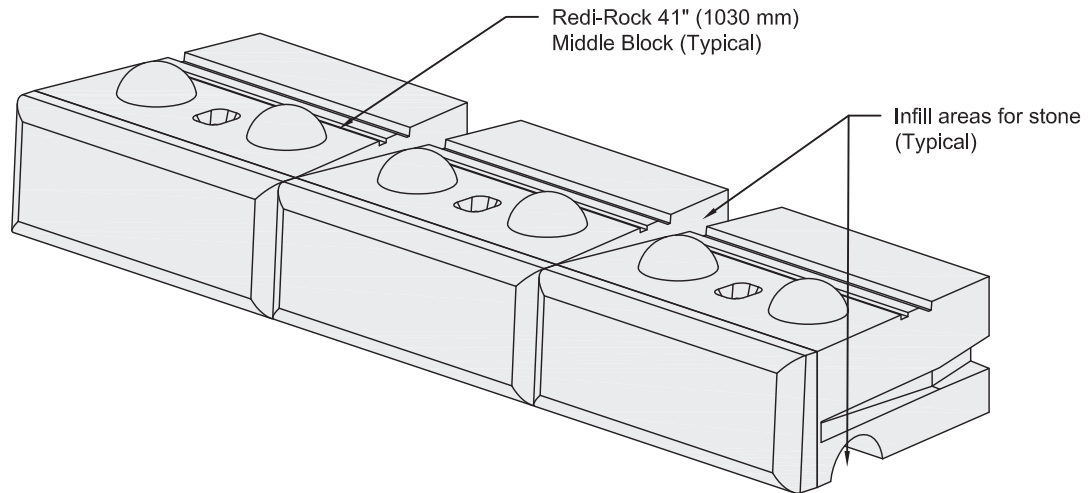
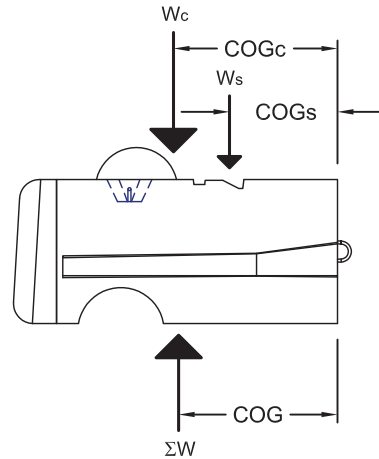
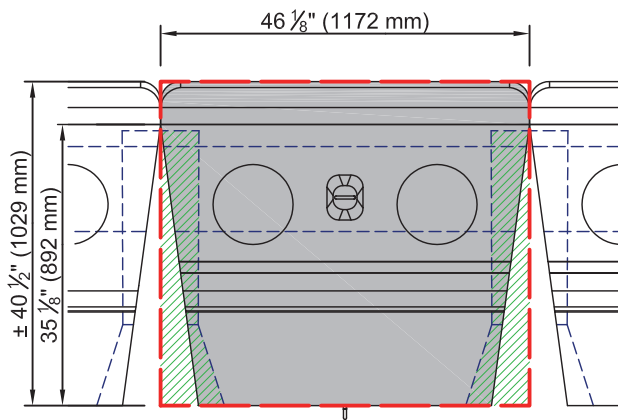

### INFILLED UNIT WEIGHT CALCULATIONS

#### CONCRETE

Design Unit Weight = 143 pcf (2291 kg/m<sup>3</sup>)

#### LIMESTONE AND COBBLESTONE FACE TEXTURE

Average Volume (Vc) 16.14 cft (0.457 m<sup>3</sup>) (From CAD Model)  
 Concrete Block Weight (Wc) Wc = 16.14 cft x 143 pcf = 2,308 lbs (1048 kg)

#### LEDGESTONE FACE TEXTURE

Average Volume (Vc) 15.65 cft (0.443 m<sup>3</sup>) (From CAD Model)  
 Concrete Block Weight (Wc) Wc = 15.65 cft x 143 pcf = 2,238 lbs (1015 kg)  
 Average Center of Gravity (COGc) 20.5 in (521 mm) (From CAD Model)

#### INFILL SOIL

Design Unit Weight = 100 pcf (1602 kg/m<sup>3</sup>)

Soil considered as infill includes the soil between adjacent blocks and at the ends of the bottom groove in the block.

Volume (Vs) 2.18 cft (0.062 m<sup>3</sup>) (From CAD Model)  
 Infill Soil Weight (Ws) Ws = 2.18 cft x 100 pcf = 218 lbs (99.1 kg)  
 Center of Gravity (COGs) 13.5 in (342 mm) (Data from CAD Model)

#### DESIGN VOLUME

40.5 in x 46.125 in x 18 in = 19.46 cft  
 (1.03 m x 1.172 m x 0.457 m = 0.55 m<sup>3</sup>)

#### INFILLED UNIT WEIGHT

##### LIMESTONE AND COBBLESTONE FACE TEXTURE

$\gamma_{INFILL} = (2,308 \text{ lb} + 218 \text{ lb}) / 19.46 \text{ cft} = \mathbf{129.8 \text{ pcf}}$   
 ((1049 kg + 99 kg) / 0.551 m<sup>3</sup> = 2079 kg/m<sup>3</sup>)

##### LEDGESTONE FACE TEXTURE

$\gamma_{INFILL} = (2,238 \text{ lb} + 218 \text{ lb}) / 19.46 \text{ cft} = \mathbf{126.2 \text{ pcf}}$   
 ((1017 kg + 99 kg) / 0.551 m<sup>3</sup> = 2021 kg/m<sup>3</sup>)

NOTE: The infilled unit weights shown here are reference values. Several factors can cause the unit weights of both concrete and infill soil to vary. The designer should use sound engineering judgement when assigning an infilled unit weight value for analysis.

RETAINING BLOCKS

# Infill Weight Calculations

## 41" (1030 mm) POSITIVE CONNECTION (PC) MIDDLE BLOCK WITH SOIL INFILL

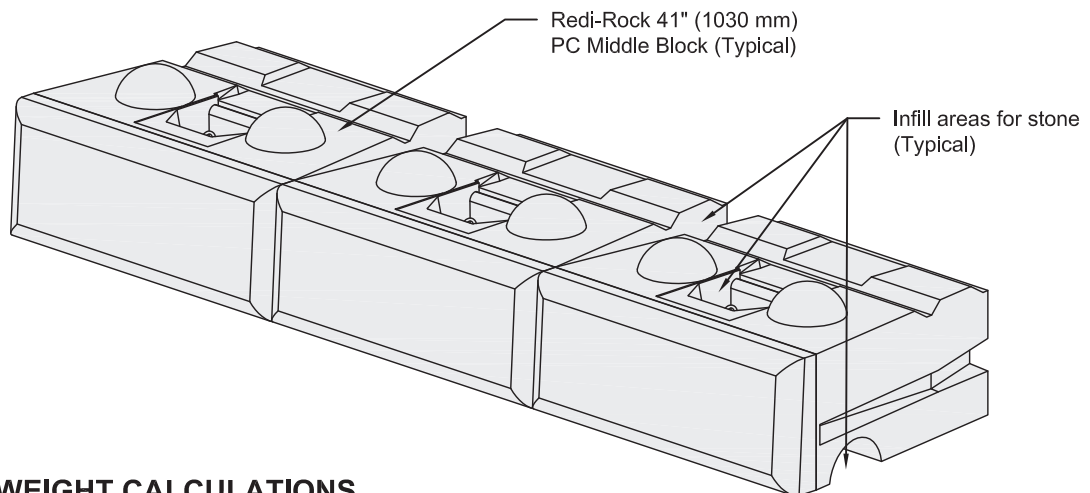
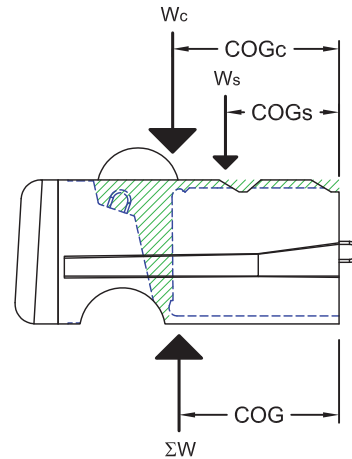
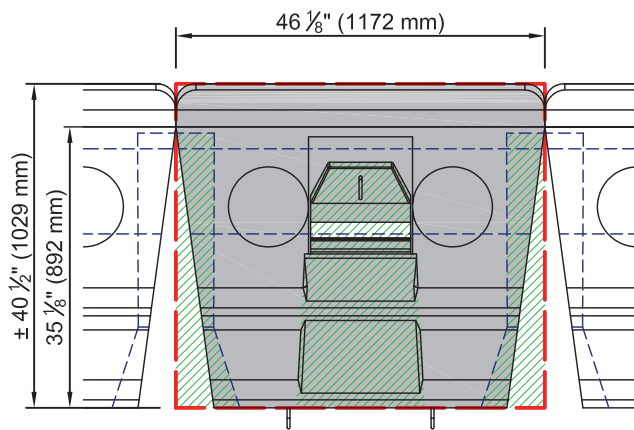

### INFILLED UNIT WEIGHT CALCULATIONS

**CONCRETE**

Design Unit Weight = 143 pcf (2291 kg/m<sup>3</sup>)

**LIMESTONE AND COBBLESTONE FACE TEXTURE**

Average Volume (Vc) 15.19 cft (0.43 m<sup>3</sup>) (From CAD Model)  
 Concrete Block Weight (Wc) Wc = 15.19 cft x 143 pcf = 2,172 lbs (987 kg)

**LEDGESTONE FACE TEXTURE**

Average Volume (Vc) 14.69 cft (0.42 m<sup>3</sup>) (From CAD Model)  
 Concrete Block Weight (Wc) Wc = 14.69 cft x 143 pcf = 2,101 lbs (955 kg)  
 Average Center of Gravity (COGc) 20.4 in (518 mm) (From CAD Model)

**INFILL SOIL**

Design Unit Weight = 100 pcf (1602 kg/m<sup>3</sup>)

Soil considered as infill includes the soil between adjacent blocks, in the geogrid slot, and at the ends of the bottom groove in the block.

Volume (Vs) 2.92 cft (0.08 m<sup>3</sup>) (From CAD Model)  
 Infill Soil Weight (Ws) Ws = 2.92 cft x 100 pcf = 292 lbs (133 kg)  
 Center of Gravity (COGs) 15.6 in (396 mm) (Data from CAD Model)

**DESIGN VOLUME**

40.5 in x 46.125 in x 18 in = 33,625 in<sup>3</sup> = 19.46 cft  
 (1.03 m x 1.172 m x 0.457 m = 0.55 m<sup>3</sup>)

**INFILLED UNIT WEIGHT**

**LIMESTONE AND COBBLESTONE FACE TEXTURE**

$\gamma_{INFILL} = (2,172 \text{ lb} + 292 \text{ lb}) / 19.46 \text{ cft} = \mathbf{126.6 \text{ pcf}}$   
 ((987 kg x 133 kg) / 0.551 m<sup>3</sup> = 2030 kg/m<sup>3</sup>)

**LEDGESTONE FACE TEXTURE**

$\gamma_{INFILL} = (2,101 \text{ lb} + 292 \text{ lb}) / 19.46 \text{ cft} = \mathbf{123.0 \text{ pcf}}$   
 ((955 kg x 133 kg) / 0.551 m<sup>3</sup> = 1970 kg/m<sup>3</sup>)

NOTE: The infilled unit weights shown here are reference values. Several factors can cause the unit weights of both concrete and infill soil to vary. The designer should use sound engineering judgement when assigning an infilled unit weight value for analysis.

RETAINING BLOCKS

# Infill Weight Calculations

## 60" (1520 mm) MIDDLE BLOCK WITH SOIL INFILL

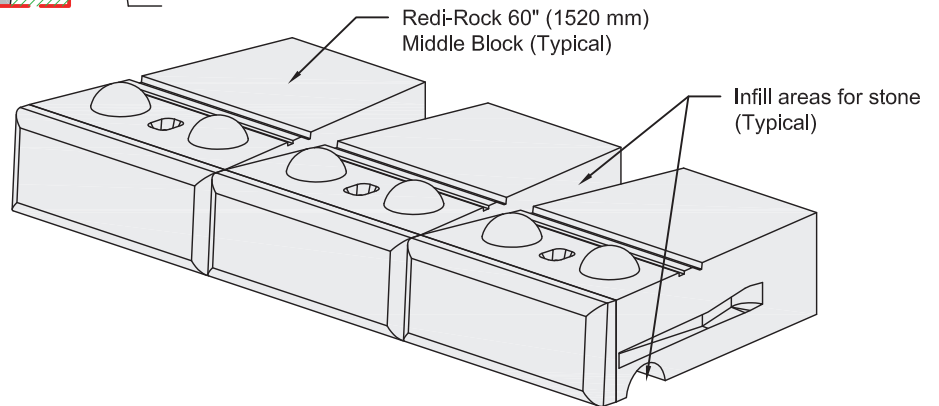
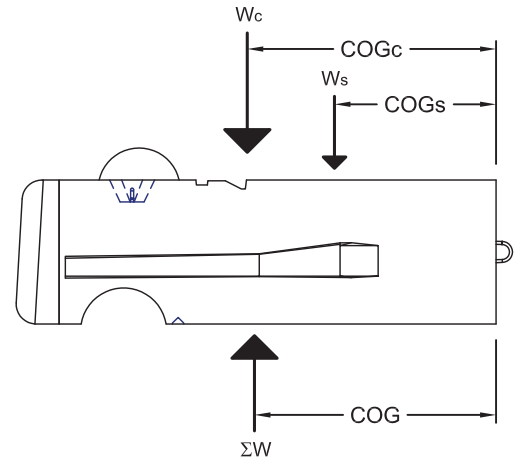
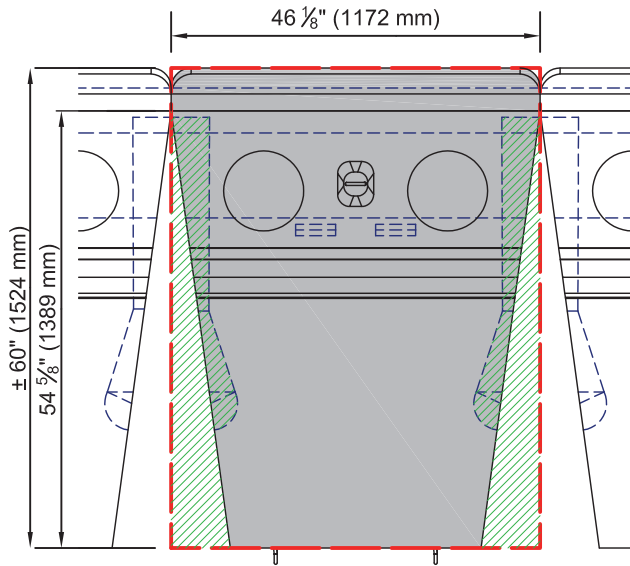

### INFILLED UNIT WEIGHT CALCULATIONS

**CONCRETE**

Design Unit Weight = 143 pcf (2291 kg/m<sup>3</sup>)

**LIMESTONE AND COBBLESTONE FACE TEXTURE**

Average Volume (Vc) 23.00 cft (0.651m<sup>3</sup>) (From CAD Model)  
 Concrete Block Weight (Wc) Wc = 23.0 cft x 143 pcf = 3,287 lbs (1491 kg)

**LEDGESTONE FACE TEXTURE**

Average Volume (Vc) 22.49 cft (0.637 m<sup>3</sup>) (From CAD Model)  
 Concrete Block Weight (Wc) Wc = 22.49 cft x 143 pcf = 3,216 lbs (1458 kg)  
 Average Center of Gravity (COGc) 31.1 in (790 mm) (From CAD Model)

**INFILL SOIL**

Design Unit Weight = 100 pcf (1602 kg/m<sup>3</sup>)

Soil considered as infill includes the soil between adjacent blocks and at the ends of the bottom groove in the block.

Volume (Vs) 4.70 cft (0.133 m<sup>3</sup>) (From CAD Model)  
 Infill Soil Weight (Ws) Ws = 4.70 cft x 100 pcf = 470 lbs (214 kg)  
 Center of Gravity (COGs) 20.2 in (513mm) (Data from CAD Model)

**DESIGN VOLUME**

60 in x 46.125 in x 18 in = 28.83 cft  
 (1.524 m x 1.172 m x 0.457 m = 0.816 m<sup>3</sup>)

**INFILLED UNIT WEIGHT**

**LIMESTONE AND COBBLESTONE FACE TEXTURE**

$\gamma_{INFILL} = (3,288 \text{ lb} + 470 \text{ lb}) / 28.83 \text{ cft} = \mathbf{130.4 \text{ pcf}}$   
 ((1495 kg + 214 kg) / 0.816 m<sup>3</sup> = 2089 kg/m<sup>3</sup>)

**LEDGESTONE FACE TEXTURE**

$\gamma_{INFILL} = (3,216 \text{ lb} + 470 \text{ lb}) / 28.83 \text{ cft} = \mathbf{127.9 \text{ pcf}}$   
 ((1462 kg + 214 kg) / 0.816 m<sup>3</sup> = 2050 kg/m<sup>3</sup>)

NOTE: The infilled unit weights shown here are reference values. Several factors can cause the unit weights of both concrete and infill soil to vary. The designer should use sound engineering judgement when assigning an infilled unit weight value for analysis.

RETAINING BLOCKS

# Infill Weight Calculations

## 60" (1520 MM) BOTTOM BLOCK WITH SOIL INFILL

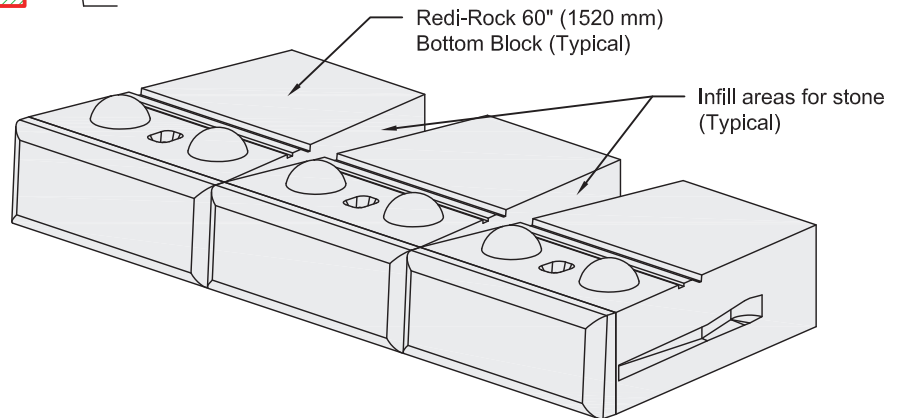
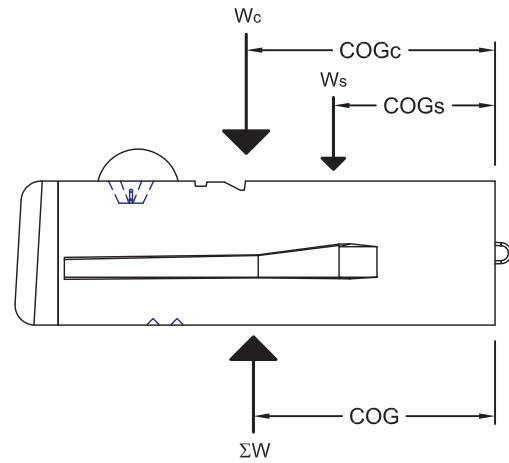
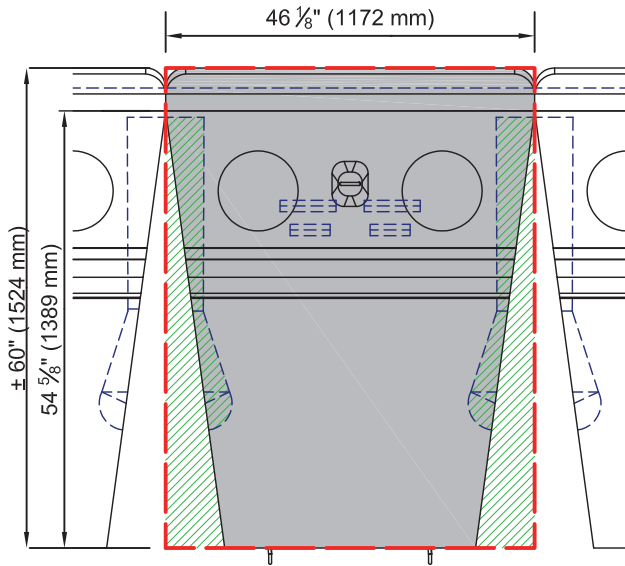

### INFILLED UNIT WEIGHT CALCULATIONS

#### CONCRETE

Design Unit Weight = 143 pcf (2291 kg/m<sup>3</sup>)

#### LIMESTONE AND COBBLESTONE FACE TEXTURE

Average Volume (Vc) 23.90 cft (0.677 m<sup>3</sup>) (From CAD Model)

Concrete Block Weight (Wc) Wc = 23.90 cft x 143 pcf = 3,418 lbs

#### LEDGESTONE FACE TEXTURE

Average Volume (Vc) 23.40 cft (From CAD Model)

Concrete Block Weight (Wc) Wc = 23.40 cft x 143 pcf = 3,346 lbs

Average Center of Gravity (COGc) 31.6 in from Back of Block (From CAD Model)

#### INFILL SOIL

Design Unit Weight = 100 pcf (1602 kg/m<sup>3</sup>)

Soil considered as infill includes the soil between adjacent blocks and at the ends of the bottom groove in the block.

Volume (Vs) 4.58 cft (From CAD Model)

Infill Soil Weight (Ws) Ws = 4.58 cft x 100 pcf = 458 lbs

Center of Gravity (COGs) 19.5 in from Back of Block (Data from CAD Model)

#### DESIGN VOLUME

60 in x 46.125 in x 18 in = 49,815 in<sup>3</sup> = 28.83 cft  
(1.524 m x 1.172 m x 0.457 m = 0.816 m<sup>3</sup>)

#### INFILLED UNIT WEIGHT

##### LIMESTONE AND COBBLESTONE FACE TEXTURE

$\gamma_{INFILL} = (3,418 \text{ lb} + 458 \text{ lb}) / 28.83 \text{ cft} = \mathbf{134.4 \text{ pcf}}$   
 $((1554 \text{ kg} + 208 \text{ kg}) / 0.816 \text{ m}^3 = 2153 \text{ kg/m}^3)$

##### LEDGESTONE FACE TEXTURE

$\gamma_{INFILL} = (3,346 \text{ lb} + 458 \text{ lb}) / 28.83 \text{ cft} = \mathbf{131.9 \text{ pcf}}$   
 $((1521 \text{ kg} + 208 \text{ kg}) / 0.816 \text{ m}^3 = 2113 \text{ kg/m}^3)$

NOTE: The infilled unit weights shown here are reference values. Several factors can cause the unit weights of both concrete and infill soil to vary. The designer should use sound engineering judgement when assigning an infilled unit weight value for analysis.

# Block Setback Options

The block-to-block setback available with Redi-Rock is controlled by the size and location of the shear knobs (domes) cast into the blocks. While the 10" (254 mm) diameter knob and the 1 5/8" (41 mm) setback position is the most common configuration, Redi-Rock has three different knob sizes and three different locations available.

## Five degree (5°) setback (Standard)

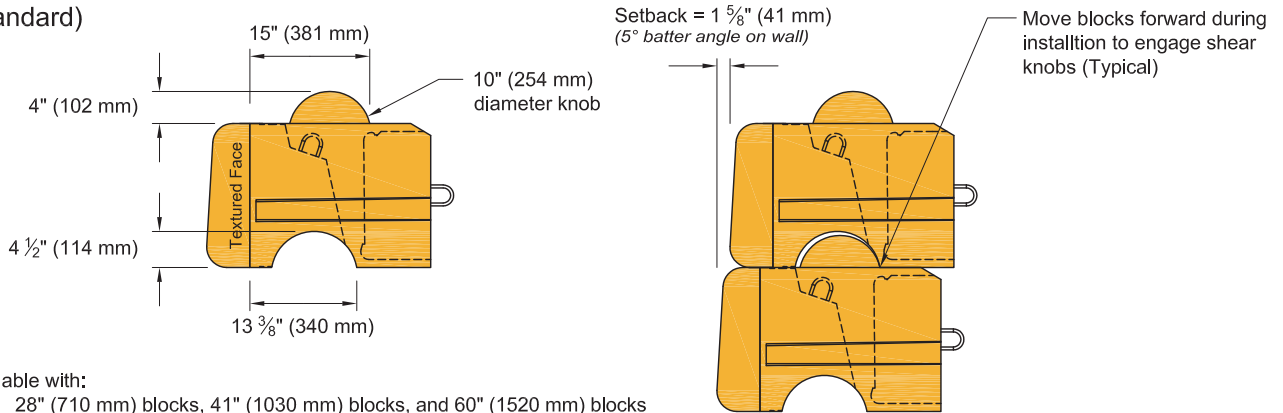

Available with:

- 28" (710 mm) blocks, 41" (1030 mm) blocks, and 60" (1520 mm) blocks
- 28" (710 mm) PC blocks (shown here) and 41" (1030 mm) PC blocks

## One degree (1°) setback (Specialty)

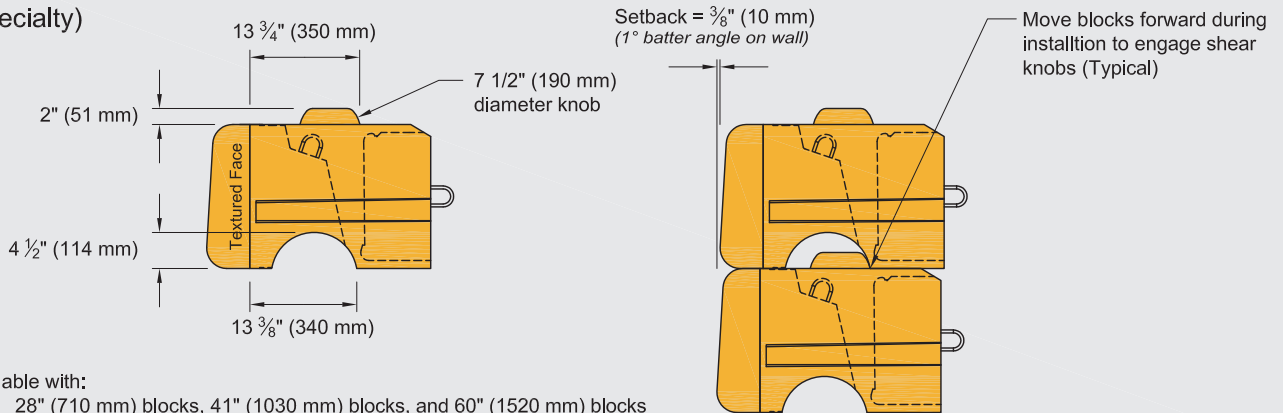

Available with:

- 28" (710 mm) blocks, 41" (1030 mm) blocks, and 60" (1520 mm) blocks
- 28" (710 mm) PC blocks (shown here) and 41" (1030 mm) PC blocks

## Zero (0°) setback (Specialty)

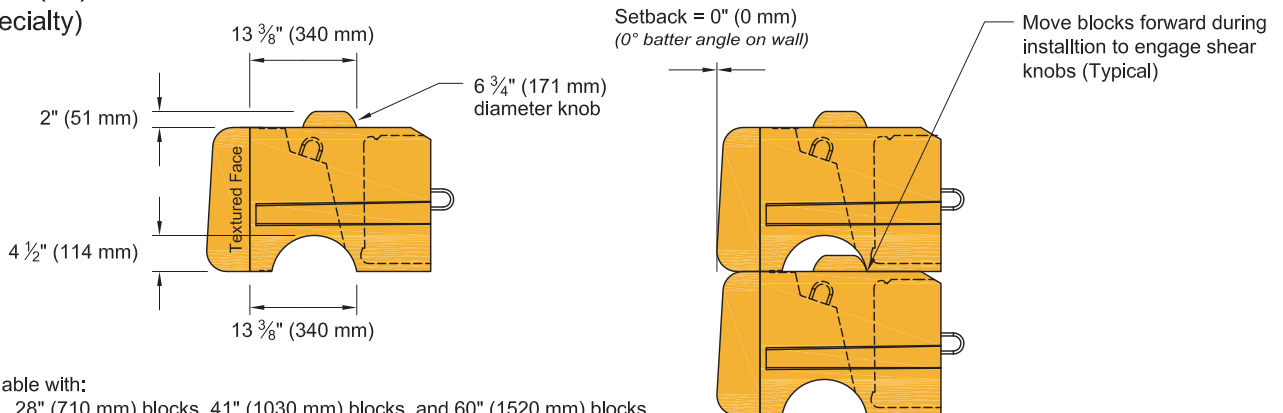

Available with:

- 28" (710 mm) blocks, 41" (1030 mm) blocks, and 60" (1520 mm) blocks
- 28" (710 mm) PC blocks (shown here) and 41" (1030 mm) PC blocks

# Block Setback Options

Redi-Rock has two options for large batter retaining walls. Both options are created by relocating the knob so that it is further back in the Redi-Rock blocks compared to our smaller batter walls (5° and less). There are two knob locations further back in the block which create the 9" (230 mm) setback block and the planter block. Blocks made with knobs in either of these locations almost exclusively use 10" (254 mm) diameter knobs.

## 9" (230 mm) Setback Blocks

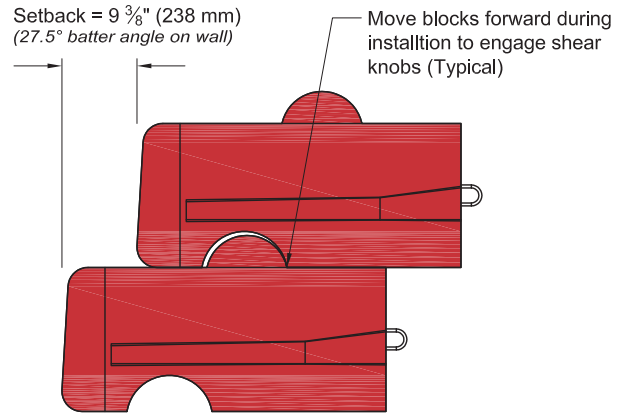
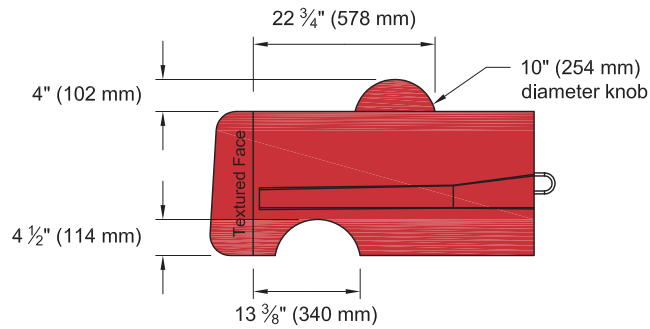

Available with:

- 41" (1030 mm) blocks (shown here) and 60" (1520 mm) blocks
- Not available in PC blocks

## Planter Blocks

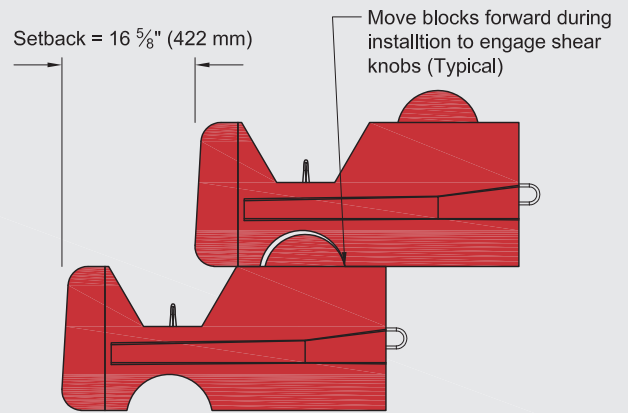
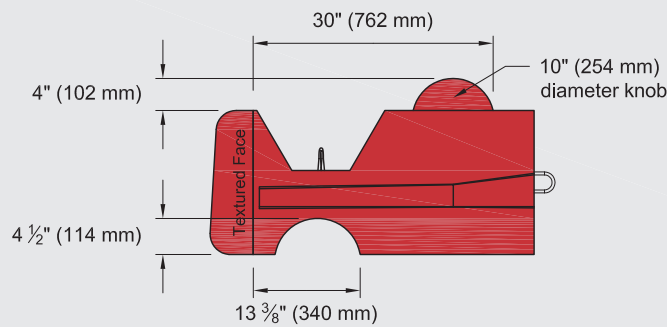

Available with:

- 41" (1030 mm) blocks (shown here) and 60" (1520 mm) blocks
- Not available in PC blocks

# Interface Shear Report 6.75" (171 mm)

Test Methods: ASTM D6916 & NCMA SRWU-2

Test Facility: Bathurst, Clarabut Geotechnical Testing, Inc.

Block Type: 28" (710 mm) Positive Connection (PC) Block

Test Dates: 10/21/2011 - 6.75" (171 mm) Shear Knob Test

## 6.75" (171 mm) KNOB INTERFACE SHEAR DATA<sup>(a)</sup>

Test No.	Normal Load lb/ft (kN/m)	Service State Shear <sup>(b)</sup> lb/ft (kN/m)	Peak Shear lb/ft (kN/m)	Observed Failure <sup>(c)</sup>
1	522 (7.618)	838 (12.230)	1,724 (25.160)	Test Stopped
2	19,209 (280.334)	11,324 (165.261)	11,324 (165.261)	Test Stopped
3	16,303 (237.924)	11,252 (164.211)	11,252 (164.211)	Test Stopped
4	13,612 (198.652)	11,036 (161.058)	11,036 (161.058)	Test Stopped
5	11,075 (161.627)	10,462 (152.681)	10,462 (152.681)	Test Stopped
6	11,074 (161.613)	11,060 (161.409)	11,252 (164.211)	Knob Shear
7	8,299 (121.115)	10,408 (151.893)	11,204 (163.510)	Test Stopped
8	5,854 (85.433)	8,337 (121.669)	9,935 (144.990)	Knob Shear
9	3,077 (44.905)	5,722 (83.506)	6,153 (89.796)	Knob Shear
10	10,981 (160.256)	10,821 (157.921)	11,252 (164.211)	Knob Shear

Peak Shear<sup>(d)</sup>:  $S_p = 1,178 + N \tan 54^\circ \leq 10,970 \text{ lb/ft}$  ( $S_p = 17.19 + N \tan 54^\circ \leq 160.1 \text{ kN/m}$ )

Service State Shear<sup>(d)</sup>:  $S_{ss} = 616 + N \tan 52^\circ \leq 10,970 \text{ lb/ft}$  ( $S_{ss} = 8.99 + N \tan 52^\circ \leq 160.1 \text{ kN/m}$ )

## 6.75" (171 mm) KNOB INTERFACE SHEAR CAPACITY

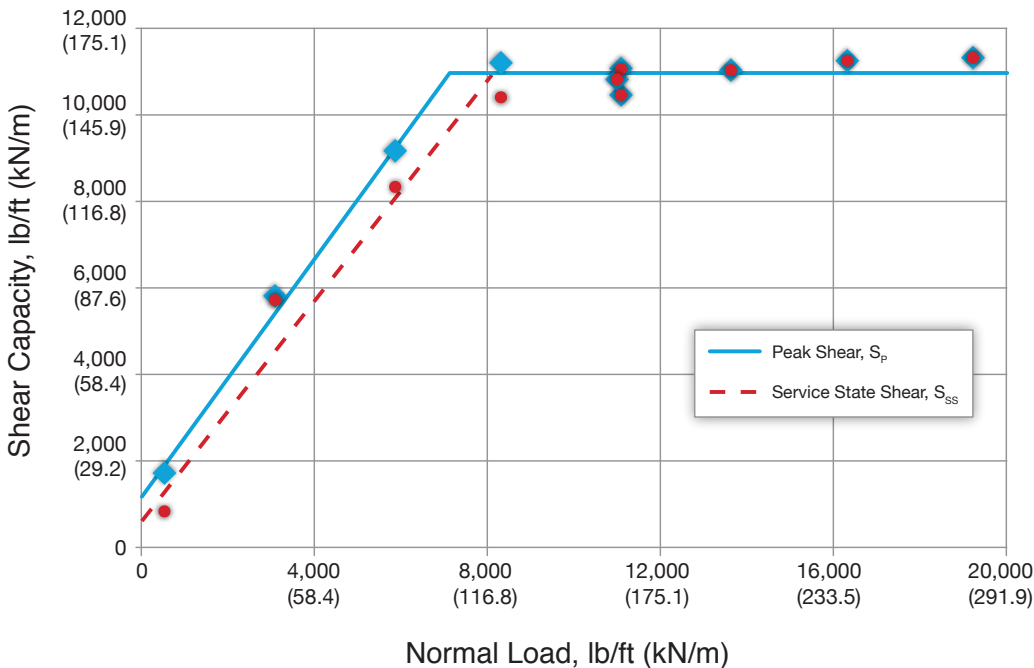

(a) The 28-day compressive strength of all concrete blocks tested in the 10-inch (254-millimeter) knob interface shear test series was 4,474 psi.

(b) Service State Shear is measured at a horizontal displacement equal to 2% of the block height. For Redi-Rock blocks, displacement = 0.36 inches (9.144 millimeters).

(c) In most cases, the test was stopped before block rupture or knob shear occurred to prevent damage to the test apparatus.

(d) Design shear capacity inferred from the test data reported herein should be lowered when test failure results from block rupture or knob shear if the compressive strength of the blocks used in design is less than the blocks used in this test. The data reported represents the actual laboratory test results. The equations for peak and service state shear conditions have been modified to reflect the interface shear performance of concrete with a minimum 28-day compressive strength equal to 4,000 psi. No further adjustments have been made. Appropriate factors of safety for design should be added.

The information contained in this report has been compiled by Redi-Rock International, LLC as a recommendation of peak interface shear capacity. It is accurate to the best of our knowledge as of the date of its issue. However, final determination of the suitability of any design information and the appropriateness of this data for a given design purpose is the sole responsibility of the user. No warranty of performance is expressed or implied by the publishing of the foregoing laboratory test results. Issue date: January 26, 2015.

# Interface Shear Report 10" (254 mm)

Test Methods: ASTM D6916 & NCMA SRWU-2

Test Facility: Bathurst, Clarabut Geotechnical Testing, Inc.

Block Type: 28" (710 mm) Positive Connection (PC) Block

10/14/2011 - 10" (254 mm) Shear Knob Test

## 10" (254 mm) KNOB INTERFACE SHEAR DATA<sup>(a)</sup>

Test No.	Normal Load	Service State Shear <sup>(b)</sup>		Peak Shear		Observed Failure <sup>(c)</sup>
	lb/ft (kN/m)	lb/ft (kN/m)	lb/ft (kN/m)	lb/ft (kN/m)	lb/ft (kN/m)	
1	19,619 (286.318)	11,300 (164.911)	11,300 (164.911)	11,300 (164.911)	11,300 (164.911)	Test Stopped
2	16,007 (233.605)	11,300 (164.911)	11,300 (164.911)	11,300 (164.911)	11,300 (164.911)	Test Stopped
3	13,546 (197.689)	11,371 (165.947)	11,371 (165.947)	11,371 (165.947)	11,371 (165.947)	Test Stopped
4	11,042 (161.146)	11,371 (165.947)	11,371 (165.947)	11,371 (165.947)	11,371 (165.947)	Test Stopped
5	8,400 (122.589)	11,204 (163.510)	11,204 (163.510)	11,204 (163.510)	11,204 (163.510)	Test Stopped
6	10,999 (160.518)	11,252 (164.211)	11,252 (164.211)	11,252 (164.211)	11,252 (164.211)	Test Stopped
7	10,922 (159.395)	11,252 (164.211)	11,252 (164.211)	11,252 (164.211)	11,252 (164.211)	Test Stopped
8	5,786 (84.440)	10,414 (151.981)	10,414 (151.981)	11,156 (162.810)	11,156 (162.810)	Test Stopped
9	3,137 (45.781)	7,469 (109.002)	7,469 (109.002)	10,174 (148.478)	10,174 (148.478)	Test Stopped
10	522 (7.618)	3,926 (57.296)	3,926 (57.296)	6,033 (88.045)	6,033 (88.045)	Test Stopped

Peak Shear:  $S_p = 6,061 + N \tan 44^\circ \leq 11,276 \text{ lb/ft}$  ( $S_p = 88.45 + N \tan 44^\circ \leq 164.56 \text{ kN/m}$ )

Service State Shear:  $S_{ss} = 3,390 + N \tan 51^\circ \leq 11,276 \text{ lb/ft}$  ( $S_{ss} = 49.47 + N \tan 51^\circ \leq 164.56 \text{ kN/m}$ )

## 10" (254 mm) KNOB INTERFACE SHEAR CAPACITY

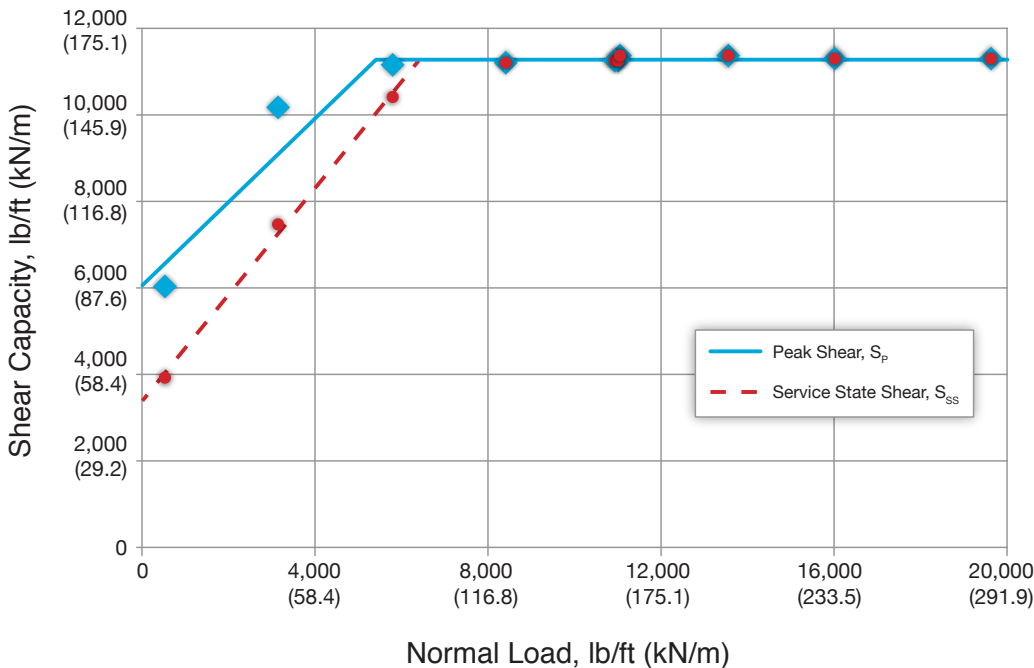

(a) The 28-day compressive strength of all concrete blocks tested in the 10-inch (254-millimeter) knob interface shear test series was 4,474 psi.

(b) Service State Shear is measured at a horizontal displacement equal to 2% of the block height. For Redi-Rock blocks, displacement = 0.36 inches (9.144 millimeters).

(c) In most cases, the test was stopped before block rupture or knob shear occurred to prevent damage to the test apparatus.

(d) Design shear capacity inferred from the test data reported herein should be lowered when test failure results from block rupture or knob shear if the compressive strength of the blocks used in design is less than the blocks used in this test. The data reported represents the actual laboratory test results. The equations for peak and service state shear conditions have been modified to reflect the interface shear performance of concrete with a minimum 28-day compressive strength equal to 4,000 psi. No further adjustments have been made. Appropriate factors of safety for design should be added.

The information contained in this report has been compiled by Redi-Rock International, LLC as a recommendation of peak interface shear capacity. It is accurate to the best of our knowledge as of the date of its issue. However, final determination of the suitability of any design information and the appropriateness of this data for a given design purpose is the sole responsibility of the user. No warranty of performance is expressed or implied by the publishing of the foregoing laboratory test results. Issue date: January 26, 2015.

# Geogrid Connection Design Parameters—Miragrid 5XT

Test Methods: ASTM D6638 & NCMA SRWU-1

Test Facility: Bathurst, Clarabut Geotechnical Testing, Inc.

Geogrid Type: Miragrid 5XT

Test Date: February 17, 2011

Block Type: Positive Connection (PC) Block

## CONNECTION STRENGTH TEST DATA<sup>(a)</sup>

Test No.	Normal Load		Peak Connection		Observed Failure
	lb/ft	(kN/m)	lb/ft	(kN/m)	
1	2,236	(32.6)	5,040	(73.6)	Grid Rupture
2	775	(11.3)	4,860	(70.9)	Grid Rupture
3	5,165	(75.4)	4,444	(64.9)	Grid Rupture
4	2,242	(32.7)	4,343	(63.4)	Grid Rupture
5	1,649	(24.1)	4,658	(68.0)	Grid Rupture
6	3,123	(45.6)	4,680	(68.3)	Grid Rupture
7	2,236	(32.6)	4,838	(70.6)	Grid Rupture
8	3,991	(58.2)	4,444	(64.9)	Grid Rupture

Peak Connection<sub>(average)</sub> = 4,663 lb/ft (68.1 kN/m)

Peak Connection<sub>(95% confidence level)<sup>(b)</sup></sub> = 4,460 lb/ft (65.1 kN/m)

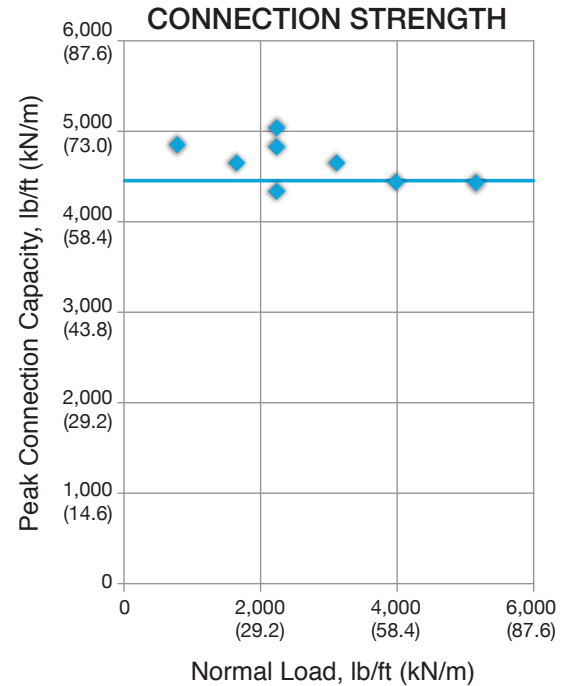

## CONNECTION DESIGN DATA

for use with AASHTO LRFD Bridge Design Specifications, 6th Edition (2012)

Miragrid 5XT Ultimate Tensile Strength (MARV)  $T_{ult} = 4,700$  lb/ft (68.1 kN/m)

Ultimate Connection Strength  $T_{ultconn} = 4,460$  lb/ft (65.1 kN/m)

Ultimate Tensile Strength of Geosynthetic Test Sample  $T_{lot} = 5,334$  lb/ft (77.8 kN/m)

Connection Strength / Sample Strength  $T_{ultconn} / T_{lot} = 0.84$

Short-term Ultimate Connection Strength Reduction Factor<sup>(c)</sup>  $CR_u = 0.84$

### Creep Reduction Factor

75-Year Design  $RF_{cr(75)} = 1.56$

100-Year Design  $RF_{cr(100)} = 1.58$

Durability Reduction Factor<sup>(d)</sup>  $RF_D = 1.15$

### Long-term Connection Strength Reduction Factor

75-Year Design  $CR_{cr(75)} = 0.54$

100-Year Design  $CR_{cr(100)} = 0.53$

### Nominal Long-term Geosynthetic Connection Strength

75-Year Design  $T_{ac(75)} = 2,201$  lb/ft (32.1 kN/m)

100-Year Design  $T_{ac(100)} = 2,173$  lb/ft (31.7 kN/m)

(a) Tested with 3/4 inch (19 mm) clean crushed stone lightly compacted in the vertical core slot in accordance with Redi-Rock International's typical installation recommendations.

(b) Because the geogrid connection is not normal-load dependent and an expression of peak connection for use in design cannot be reliably determined through linear regression, the peak connection results are analyzed as continuous random variables. The average value or sample mean is reported for the test sample as well as a reduction based upon a 95% confidence interval calculated from the Student's t-test for n-1 degrees of freedom.

(c) Recommended  $CR_u$  for design is based on a statistical best-fit analysis of  $T_{ultconn} / T_{lot}$  values across all geogrid types tested.

(d) Recommended value for  $5 < pH < 8$ .  $RF_D$  value of 1.3 recommended for  $4.5 \leq pH \leq 5$  and  $8 \leq pH \leq 9$ .

The information contained in this report has been carefully compiled by Redi-Rock International, LLC as a recommendation of peak connection capacity. It is accurate to the best of our knowledge as of the date of its issue. However, final determination of the suitability of any design information and the appropriateness of this data for a given design purpose is the sole responsibility of the user. No warranty of performance is expressed or implied by the publishing of the foregoing laboratory test results. Issue date: May 12, 2014.

# Geogrid Connection Design Parameters—Miragrid 8XT

Test Methods: ASTM D6638 &amp; NCMA SRWU-1

Test Facility: Bathurst, Clarabut Geotechnical Testing, Inc.

Geogrid Type: Miragrid 8XT

Test Date: December 16, 2011

Block Type: Positive Connection (PC) Block

## CONNECTION STRENGTH TEST DATA<sup>(a)</sup>

Test No.	Normal Load	Peak Connection	Observed Failure
	lb/ft (kN/m)	lb/ft (kN/m)	
1	1,960 (28.6)	7,995 (116.7)	Grid Rupture
2	241 (3.5)	7,949 (116.0)	Grid Rupture
3	1,125 (16.4)	7,904 (115.4)	Grid Rupture
4	2,036 (29.7)	7,949 (116.0)	Grid Rupture
5	2,914 (42.5)	8,269 (120.7)	Grid Rupture
6	3,715 (54.2)	7,995 (116.7)	Grid Rupture
7	1,900 (27.7)	8,452 (123.3)	Grid Rupture
8	4,551 (66.4)	8,269 (120.7)	Grid Rupture

Peak Connection<sub>(average)</sub> = 8,098 lb/ft (118.2 kN/m)Peak Connection<sub>(95% confidence level)<sup>(b)</sup></sub> = 7,928 lb/ft (115.7 kN/m)

## CONNECTION DESIGN DATA

for use with AASHTO LRFD Bridge Design Specifications, 6th Edition (2012)

Miragrid 8XT Ultimate Tensile Strength (MARV)  $T_{ult} = 7,400$  lb/ft (108.0 kN/m)Ultimate Connection Strength  $T_{ultconn} = 7,928$  lb/ft (115.7 kN/m)Ultimate Tensile Strength of Geosynthetic Test Sample  $T_{lot} = 8,055$  lb/ft (117.6 kN/m)Connection Strength / Sample Strength  $T_{ultconn} / T_{lot} = 0.98$ Short-term Ultimate Connection Strength Reduction Factor<sup>(c)</sup>  $CR_u = 0.84$ 

Creep Reduction Factor

75-Year Design  $RF_{cr(75)} = 1.56$ 100-Year Design  $RF_{cr(100)} = 1.58$ Durability Reduction Factor<sup>(d)</sup>  $RF_D = 1.15$ 

Long-term Connection Strength Reduction Factor

75-Year Design  $CR_{cr(75)} = 0.54$ 100-Year Design  $CR_{cr(100)} = 0.53$ 

Nominal Long-term Geosynthetic Connection Strength

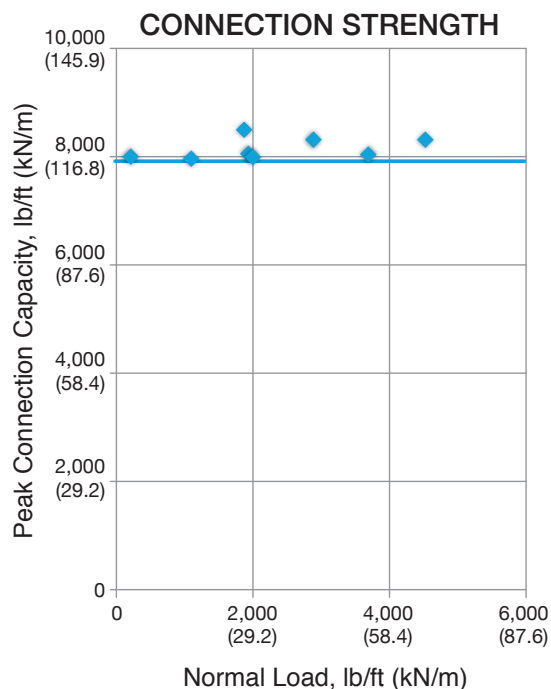
75-Year Design  $T_{ac(75)} = 3,465$  lb/ft (50.6 kN/m)100-Year Design  $T_{ac(100)} = 3,421$  lb/ft (49.9 kN/m)

(a) Tested with 3/4 inch (19 mm) clean crushed stone lightly compacted in the vertical core slot in accordance with Redi-Rock International's typical installation recommendations.

(b) Because the geogrid connection is not normal-load dependent and an expression of peak connection for use in design cannot be reliably determined through linear regression, the peak connection results are analyzed as continuous random variables. The average value or sample mean is reported for the test sample as well as a reduction based upon a 95% confidence interval calculated from the Student's t-test for n-1 degrees of freedom.

(c) Recommended  $CR_u$  for design is based on a statistical best-fit analysis of  $T_{ultconn} / T_{lot}$  values across all geogrid types tested.

(d) Recommended value for  $5 < pH < 8$ .  $RF_D$  value of 1.3 recommended for  $4.5 \leq pH \leq 5$  and  $8 \leq pH \leq 9$ .

The information contained in this report has been carefully compiled by Redi-Rock International, LLC as a recommendation of peak connection capacity. It is accurate to the best of our knowledge as of the date of its issue. However, final determination of the suitability of any design information and the appropriateness of this data for a given design purpose is the sole responsibility of the user. No warranty of performance is expressed or implied by the publishing of the foregoing laboratory test results. Issue date: May 12, 2014.

# Geogrid Connection Design Parameters—Miragrid 10XT

Test Methods: ASTM D6638 & NCMA SRWU-1

Test Facility: Bathurst, Clarabut Geotechnical Testing, Inc.

Geogrid Type: Miragrid 10XT

Test Date: November 28, 2011

Block Type: Positive Connection (PC) Block

## CONNECTION STRENGTH TEST DATA<sup>(a)</sup>

Test No.	Normal Load		Peak Connection		Observed Failure
	lb/ft	(kN/m)	lb/ft	(kN/m)	
1	1,990	(29.0)	9,046	(132.0)	Grid Rupture
2	228	(3.3)	8,452	(123.3)	Grid Rupture
3	1,147	(16.7)	8,589	(125.3)	Grid Rupture
4	2,067	(30.2)	9,365	(136.7)	Grid Rupture
5	2,918	(42.6)	8,863	(129.3)	Grid Rupture
6	3,830	(55.9)	9,594	(140.0)	Grid Rupture
7	2,067	(30.2)	9,000	(131.3)	Grid Rupture
8	4707	(68.7)	9,046	(132.0)	Grid Rupture

Peak Connection<sub>(average)</sub> = 8,994 lb/ft (131.3 kN/m)

Peak Connection<sub>(95% confidence level)<sup>(b)</sup></sub> = 8,681 lb/ft (126.7 kN/m)

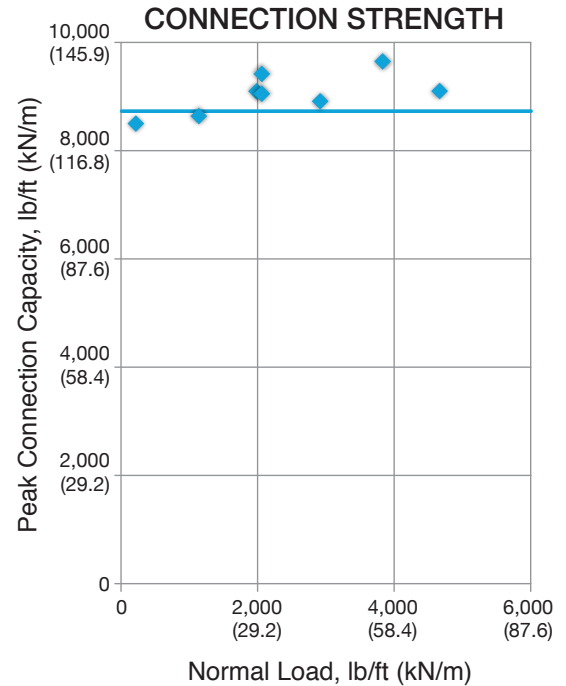

## CONNECTION DESIGN DATA

for use with AASHTO LRFD Bridge Design Specifications, 6th Edition (2012)

Miragrid 10XT Ultimate Tensile Strength (MARV)  $T_{ult} = 9,500$  lb/ft (138.6 kN/m)

Ultimate Connection Strength  $T_{ultconn} = 8,681$  lb/ft (126.7 kN/m)

Ultimate Tensile Strength of Geosynthetic Test Sample  $T_{lot} = 10,635$  lb/ft (155.2 kN/m)

Connection Strength / Sample Strength  $T_{ultconn} / T_{lot} = 0.82$

Short-term Ultimate Connection Strength Reduction Factor<sup>(c)</sup>  $CR_u = 0.82$

### Creep Reduction Factor

75-Year Design  $RF_{cr(75)} = 1.56$

100-Year Design  $RF_{cr(100)} = 1.58$

Durability Reduction Factor<sup>(d)</sup>  $RF_D = 1.15$

### Long-term Connection Strength Reduction Factor

75-Year Design  $CR_{cr(75)} = 0.53$

100-Year Design  $CR_{cr(100)} = 0.52$

### Nominal Long-term Geosynthetic Connection Strength

75-Year Design  $T_{ac(75)} = 4,342$  lb/ft (63.4 kN/m)

100-Year Design  $T_{ac(100)} = 4,287$  lb/ft (62.6 kN/m)

(a) Tested with 3/4 inch (19 mm) clean crushed stone lightly compacted in the vertical core slot in accordance with Redi-Rock International's typical installation recommendations.

(b) Because the geogrid connection is not normal-load dependent and an expression of peak connection for use in design cannot be reliably determined through linear regression, the peak connection results are analyzed as continuous random variables. The average value or sample mean is reported for the test sample as well as a reduction based upon a 95% confidence interval calculated from the Student's t-test for n-1 degrees of freedom.

(c) Recommended  $CR_u$  for design is based on a statistical best-fit analysis of  $T_{ultconn} / T_{lot}$  values across all geogrid types tested.

(d) Recommended value for  $5 < pH < 8$ .  $RF_D$  value of 1.3 recommended for  $4.5 \leq pH \leq 5$  and  $8 \leq pH \leq 9$ .

The information contained in this report has been carefully compiled by Redi-Rock International, LLC as a recommendation of peak connection capacity. It is accurate to the best of our knowledge as of the date of its issue. However, final determination of the suitability of any design information and the appropriateness of this data for a given design purpose is the sole responsibility of the user. No warranty of performance is expressed or implied by the publishing of the foregoing laboratory test results. Issue date: May 12, 2014.

# Geogrid Connection Design Parameters—Miragrid 20XT

Test Methods: ASTM D6638 &amp; NCMA SRWU-1

Test Facility: Bathurst, Clarabut Geotechnical Testing, Inc.

Geogrid Type: Miragrid 20XT

Test Date: December 16, 2011

Block Type: Positive Connection (PC) Block

## CONNECTION STRENGTH TEST DATA<sup>(a)</sup>

Test No.	Normal Load		Peak Connection		Observed Failure
	lb/ft	(kN/m)	lb/ft	(kN/m)	
1	2,608	(38.1)	13,797	(201.4)	Grid Rupture
2	802	(11.7)	13,980	(204.0)	Grid Rupture
3	1,654	(24.1)	13,934	(203.4)	Grid Rupture
4	2,521	(36.8)	14,299	(208.7)	Grid Rupture
5	3,527	(51.5)	12,837	(187.3)	Grid Rupture
6	4,302	(62.8)	13,797	(201.4)	Grid Rupture
7	2,573	(37.6)	14,345	(209.3)	Grid Rupture
8	5,196	(75.8)	13,706	(200.0)	Grid Rupture

Peak Connection<sub>(average)</sub> = 13,837 lb/ft (201.9 kN/m)Peak Connection<sub>(95% confidence level)<sup>(b)</sup></sub> = 13,447 lb/ft (196.2 kN/m)

## CONNECTION STRENGTH

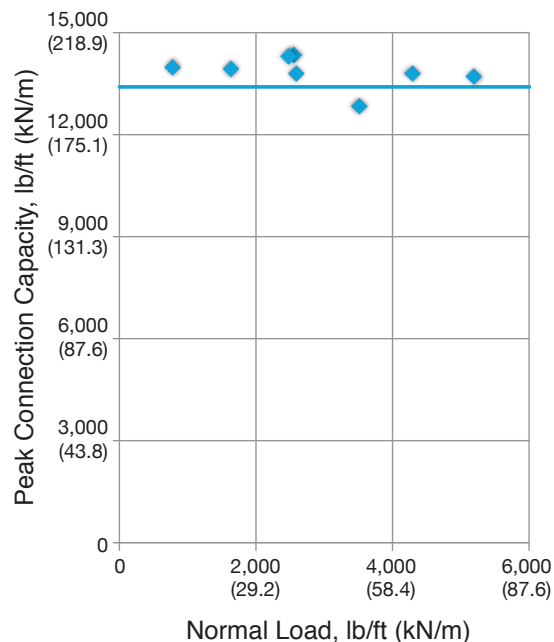

## CONNECTION DESIGN DATA

for use with AASHTO LRFD Bridge Design Specifications, 6th Edition (2012)

Miragrid 20XT Ultimate Tensile Strength (MARV)  $T_{ult} = 13,705$  lb/ft (200.0 kN/m)Ultimate Connection Strength  $T_{ultconn} = 13,447$  lb/ft (196.2 kN/m)Ultimate Tensile Strength of Geosynthetic Test Sample  $T_{lot} = 16,397$  lb/ft (239.3 kN/m)Connection Strength / Sample Strength  $T_{ultconn} / T_{lot} = 0.82$ Short-term Ultimate Connection Strength Reduction Factor<sup>(c)</sup>  $CR_u = 0.80$ 

Creep Reduction Factor

75-Year Design  $RF_{cr(75)} = 1.56$ 100-Year Design  $RF_{cr(100)} = 1.58$ Durability Reduction Factor<sup>(d)</sup>  $RF_D = 1.15$ 

Long-term Connection Strength Reduction Factor

75-Year Design  $CR_{cr(75)} = 0.51$ 100-Year Design  $CR_{cr(100)} = 0.51$ 

Nominal Long-term Geosynthetic Connection Strength

75-Year Design  $T_{ac(75)} = 6,111$  lb/ft (89.2 kN/m)100-Year Design  $T_{ac(100)} = 6,034$  lb/ft (88.1 kN/m)

(a) Tested with 3/4 inch (19 mm) clean crushed stone lightly compacted in the vertical core slot in accordance with Redi-Rock International's typical installation recommendations.

(b) Because the geogrid connection is not normal-load dependent and an expression of peak connection for use in design cannot be reliably determined through linear regression, the peak connection results are analyzed as continuous random variables. The average value or sample mean is reported for the test sample as well as a reduction based upon a 95% confidence interval calculated from the Student's t-test for n-1 degrees of freedom.

(c) Recommended  $CR_u$  for design is based on a statistical best-fit analysis of  $T_{ultconn} / T_{lot}$  values across all geogrid types tested.

(d) Recommended value for  $5 < pH < 8$ .  $RF_D$  value of 1.3 recommended for  $4.5 \leq pH \leq 5$  and  $8 \leq pH \leq 9$ .

The information contained in this report has been carefully compiled by Redi-Rock International, LLC as a recommendation of peak connection capacity. It is accurate to the best of our knowledge as of the date of its issue. However, final determination of the suitability of any design information and the appropriateness of this data for a given design purpose is the sole responsibility of the user. No warranty of performance is expressed or implied by the publishing of the foregoing laboratory test results. Issue date: May 12, 2014.

# Geogrid Connection Design Parameters—Miragrid 24XT

Test Methods: ASTM D6638 &amp; NCMA SRWU-1

Test Facility: Bathurst, Clarabut Geotechnical Testing, Inc.

Geogrid Type: Miragrid 24XT

Test Date: February 29, 2012

Block Type: Positive Connection (PC) Block

## CONNECTION STRENGTH TEST DATA<sup>(a)</sup>

Test No.	Normal Load		Peak Connection		Observed Failure
	lb/ft	(kN/m)	lb/ft	(kN/m)	
1	4,046	(59.0)	20,375	(297.4)	Grid Rupture
2	4,362	(63.7)	22,020	(321.4)	Grid Rupture
3	665	(9.7)	22,568	(329.4)	Grid Rupture
4	2,538	(37.0)	20,832	(304.0)	Grid Rupture
5	1,713	(25.0)	21,746	(317.4)	Grid Rupture
6	5,248	(76.6)	21,837	(318.7)	Block & Grid
7	2,539	(37.1)	19,914	(290.6)	Grid Rupture
8	4,063	(59.3)	21,015	(306.7)	Block Rupture

Peak Connection<sub>(average)</sub> = 21,288 lb/ft (310.7 kN/m)Peak Connection<sub>(95% confidence level)<sup>(b)</sup></sub> = 20,535 lb/ft (299.7 kN/m)

## CONNECTION DESIGN DATA

for use with AASHTO LRFD Bridge Design Specifications, 6th Edition (2012)

Miragrid 24XT Ultimate Tensile Strength (MARV)  $T_{ult} = 27,415$  lb/ft (400.1 kN/m)Ultimate Connection Strength  $T_{ultconn} = 20,535$  lb/ft (299.7 kN/m)Ultimate Tensile Strength of Geosynthetic Test Sample  $T_{lot} = 29,130$  lb/ft (425.1 kN/m)Connection Strength / Sample Strength  $T_{ultconn} / T_{lot} = 0.70$ Short-term Ultimate Connection Strength Reduction Factor<sup>(c)</sup>  $CR_u = 0.70$ 

Creep Reduction Factor

75-Year Design  $RF_{cr(75)} = 1.56$ 100-Year Design  $RF_{cr(100)} = 1.58$ Durability Reduction Factor<sup>(d)</sup>  $RF_D = 1.15$ 

Long-term Connection Strength Reduction Factor

75-Year Design  $CR_{cr(75)} = 0.45$ 100-Year Design  $CR_{cr(100)} = 0.45$ 

Nominal Long-term Geosynthetic Connection Strength

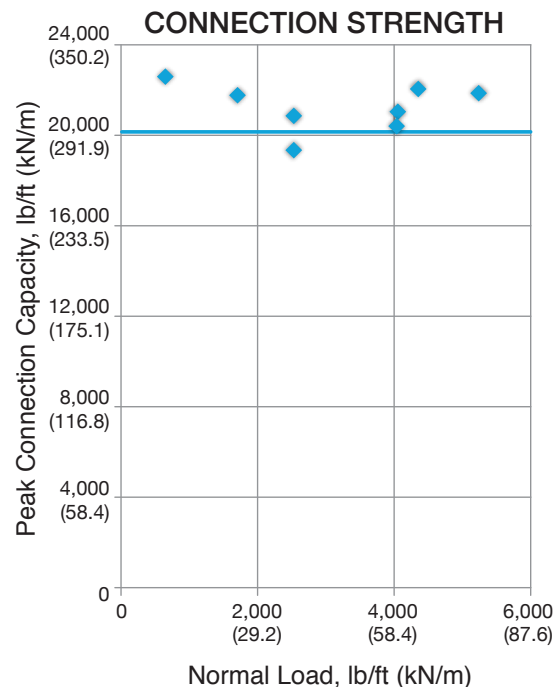
75-Year Design  $T_{ac(75)} = 10,773$  lb/ft (157.2 kN/m)100-Year Design  $T_{ac(100)} = 10,636$  lb/ft (155.2 kN/m)

(a) Tested with 3/4 inch (19 mm) clean crushed stone lightly compacted in the vertical core slot in accordance with Redi-Rock International's typical installation recommendations.

(b) Because the geogrid connection is not normal-load dependent and an expression of peak connection for use in design cannot be reliably determined through linear regression, the peak connection results are analyzed as continuous random variables. The average value or sample mean is reported for the test sample as well as a reduction based upon a 95% confidence interval calculated from the Student's t-test for n-1 degrees of freedom.

(c) Recommended  $CR_u$  for design is based on a statistical best-fit analysis of  $T_{ultconn} / T_{lot}$  values across all geogrid types tested.

(d) Recommended value for  $5 < pH < 8$ .  $RF_D$  value of 1.3 recommended for  $4.5 \leq pH \leq 5$  and  $8 \leq pH \leq 9$ .

The information contained in this report has been carefully compiled by Redi-Rock International, LLC as a recommendation of peak connection capacity. It is accurate to the best of our knowledge as of the date of its issue. However, final determination of the suitability of any design information and the appropriateness of this data for a given design purpose is the sole responsibility of the user. No warranty of performance is expressed or implied by the publishing of the foregoing laboratory test results. Issue date: May 12, 2014.

# Geogrid Packaging, Ordering, and Delivery

Geogrid for Redi-Rock Positive Connection (PC) System retaining walls is provided in 12 inch (305 millimeter) wide strips in 200 feet (61 meters) long rolls. Geogrids approved for use are Mirafi XT manufactured by TenCate Geosynthetics of Pendergrass,

Georgia, USA. The geogrid strips are factory cut to width and are certified for width and strength by TenCate Mirafi. **Other geogrid products or strips that are field cut to width from larger rolls are not allowed.**

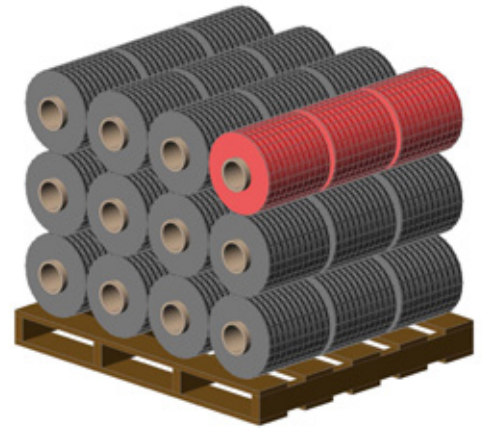

The geogrid is packaged with 3 rolls on each cardboard tube. Total number of rolls that can be placed on a pallet varies with product type.

Geogrid	Rolls Per Pallet	Pallet Weight
5XT	60	743 lb (337 kg)
8XT	48	764 lb (346 kg)
10XT	48	958 lb (434 kg)
20 XT	27	503 lb (228 kg)
24XT	27	1,478 lb (670 kg)

Geogrid strips are available exclusively through the Redi-Rock network of independently-owned and -operated, licensed manufacturers. Contact information for the Redi-Rock manufacturer in your area is available at [redi-rock.com](http://redi-rock.com).

Typically, the geogrid strips are ordered by the pallet. If your project doesn't require a full pallet of geogrid strips, smaller tube quantities may be available from your Redi-Rock manufacturer.

Additionally, custom roll lengths between 150 feet (45 meters) and 250 feet (76 meters) are available in quantities greater than 48 pallets of the same geogrid type. Plan ahead because a minimum 10 week lead time is required for custom lengths.

## GEOGRID ESTIMATING

Geogrid estimating for a project is a simple process:

- Determine the cut length of strips for your different wall sections.
- Roll length / cut length = number of whole strips you can get from each roll of geogrid.
- Total number of required strips / number of strips per roll = total number of rolls you need to order.

The preliminary charts list an approximate length of geogrid for estimating purposes. The example below is for a 21 foot (6.4 meter) tall wall section in 30° soil with no surcharge loads or slopes:

Type	Rolls per linear foot	Rolls per linear meter
5XT	±0.26	±0.85
10XT	±0.30	±1.00

In this example, the geogrid required to build a 100 foot (30.5 meter) long section of wall (26 blocks long) is:

$$100 \times 0.26 = 26 \text{ rolls of 5XT}$$

$$100 \times 0.30 = 30 \text{ rolls of 10XT}$$

*(This information is included with each cross section in the Preliminary Reinforcement Schedule in the MSE Wall section of the DRM.)*

# Minimum Turning Radius

Convex curves can easily be incorporated into a Redi-Rock wall. Redi-Rock blocks are tapered on each side. The smallest radius that can be made with Redi-Rock blocks (without cutting the blocks) occurs when the blocks are placed together with their sides touching. The minimum radius for full-size blocks is 14 feet-6 inches (4.42

meters) from the face of the blocks. A minimum radius of 8 foot-0 inches (2.44 meters) from the face of the blocks can be made if all half blocks are used; however, there will not be a running bond joint between blocks.

Block-to-block setback will cause the radius for each succeeding row to be smaller than the row before. To ensure the minimum radius

of the top row of blocks in a wall, start with the minimum radius and then add 2 inches (51 millimeter) per course for each standard setback block, 10 inches (254 millimeter) per course for each 9 inch (230 millimeter) setback block, and 17 inch (432 millimeter) per course for each planter block in the wall below the top row of blocks.

## MINIMUM RADIUS FOR BOTTOM ROW OF BLOCKS

Number of Courses	Height of Wall	No Planter Blocks		One Row of Planter Blocks	
		Radius From Face of Block	Distance Between Blocks*	Radius From Face of Block	Distance Between Blocks*
1	1'-6" (0.46 m)	14'-6" (4.42 m)	0.13" (3 mm)		
2	3'-0" (0.91 m)	14'-8" (4.47 m)	0.21" (5 mm)		
3	4'-6" (1.37 m)	14'-10" (4.52 m)	0.28" (7 mm)		
4	6'-0" (1.83 m)	15'-0" (4.57 m)	0.36" (9 mm)	16'-3" (4.95 m)	0.88" (22 mm)
5	7'-6" (2.29 m)	15'-2" (4.62 m)	0.43" (11 mm)	16'-5" (5.00 m)	0.94" (24 mm)
6	9'-0" (2.74 m)	15'-4" (4.67 m)	0.50" (13 mm)	16'-7" (5.05 m)	1.00" (25 mm)
7	10'-6" (3.20 m)	15'-5" (4.72 m)	0.57" (15 mm)	16'-9" (5.11 m)	1.06" (27 mm)
8	12'-0" (3.66 m)	15'-8" (4.78 m)	0.63" (16 mm)	16'-11" (5.16 m)	1.09" (28 mm)
9	13'-6" (4.11 m)	15'-10" (4.83 m)	0.70" (18 mm)	17'-1" (5.21 m)	1.12" (29 mm)
10	15'-0" (4.57 m)	16'-0" (4.88 m)	0.76" (19 mm)	17'-3" (5.26 m)	1.19" (30 mm)

\* Distance between blocks is measured at the back of 28 inch (710 millimeter) PC blocks and 24 inch (610 millimeter) behind the form parting line (back edge of face texture) for 41 inch (1030 millimeter) PC Blocks. This distance is intended to be a guide only. Minimum radius is controlling.

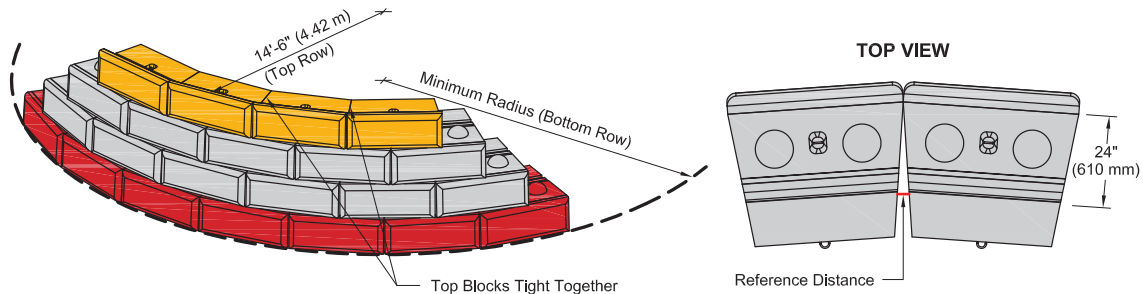

Concave curves may be installed at varying radii. The blocks should be placed tight together to make a smooth curve. Although there is no fixed minimum radius, smaller radii lengths of less than 14'6" (4.42 m) will result in exposing more of the untextured top face of the blocks in the underlying layer.

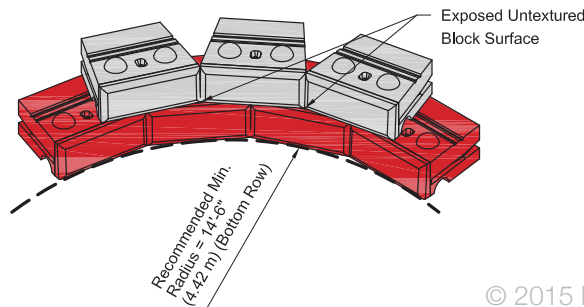



# Positive Connection (PC) Design Guide

Redi-Rock publishes a great resource created especially for engineers who are considering, designing, or reviewing a mechanically stabilized

earth wall utilizing the Redi-Rock PC System. Inside the PC System Design Guide you will find an overview of the system, sample projects,

components, MSEW inputs, and an example problem. This 30 page document is available for immediate download at [redi-rock.com](http://redi-rock.com).

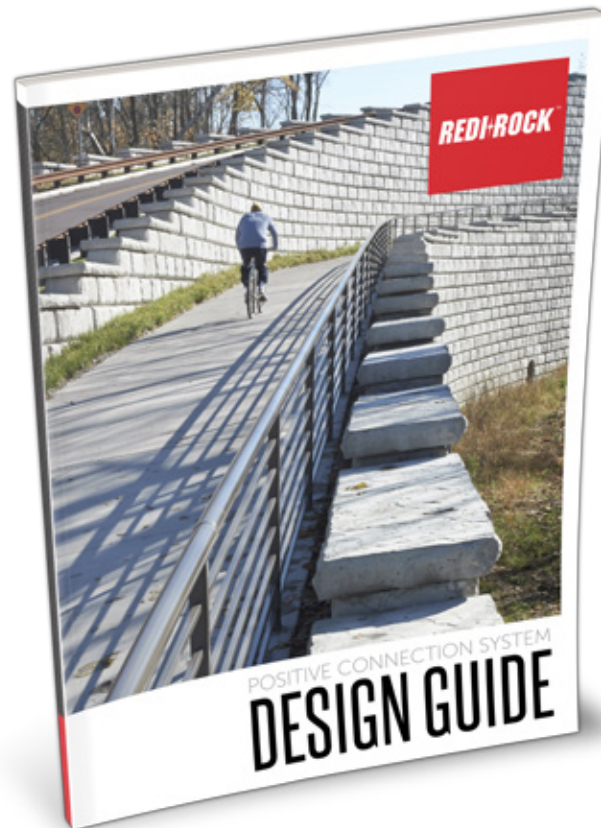

## IN THE PC DESIGN GUIDE, YOU'LL FIND:

- System overview
- Case Studies
- Description of system components
- Recommended connection design parameters
- Recommended MSEW input parameters
- Example problem

# Redi-Rock Wall Analysis Software

Redi-Rock is pleased to offer a sophisticated computer software program for the analysis and design of Redi-Rock gravity retaining walls. Redi-Rock Wall is written by the experts at *Fine Civil Engineering Software* and is tailored exclusively to Redi-Rock retaining wall blocks. Redi-Rock Wall includes a wall analysis module, bearing capacity module, and overall

(global) stability module to evaluate all aspects of a retaining wall.

Redi-Rock Wall was written by engineers, for engineers. It includes the ability to use multiple block widths, setbacks, and unit weights in the same cross section. It will perform both ASD and LRFD calculations with user input safety or load and resistance factors. Multiple soil

layers, loading conditions, and top and bottom of wall geometries can be evaluated. The program will even perform seismic calculations and rapid drawdown calculations. Redi-Rock Wall is available free for immediate download at [redi-rock.com](http://redi-rock.com). Get your copy of Redi-Rock Wall and see what this exciting software can do for you.



## REDI-ROCK WALL OFFERS:

- ASD calculations
- LRFD calculations
- Sliding calculations
- Overturning calculations
- Bearing capacity calculations
- Eccentricity calculations
- Overall stability calculations
- Multiple block widths in the same cross-section
- Multiple setbacks in the same cross-section
- Preloaded and user defined block infill weight
- Preloaded and user defined block-to-block interface shear values
- Multiple soil layers in the same cross-section
- Multiple loading conditions
- Seismic analysis
- Hydrostatic analysis
- Preloaded and user defined top and bottom of wall geometries
- Preloaded and user defined safety factors and load and resistance factors





GRAVITY WALLS

## STANDARD BATTER GRAVITY WALLS

34°   DENSE WELL-GRADED SAND <i>or</i> SAND AND GRAVEL.....	86
30°   FINE TO MEDIUM SAND <i>or</i> SILTY SAND .....	91
28°   SILTY SAND <i>or</i> CLAYEY SAND .....	95
40° OVER 26°   CRUSHED STONE BACKFILL REPLACING SILTY OR CLAYEY SAND.....	99

## IMPORTANT NOTICE

The design specifications for Redi-Rock® blocks suggest maximum installation heights under certain assumed conditions. These wall heights were calculated using the assumed material properties and loading conditions in the *Design Resource Manual* and will vary from location to location depending on the soil properties and terrain. Since soil conditions and topography vary greatly from site to site, an engineering analysis must be performed for each wall installation.

Because Redi-Rock International does not build the blocks or install the wall system, Redi-Rock International does not assume any responsibility regarding structural stability of any particular block or particular wall system. In addition, Redi-Rock International assumes no responsibility in connection with any injury, death, or property damage claim whatsoever whether asserted against a Lessee, Leasor, Purchaser or others, arising out of or attributable to the operation of or products produced with Redi-Rock International equipment.

# Preliminary Height Guide

This preliminary height guide has been prepared showing Redi-Rock walls in a variety of assumed conditions. It is intended to give the specifier an idea of what block types are required and what heights are achievable with Redi-Rock in different applications. A combination of Redi-Rock 28" (710 mm), 41" (1030 mm), and 60" (1520 mm) wide blocks with the standard 5° wall batter are used to provide the most efficient cross-section available in the different conditions.

Several assumptions have been made in preparation of the guide. They are listed in the notes below. If these assumptions do not match the wall section under consideration, block selections and achievable heights may vary from the sections shown in this guide. All wall sections for construction must be designed by a registered Professional Engineer using the actual conditions of the site.

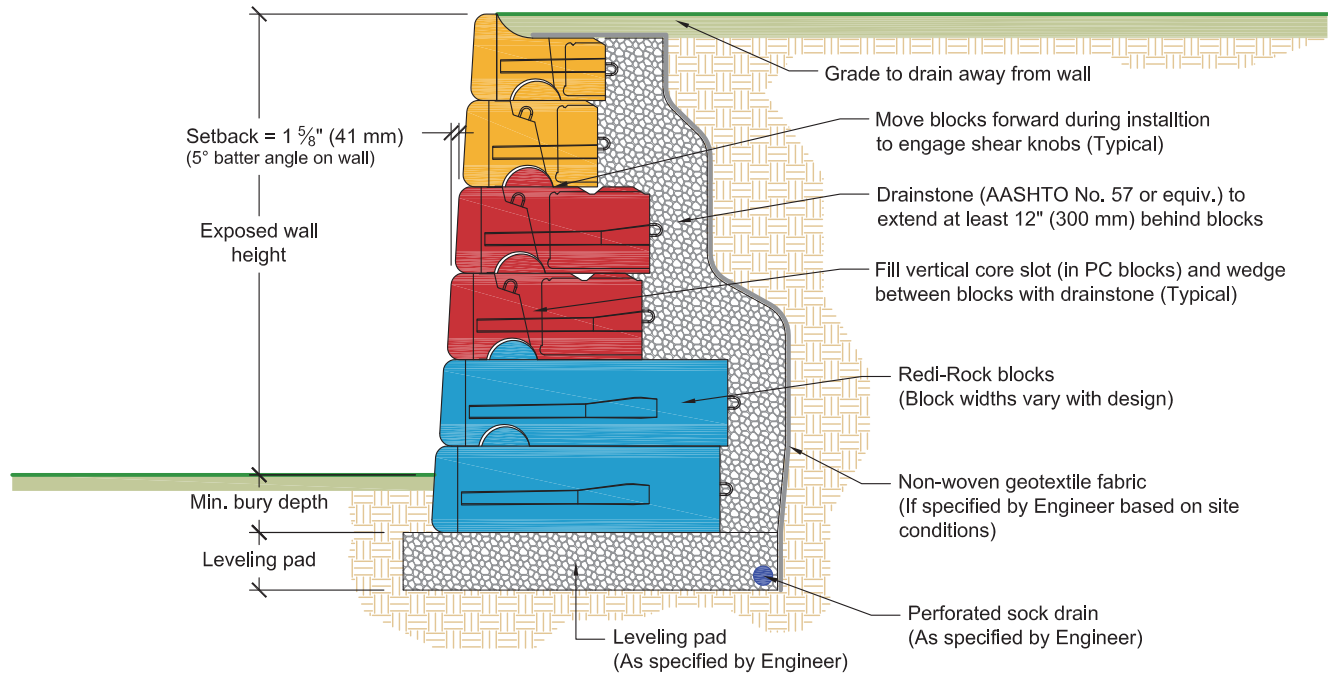

## Notes:

This preliminary guide has been prepared for three different soil types, three different load conditions, and with three different width blocks to give an indication of the performance of Redi-Rock walls. A wall batter of 5° was used for this preliminary guide. **Redi-Rock walls are not limited to these conditions.** Specific wall sections can incorporate different block setbacks and can be designed for different soil and loading conditions.

Unit weight of soil is assumed to be 120 lb/ft<sup>3</sup> (18.85 kN/m<sup>3</sup>) or 130 lb/ft<sup>3</sup> (20.4 kN/m<sup>3</sup>) as noted for each section of this preliminary guide.

Minimum factors of safety are 1.5 for sliding, 1.5 for overturning, 2.0 for bearing capacity, and 1.3 for global stability. Other factors of safety will result in changes from the wall heights and block selections shown in this guide.

No seismic or hydrostatic loads were included in this preliminary guide.

Ledgestone texture PC blocks were used to prepare this preliminary guide. Wall heights and block selections for other textures and blocks may vary.

A solid block without the vertical core slot was used for the bottom block on all wall sections shown.

Independent barrier design at the top of the wall must be performed for site specific conditions. Barrier requirements may result in changes to available wall heights and block selections from those shown in this guide.

**Wall stability needs to be verified in the final design for site-specific conditions.**

The wall design shall address both internal and external drainage and shall be evaluated by the Professional Engineer who is responsible for the final wall design.

Backfill material to be compacted to 90% modified proctor density (ASTM D1557).

All Redi-Rock International Wall System Specifications and installation recommendations should be followed.

Construction oversight should be provided on all walls to ensure proper construction according to your detailed design drawings.

Not tall enough? Greater wall heights are achievable with select backfill, increased wall batter, and/or mechanically stabilized earth Redi-Rock walls.

Redi-Rock products are manufactured by independently owned, licensed manufacturers. Product offerings will vary between manufacturers. Contact your local manufacturer to determine what products are available for your job.

These block selection and height guides were prepared by Redi-Rock International for estimating and conceptual design purposes only. All information is believed to be true and accurate; however, Redi-Rock International assumes no responsibility for the use of these preliminary guides for actual construction. Determination of the suitability of each preliminary guide is the sole responsibility of the user. **Final designs for construction purposes must be performed by a registered Professional Engineer, using the actual conditions of the proposed site.**

# Preliminary Height Guide

## $\phi = 34^\circ$ | DENSE WELL-GRADED SAND or SAND AND GRAVEL

Standard batter gravity walls	SECTION 1 OF 4
Assumed retained and foundation soils for this Section	SW, GW
Internal angle of friction	$\phi = 34^\circ$
Unit weight	$\gamma = 130 \text{ lb / ft}^3$ (20.4 kN / m <sup>3</sup> )
Cohesion	$c = 0 \text{ lb / ft}^2$ (0 kPa)

**LOAD CONDITION A** | NO LIVE LOAD SURFACE, NO BACK SLOPE, NO TOE SLOPE .....87

**LOAD CONDITION B** | 250 lb/ft<sup>2</sup> (12 kPa) LIVE LOAD SURCHARGE, NO BACK SLOPE, NO TOE SLOPE .....89

**LOAD CONDITION C** | 1 : 2.5 BACK SLOPE, NO TOE SLOPE, NO LIVE LOAD SURCHARGE.....90

# Preliminary Height Guide

$\phi = 34^\circ$  | DENSE WELL-GRADED SAND or SAND AND GRAVEL

**LOAD CONDITION A** | NO LIVE LOAD SURCHARGE, NO BACK SLOPE, NO TOE SLOPE

**2 BLOCK HIGH SECTION**

(2) 28" (710 mm) Blocks

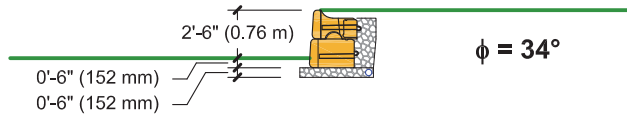

**3 BLOCK HIGH SECTION**

(3) 28" (710 mm) Blocks

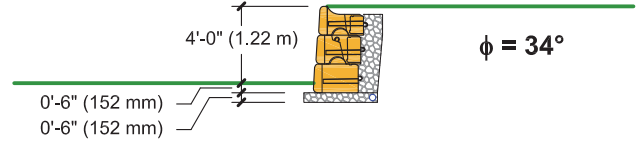

**4 BLOCK HIGH SECTION**

(4) 28" (710 mm) Blocks

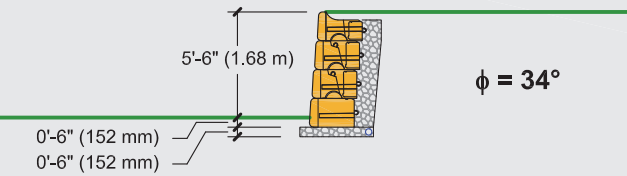

**5 BLOCK HIGH SECTION**

(5) 28" (710 mm) Blocks

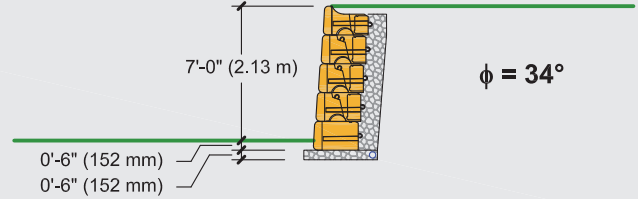

**6 BLOCK HIGH SECTION**

(4) 28" (710 mm) Blocks  
(2) 41" (1030 mm) Blocks

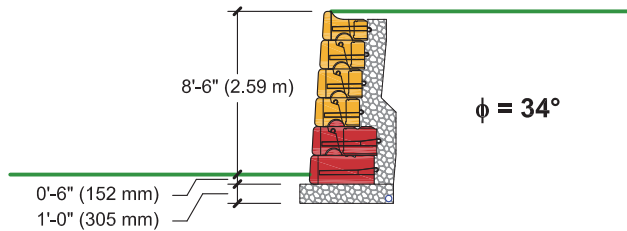

**7 BLOCK HIGH SECTION**

(3) 28" (710 mm) Blocks  
(4) 41" (1030 mm) Blocks

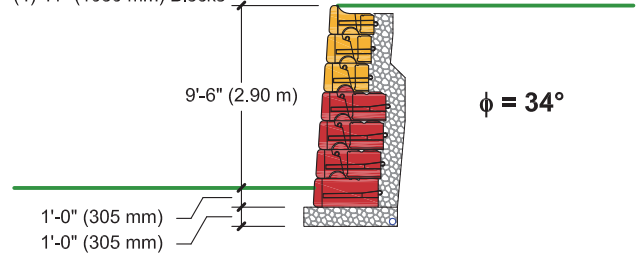

**8 BLOCK HIGH SECTION**

(3) 28" (710 mm) Blocks  
(4) 41" (1030 mm) Blocks  
(1) 60" (1520 mm) Block

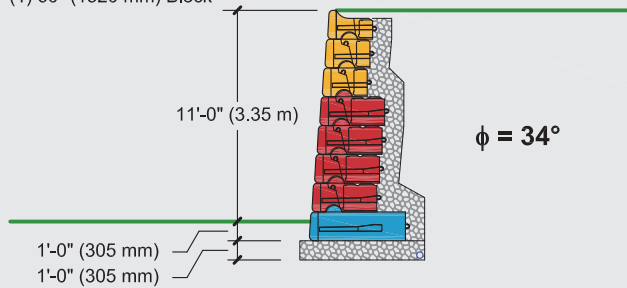

**9 BLOCK HIGH SECTION**

(3) 28" (710 mm) Blocks  
(4) 41" (1030 mm) Blocks  
(2) 60" (1520 mm) Blocks

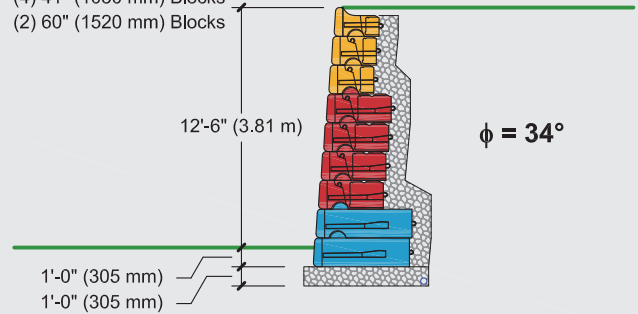

**Legend:**

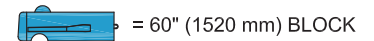
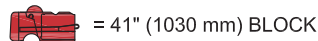
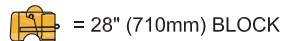

**SEE NOTES AND RECOMMENDED DETAILS AT START OF PRELIMINARY HEIGHT GUIDE.**

# Preliminary Height Guide

$\phi = 34^\circ$  | DENSE WELL-GRADED SAND or SAND AND GRAVEL

**LOAD CONDITION A** | NO LIVE LOAD SURCHARGE, NO BACK SLOPE, NO TOE SLOPE

**10 BLOCK HIGH SECTION**

- (3) 28" (710 mm) Blocks
- (4) 41" (1030 mm) Blocks
- (3) 60" (1520 mm) Blocks

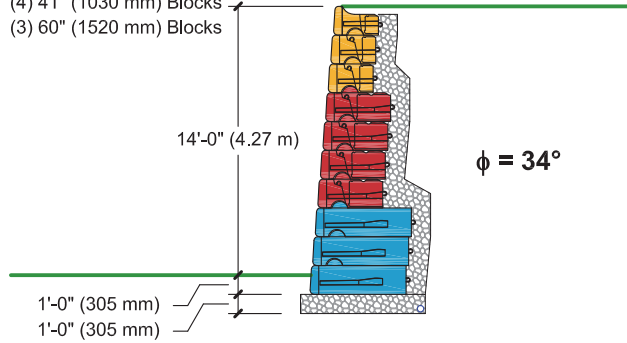



**WANT TO DO MORE? REDI-ROCK WALL ALLOWS YOU TO:**

- Incorporate one or more rows of Planter blocks.
- Incorporate one or more rows of 9" (230 mm) Setback blocks.
- Use Limestone or Cobblestone face blocks.
- Use a different infill stone.
- Evaluate an expanded range of soils or loading conditions.
- Include seismic loads.
- Include water (hydrostatic loads).

[Download the software at redi-rock.com](http://redi-rock.com)

**Legend:**

 = 28" (710mm) BLOCK

 = 41" (1030 mm) BLOCK

 = 60" (1520 mm) BLOCK

**SEE NOTES AND RECOMMENDED DETAILS AT START OF PRELIMINARY HEIGHT GUIDE.**

# Preliminary Height Guide

$\phi = 34^\circ$  | DENSE WELL-GRADED SAND or SAND AND GRAVEL

**LOAD CONDITION B** | 250 lb/ft<sup>2</sup> (12 kPa) LIVE LOAD SURCHARGE, NO BACK SLOPE, NO TOE SLOPE

### 2 BLOCK HIGH SECTION

- (1) 28" (710 mm) Block
- (1) 41" (1030 mm) Block

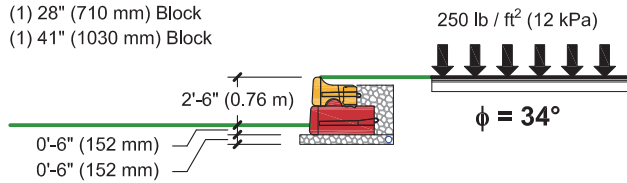

### 3 BLOCK HIGH SECTION

- (1) 28" (710 mm) Block
- (2) 41" (1030 mm) Blocks

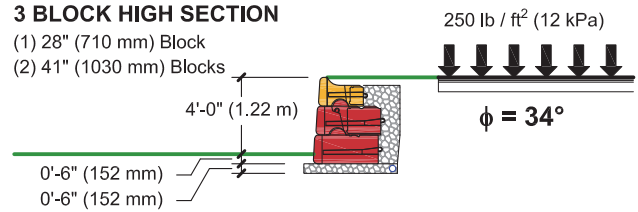

### 4 BLOCK HIGH SECTION

- (1) 28" (710 mm) Block
- (3) 41" (1030 mm) Blocks

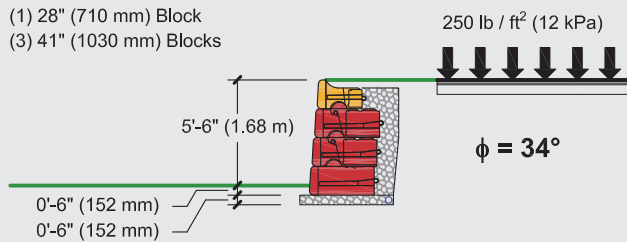

### 5 BLOCK HIGH SECTION

- (1) 28" (710 mm) Block
- (4) 41" (1030 mm) Blocks

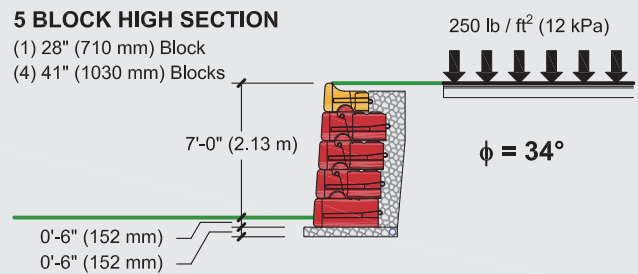

### 6 BLOCK HIGH SECTION

- (1) 28" (710 mm) Block
- (4) 41" (1030 mm) Blocks
- (1) 60" (1520 mm) Block

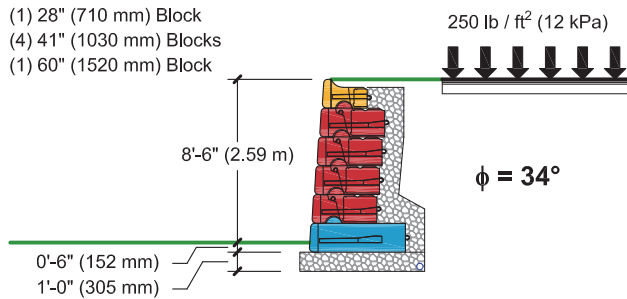

### 7 BLOCK HIGH SECTION

- (1) 28" (710 mm) Block
- (4) 41" (1030 mm) Blocks
- (2) 60" (1520 mm) Blocks

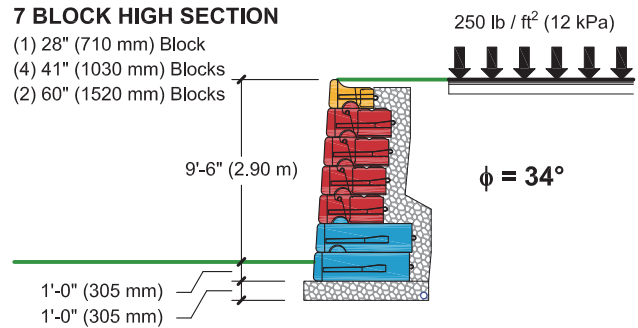

### 8 BLOCK HIGH SECTION

- (1) 28" (710 mm) Block
- (4) 41" (1030 mm) Blocks
- (3) 60" (1520 mm) Blocks

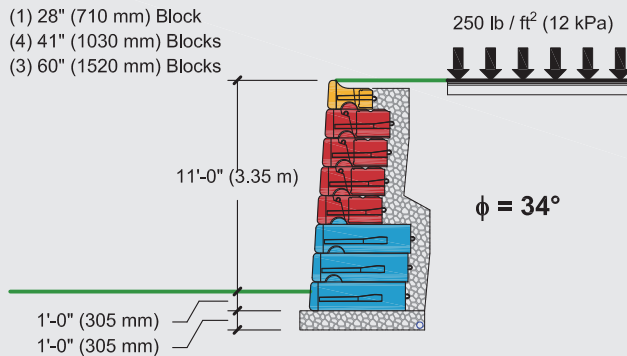

### Legend:

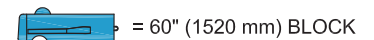
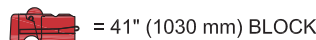
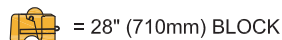

**SEE NOTES AND RECOMMENDED DETAILS AT START OF PRELIMINARY HEIGHT GUIDE.**

# Preliminary Height Guide

$\phi = 34^\circ$  | DENSE WELL-GRADED SAND or SAND AND GRAVEL

**LOAD CONDITION C** | 1 : 2.5 BACK SLOPE, NO TOE SLOPE, NO LIVE LOAD SURCHARGE

### 2 BLOCK HIGH SECTION

(2) 28" (710 mm) Blocks

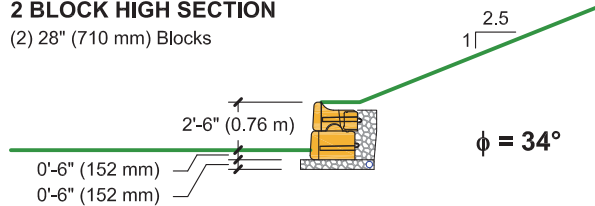

### 3 BLOCK HIGH SECTION

(3) 28" (710 mm) Blocks

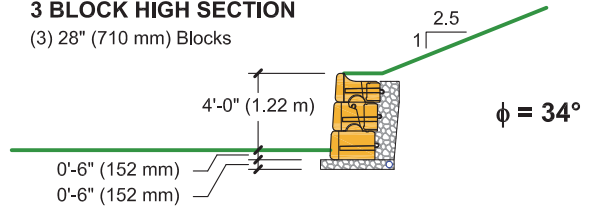

### 4 BLOCK HIGH SECTION

(2) 28" (710 mm) Blocks  
(2) 41" (1030 mm) Blocks

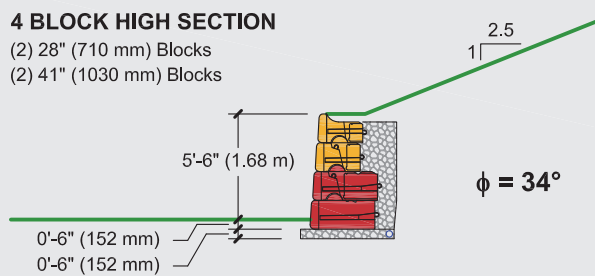

### 5 BLOCK HIGH SECTION

(2) 28" (710 mm) Blocks  
(3) 41" (1030 mm) Blocks

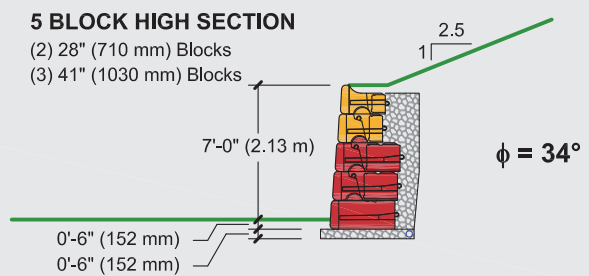

### 6 BLOCK HIGH SECTION

(2) 28" (710 mm) Blocks  
(3) 41" (1030 mm) Blocks  
(1) 60" (1520 mm) Block

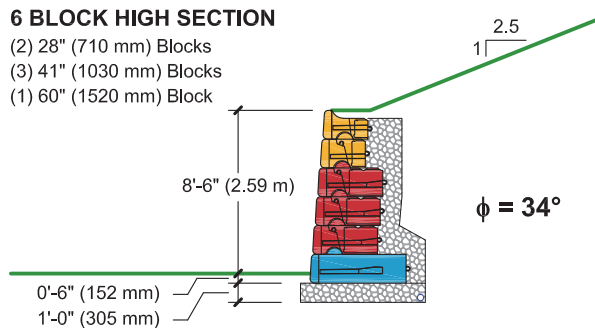

### 7 BLOCK HIGH SECTION

(2) 28" (710 mm) Blocks  
(3) 41" (1030 mm) Blocks  
(2) 60" (1520 mm) Blocks

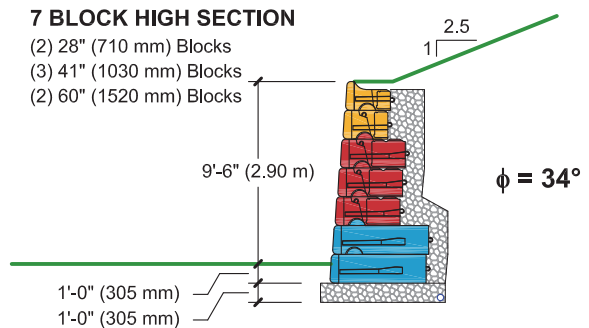

### 8 BLOCK HIGH SECTION

(2) 28" (710 mm) Blocks  
(2) 41" (1030 mm) Blocks  
(4) 60" (1520 mm) Blocks

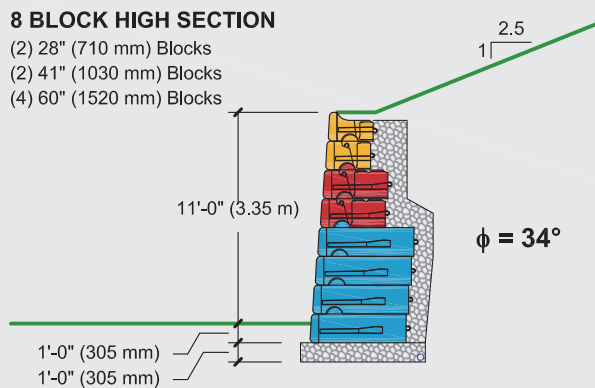



 **WANT TO DO MORE? REDI-ROCK WALL ALLOWS YOU TO:**

- Incorporate one or more rows of Planter blocks.
- Incorporate one or more rows of 9" (230 mm) Setback blocks.
- Use Limestone or Cobblestone face blocks.
- Use a different infill stone.
- Evaluate an expanded range of soils or loading conditions.
- Include seismic loads.
- Include water (hydrostatic loads).

[Download the software at redi-rock.com](http://redi-rock.com)

### Legend:

 = 28" (710mm) BLOCK

 = 41" (1030 mm) BLOCK

 = 60" (1520 mm) BLOCK

**SEE NOTES AND RECOMMENDED DETAILS AT START OF PRELIMINARY HEIGHT GUIDE.**

# Preliminary Height Guide

$\phi = 30^\circ$  | FINE TO MEDIUM SAND or SILTY SAND

Standard batter gravity walls	SECTION 2 OF 4
Assumed retained and foundation soils for this Section	SW, SP, SM
Internal angle of friction	$\phi = 30^\circ$
Unit weight	$\gamma = 120 \text{ lb / ft}^3$ (18.8 kN / m <sup>3</sup> )
Cohesion	$c = 0 \text{ lb / ft}^2$ (0 kPa)

<b>LOAD CONDITION A</b>   NO LIVE LOAD SURFACE, NO BACK SLOPE, NO TOE SLOPE .....	92
<b>LOAD CONDITION B</b>   250 lb/ft <sup>2</sup> (12 kPa) LIVE LOAD SURCHARGE, NO BACK SLOPE, NO TOE SLOPE .....	93
<b>LOAD CONDITION C</b>   1 : 2.5 BACK SLOPE, NO TOE SLOPE, NO LIVE LOAD SURCHARGE.....	94

# Preliminary Height Guide

$\phi = 30^\circ$  | FINE TO MEDIUM SAND or SILTY SAND

**LOAD CONDITION A** | NO LIVE LOAD SURCHARGE, NO BACK SLOPE, NO TOE SLOPE

### 2 BLOCK HIGH SECTION

(2) 28" (710 mm) Blocks

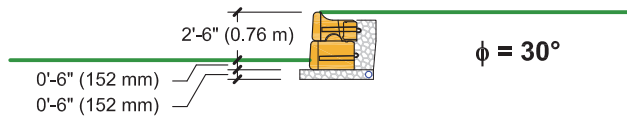

### 3 BLOCK HIGH SECTION

(3) 28" (710 mm) Blocks

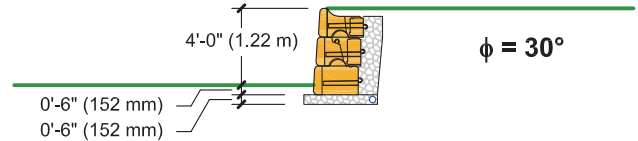

### 4 BLOCK HIGH SECTION

(4) 28" (710 mm) Blocks

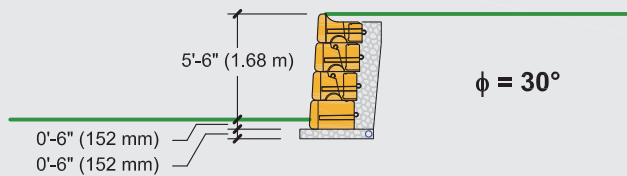

### 5 BLOCK HIGH SECTION

(4) 28" (710 mm) Blocks

(1) 41" (1030 mm) Block

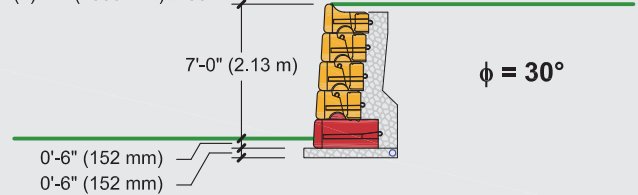

### 6 BLOCK HIGH SECTION

(4) 28" (710 mm) Blocks

(2) 41" (1030 mm) Blocks

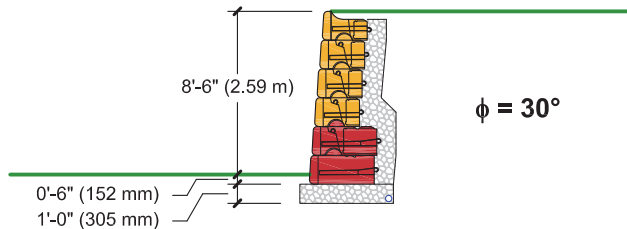

### 7 BLOCK HIGH SECTION

(3) 28" (710 mm) Blocks

(4) 41" (1030 mm) Blocks

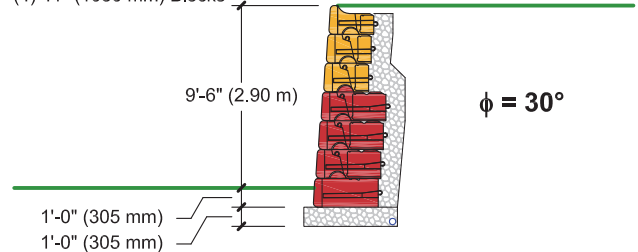

### 8 BLOCK HIGH SECTION

(3) 28" (710 mm) Blocks

(4) 41" (1030 mm) Blocks

(1) 60" (1520 mm) Block

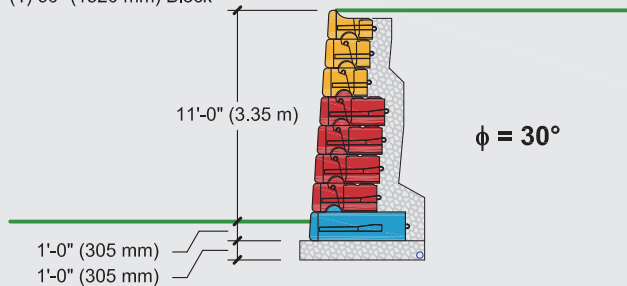

### 9 BLOCK HIGH SECTION

(3) 28" (710 mm) Blocks

(4) 41" (1030 mm) Blocks

(2) 60" (1520 mm) Blocks

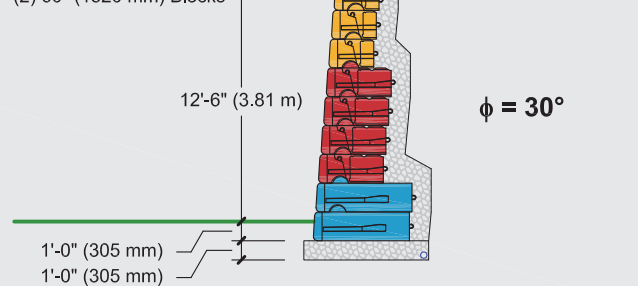

### Legend:

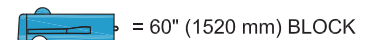
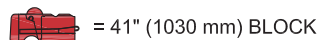
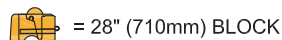

**SEE NOTES AND RECOMMENDED DETAILS AT START OF PRELIMINARY HEIGHT GUIDE.**

# Preliminary Height Guide

$\phi = 30^\circ$  | FINE TO MEDIUM SAND or SILTY SAND

**LOAD CONDITION B** | 250 lb/ft<sup>2</sup> (12 kPa) LIVE LOAD SURCHARGE, NO BACK SLOPE, NO TOE SLOPE

### 2 BLOCK HIGH SECTION

- (1) 28" (710 mm) Block
- (1) 41" (1030 mm) Block

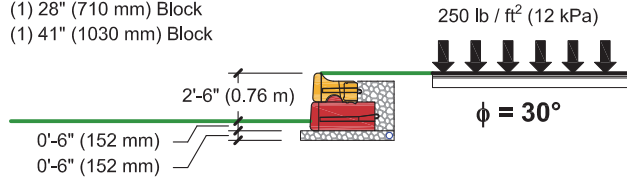

### 3 BLOCK HIGH SECTION

- (1) 28" (710 mm) Block
- (2) 41" (1030 mm) Blocks

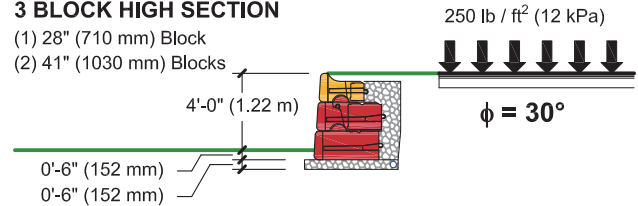

### 4 BLOCK HIGH SECTION

- (1) 28" (710 mm) Block
- (3) 41" (1030 mm) Blocks

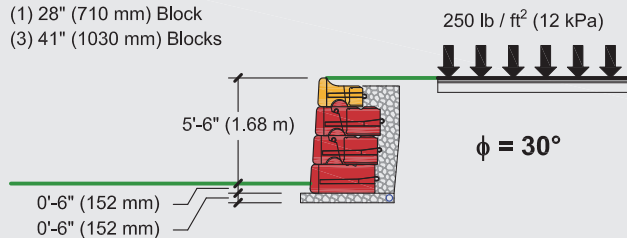

### 5 BLOCK HIGH SECTION

- (1) 28" (710 mm) Block
- (3) 41" (1030 mm) Blocks
- (1) 60" (1520 mm) Block

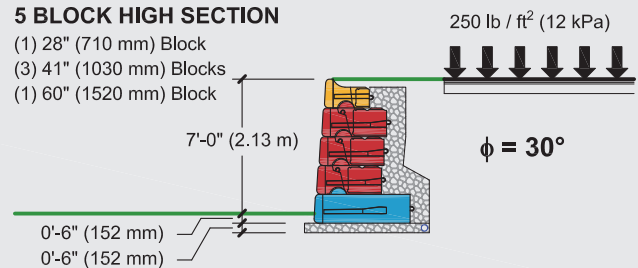

### 6 BLOCK HIGH SECTION

- (1) 28" (710 mm) Block
- (3) 41" (1030 mm) Blocks
- (2) 60" (1520 mm) Blocks

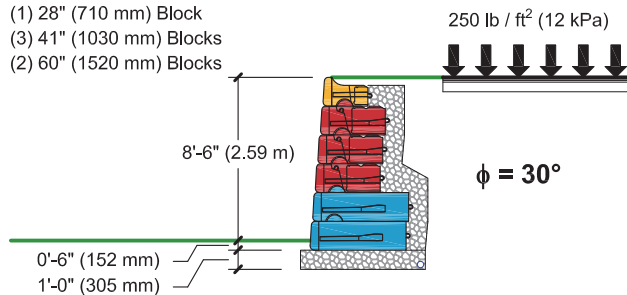

### 7 BLOCK HIGH SECTION

- (1) 28" (710 mm) Block
- (3) 41" (1030 mm) Blocks
- (3) 60" (1520 mm) Blocks

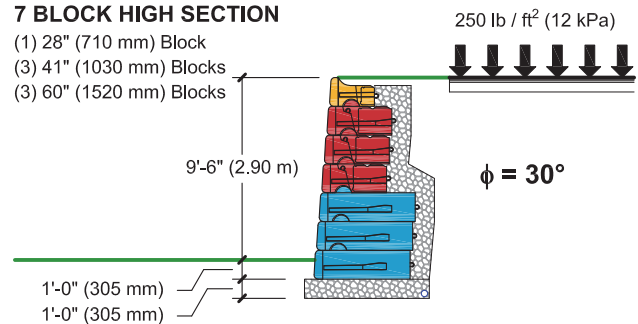



**WANT TO DO MORE? REDI-ROCK WALL ALLOWS YOU TO:**

- Incorporate one or more rows of Planter blocks.
- Incorporate one or more rows of 9" (230 mm) Setback blocks.
- Use Limestone or Cobblestone face blocks.
- Use a different infill stone.
- Evaluate an expanded range of soils or loading conditions.
- Include seismic loads.
- Include water (hydrostatic loads).

[Download the software at redi-rock.com](http://redi-rock.com)

### Legend:

 = 28" (710mm) BLOCK

 = 41" (1030 mm) BLOCK

 = 60" (1520 mm) BLOCK

**SEE NOTES AND RECOMMENDED DETAILS AT START OF PRELIMINARY HEIGHT GUIDE.**

# Preliminary Height Guide

$\phi = 30^\circ$  | FINE TO MEDIUM SAND or SILTY SAND

**LOAD CONDITION C** | 1 : 2.5 BACK SLOPE, NO TOE SLOPE, NO LIVE LOAD SURCHARGE

### 2 BLOCK HIGH SECTION

(2) 28" (710 mm) Blocks

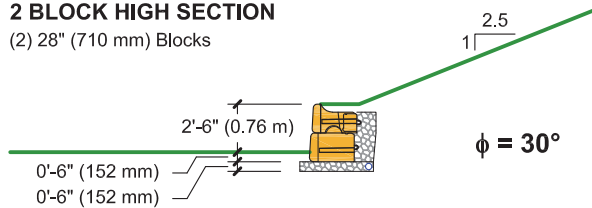

### 3 BLOCK HIGH SECTION

(2) 28" (710 mm) Blocks  
(1) 41" (1030 mm) Block

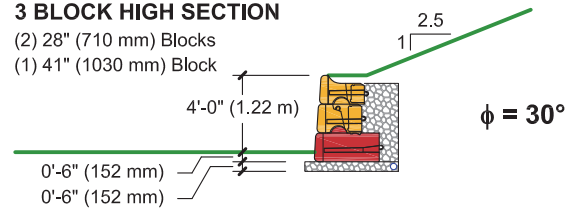

### 4 BLOCK HIGH SECTION

(2) 28" (710 mm) Blocks  
(1) 41" (1030 mm) Block  
(1) 60" (1520 mm) Block

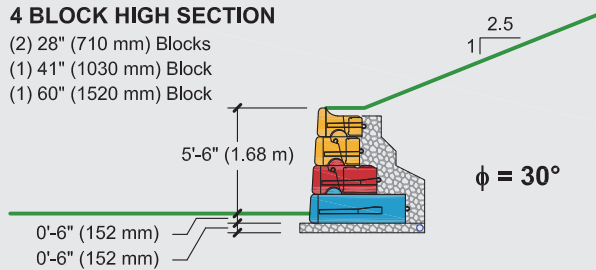

### 5 BLOCK HIGH SECTION

(2) 28" (710 mm) Blocks  
(2) 41" (1030 mm) Blocks  
(1) 60" (1520 mm) Block

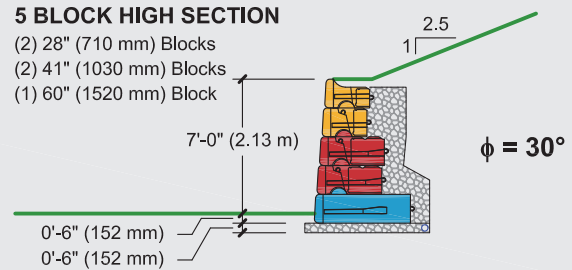

**WANT TO DO MORE? REDI-ROCK WALL ALLOWS YOU TO:**

- Incorporate one or more rows of Planter blocks.
- Incorporate one or more rows of 9" (230 mm) Setback blocks.
- Use Limestone or Cobblestone face blocks.
- Use a different infill stone.
- Evaluate an expanded range of soils or loading conditions.
- Include seismic loads.
- Include water (hydrostatic loads).

[Download the software at redi-rock.com](http://redi-rock.com)

### Legend:



= 28" (710mm) BLOCK



= 41" (1030 mm) BLOCK



= 60" (1520 mm) BLOCK

**SEE NOTES AND RECOMMENDED DETAILS AT START OF PRELIMINARY HEIGHT GUIDE.**

# Preliminary Height Guide

## $\phi = 28^\circ$ | SILTY SAND or CLAYEY SAND

Standard batter gravity walls	SECTION 3 OF 4
Assumed retained and foundation soils for this Section	SM, SC
Internal angle of friction	$\phi = 28^\circ$
Unit weight	$\gamma = 120 \text{ lb / ft}^3$ (18.8 kN / m <sup>3</sup> )
Cohesion	$c = 0 \text{ lb / ft}^2$ (0 kPa)

<b>LOAD CONDITION A</b>   NO LIVE LOAD SURFACE, NO BACK SLOPE, NO TOE SLOPE .....	96
<b>LOAD CONDITION B</b>   250 lb/ft <sup>2</sup> (12 kPa) LIVE LOAD SURCHARGE, NO BACK SLOPE, NO TOE SLOPE .....	97
<b>LOAD CONDITION C</b>   1 : 2.5 BACK SLOPE, NO TOE SLOPE, NO LIVE LOAD SURCHARGE.....	98

# Preliminary Height Guide

$\phi = 28^\circ$  | SILTY SAND or CLAYEY SAND

**LOAD CONDITION A** | NO LIVE LOAD SURCHARGE, NO BACK SLOPE, NO TOE SLOPE

## 2 BLOCK HIGH SECTION

(2) 28" (710 mm) Blocks

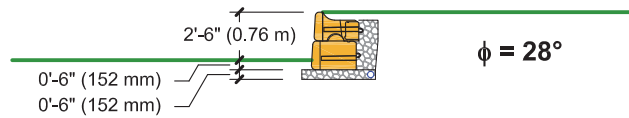

## 3 BLOCK HIGH SECTION

(3) 28" (710 mm) Blocks

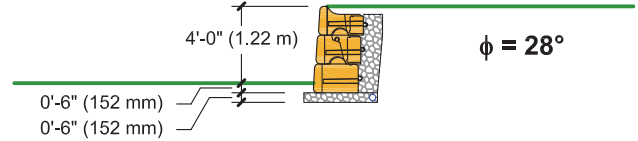

## 4 BLOCK HIGH SECTION

(3) 28" (710 mm) Blocks  
(1) 41" (1030 mm) Block

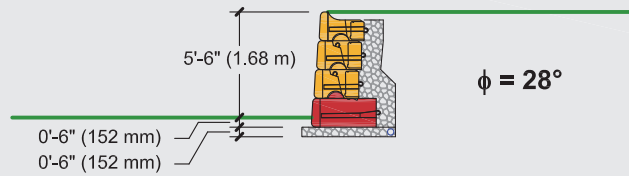

## 5 BLOCK HIGH SECTION

(3) 28" (710 mm) Blocks  
(2) 41" (1030 mm) Blocks

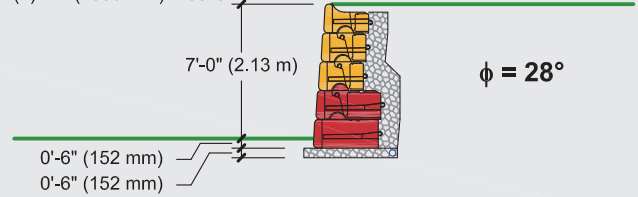

## 6 BLOCK HIGH SECTION

(3) 28" (710 mm) Blocks  
(2) 41" (1030 mm) Blocks  
(1) 60" (1520 mm) Block

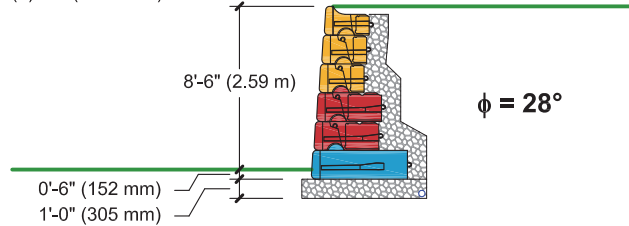

## 7 BLOCK HIGH SECTION

(3) 28" (710 mm) Blocks  
(2) 41" (1030 mm) Blocks  
(2) 60" (1520 mm) Blocks

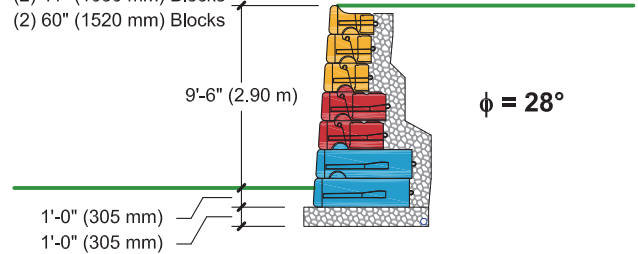

### Legend:

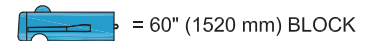
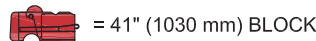
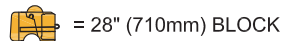

**SEE NOTES AND RECOMMENDED DETAILS AT START OF PRELIMINARY HEIGHT GUIDE.**

# Preliminary Height Guide

$\phi = 28^\circ$  | SILTY SAND or CLAYEY SAND

**LOAD CONDITION B** | 250 lb/ft<sup>2</sup> (12 kPa) LIVE LOAD SURCHARGE, NO BACK SLOPE, NO TOE SLOPE

## 2 BLOCK HIGH SECTION

- (1) 28" (710 mm) Block
- (1) 41" (1030 mm) Block

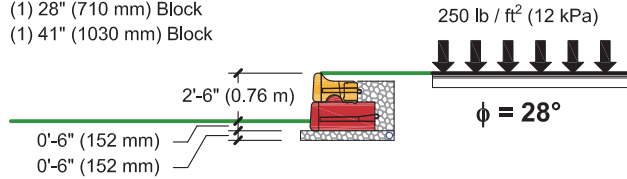

## 3 BLOCK HIGH SECTION

- (1) 28" (710 mm) Block
- (2) 41" (1030 mm) Blocks

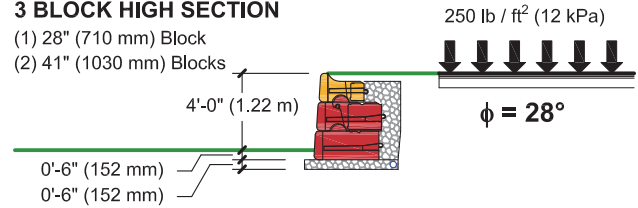

## 4 BLOCK HIGH SECTION

- (1) 28" (710 mm) Block
- (2) 41" (1030 mm) Blocks
- (1) 60" (1520 mm) Block

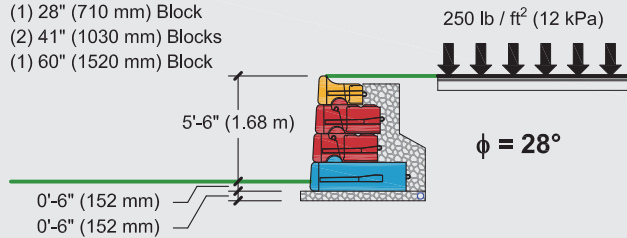

## 5 BLOCK HIGH SECTION

- (1) 28" (710 mm) Block
- (2) 41" (1030 mm) Blocks
- (2) 60" (1520 mm) Blocks

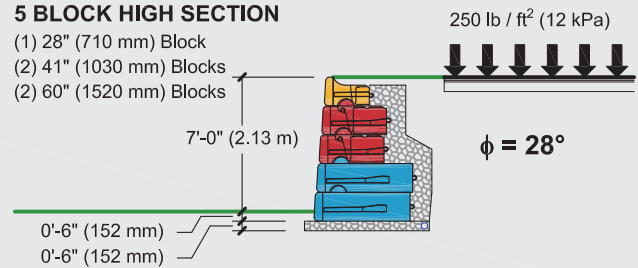

**WANT TO DO MORE? REDI-ROCK WALL ALLOWS YOU TO:**

- Incorporate one or more rows of Planter blocks.
- Incorporate one or more rows of 9" (230 mm) Setback blocks.
- Use Limestone or Cobblestone face blocks.
- Use a different infill stone.
- Evaluate an expanded range of soils or loading conditions.
- Include seismic loads.
- Include water (hydrostatic loads).

[Download the software at redi-rock.com](http://redi-rock.com)

### Legend:



= 28" (710mm) BLOCK



= 41" (1030 mm) BLOCK



= 60" (1520 mm) BLOCK

**SEE NOTES AND RECOMMENDED DETAILS AT START OF PRELIMINARY HEIGHT GUIDE.**

# Preliminary Height Guide

$\phi = 28^\circ$  | SILTY SAND or CLAYEY SAND

**LOAD CONDITION C** | 1 : 2.5 BACK SLOPE, NO TOE SLOPE, NO LIVE LOAD SURCHARGE

## 2 BLOCK HIGH SECTION

- (1) 28" (710 mm) Block
- (1) 41" (1030 mm) Block

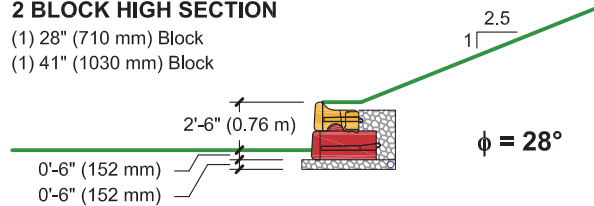

## 3 BLOCK HIGH SECTION

- (1) 28" (710 mm) Block
- (1) 41" (1030 mm) Block
- (1) 60" (1520 mm) Block

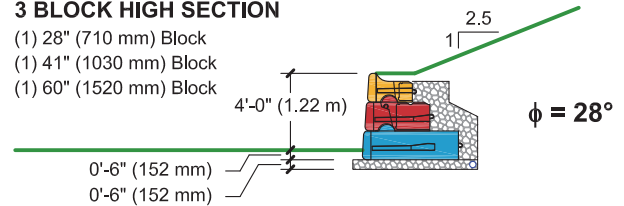

## 4 BLOCK HIGH SECTION

- (1) 28" (710 mm) Blocks
- (1) 41" (1030 mm) Block
- (2) 60" (1520 mm) Blocks

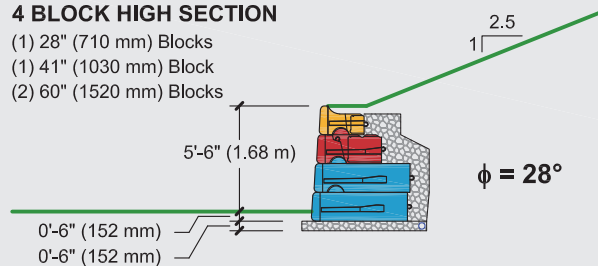



### WANT TO DO MORE? REDI-ROCK WALL ALLOWS YOU TO:

- Incorporate one or more rows of Planter blocks.
- Incorporate one or more rows of 9" (230 mm) Setback blocks.
- Use Limestone or Cobblestone face blocks.
- Use a different infill stone.
- Evaluate an expanded range of soils or loading conditions.
- Include seismic loads.
- Include water (hydrostatic loads).

[Download the software at redi-rock.com](http://redi-rock.com)

### Legend:

 = 28" (710mm) BLOCK

 = 41" (1030 mm) BLOCK

 = 60" (1520 mm) BLOCK

**SEE NOTES AND RECOMMENDED DETAILS AT START OF PRELIMINARY HEIGHT GUIDE.**

# Preliminary Height Guide

**$\phi = 40^\circ$  over  $26^\circ$  | CRUSHED STONE BACKFILL REPLACING SILTY or CLAYEY SAND**

Standard batter gravity walls	SECTION 4 OF 4
Assumed select backfill / retained soil for this Section *	GW, GP
Internal angle of friction	$\phi = 40^\circ$
Unit weight	$\gamma = 130 \text{ lb / ft}^3$ (20.4 kN / m <sup>3</sup> )
Cohesion	$c = 0 \text{ lb / ft}^2$ (0 kPa)
Assumed native / foundation soil for this Section	SM, SC
Internal angle of friction	$\phi = 26^\circ$
Unit weight	$\gamma = 120 \text{ lb / ft}^3$ (18.8 kN / m <sup>3</sup> )
Cohesion	$c = 0 \text{ lb / ft}^2$ (0 kPa)

\* This analysis assumes native material is removed to a 1 on 1 slope or flatter from the back of the proposed retaining wall blocks and replaced with compacted crushed stone.

**LOAD CONDITION A** | NO LIVE LOAD SURFACE, NO BACK SLOPE, NO TOE SLOPE.....100

**LOAD CONDITION B** | 250 lb/ft<sup>2</sup> (12 kPa) LIVE LOAD SURCHARGE, NO BACK SLOPE, NO TOE SLOPE.....102

**LOAD CONDITION C** | 1 : 2.5 BACK SLOPE, NO TOE SLOPE, NO LIVE LOAD SURCHARGE .....103

# Preliminary Height Guide

$\phi = 40^\circ$  over  $26^\circ$  | CRUSHED STONE BACKFILL REPLACING SILTY or CLAYEY SAND

**LOAD CONDITION A** | NO LIVE LOAD SURCHARGE, NO BACK SLOPE, NO TOE SLOPE

### 2 BLOCK HIGH SECTION

(2) 28" (710 mm) Blocks

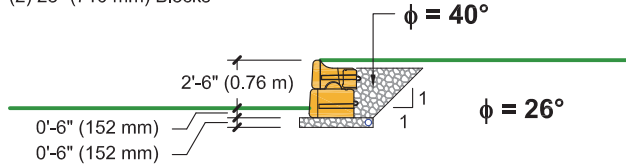

### 3 BLOCK HIGH SECTION

(3) 28" (710 mm) Blocks

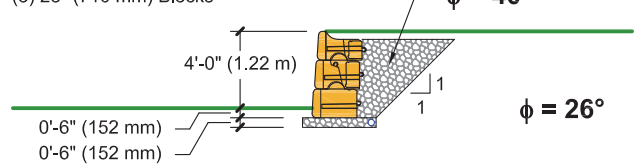

### 4 BLOCK HIGH SECTION

(4) 28" (710 mm) Blocks

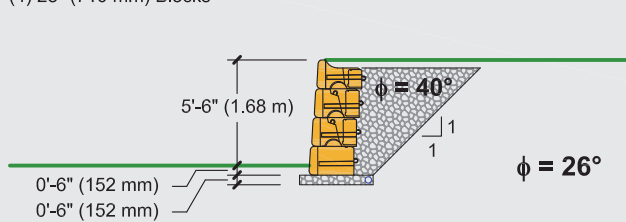

### 5 BLOCK HIGH SECTION

(4) 28" (710 mm) Blocks

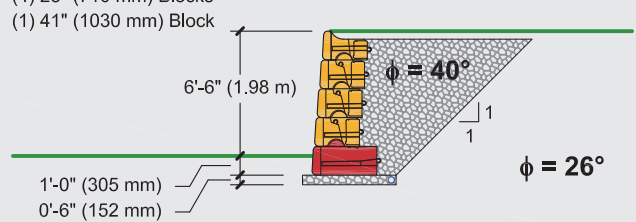

### 6 BLOCK HIGH SECTION

(4) 28" (710 mm) Blocks  
(2) 41" (1030 mm) Blocks

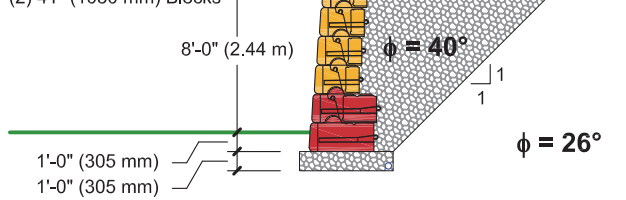

### 7 BLOCK HIGH SECTION

(4) 28" (710 mm) Blocks  
(2) 41" (1030 mm) Blocks  
(1) 60" (1520 mm) Block

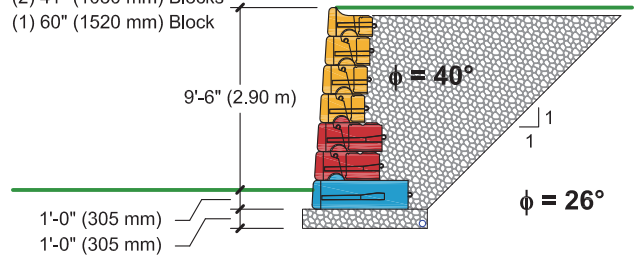

### 8 BLOCK HIGH SECTION

(4) 28" (710 mm) Blocks  
(2) 41" (1030 mm) Blocks  
(2) 60" (1520 mm) Blocks

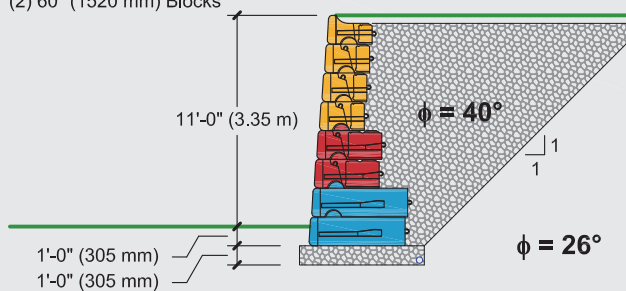

### 9 BLOCK HIGH SECTION

(3) 28" (710 mm) Blocks  
(3) 41" (1030 mm) Blocks  
(3) 60" (1520 mm) Blocks

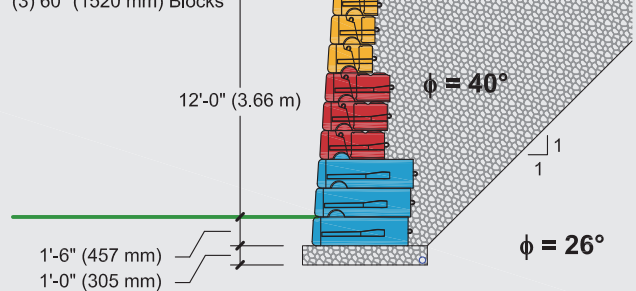

### Legend:

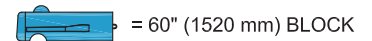
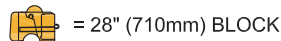

**SEE NOTES AND RECOMMENDED DETAILS AT START OF PRELIMINARY HEIGHT GUIDE.**

# Preliminary Height Guide

$\phi = 40^\circ$  over  $26^\circ$  | CRUSHED STONE BACKFILL REPLACING SILTY or CLAYEY SAND

**LOAD CONDITION A** | NO LIVE LOAD SURCHARGE, NO BACK SLOPE, NO TOE SLOPE

## 10 BLOCK HIGH SECTION

- (3) 28" (710 mm) Blocks
- (3) 41" (1030 mm) Blocks
- (4) 60" (1520 mm) Blocks

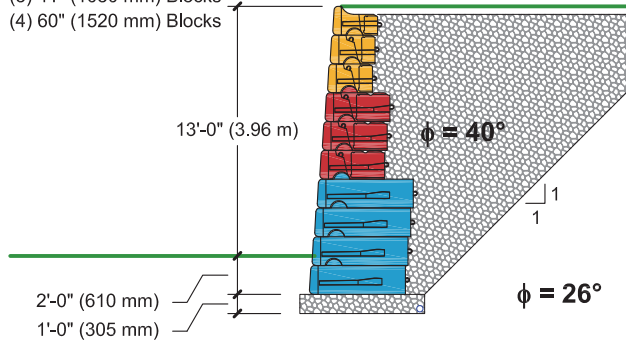

## 11 BLOCK HIGH SECTION

- (2) 28" (710 mm) Blocks
- (4) 41" (1030 mm) Blocks
- (5) 60" (1520 mm) Blocks

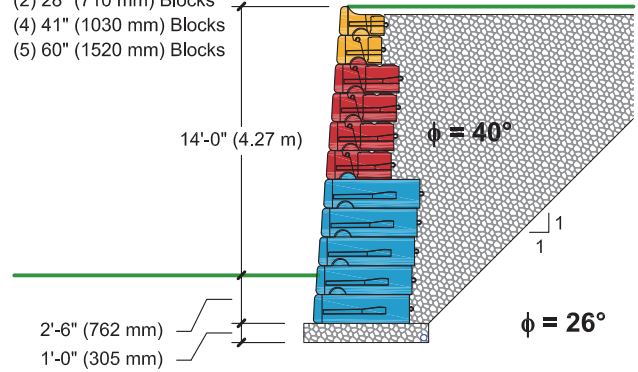

## 12 BLOCK HIGH SECTION

- (2) 28" (710 mm) Blocks
- (4) 41" (1030 mm) Blocks
- (6) 60" (1520 mm) Blocks

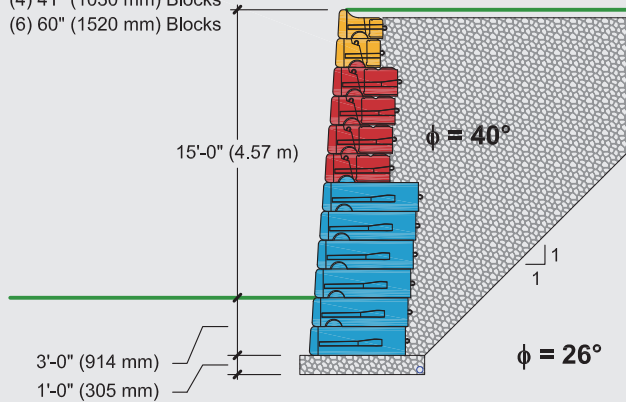



## WANT TO DO MORE? REDI-ROCK WALL ALLOWS YOU TO:

- Incorporate one or more rows of Planter blocks.
- Incorporate one or more rows of 9" (230 mm) Setback blocks.
- Use Limestone or Cobblestone face blocks.
- Use a different infill stone.
- Evaluate an expanded range of soils or loading conditions.
- Include seismic loads.
- Include water (hydrostatic loads).

[Download the software at redi-rock.com](http://redi-rock.com)

### Legend:

 = 28" (710mm) BLOCK

 = 41" (1030 mm) BLOCK

 = 60" (1520 mm) BLOCK

**SEE NOTES AND RECOMMENDED DETAILS AT START OF PRELIMINARY HEIGHT GUIDE.**

# Preliminary Height Guide

$\phi = 40^\circ$  over  $26^\circ$  | CRUSHED STONE BACKFILL REPLACING SILTY or CLAYEY SAND

**LOAD CONDITION B** | 250 lb/ft<sup>2</sup> (12 kPa) LIVE LOAD SURCHARGE, NO BACK SLOPE, NO TOE SLOPE

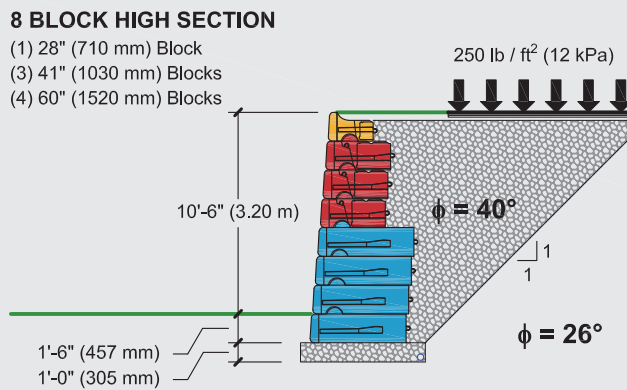
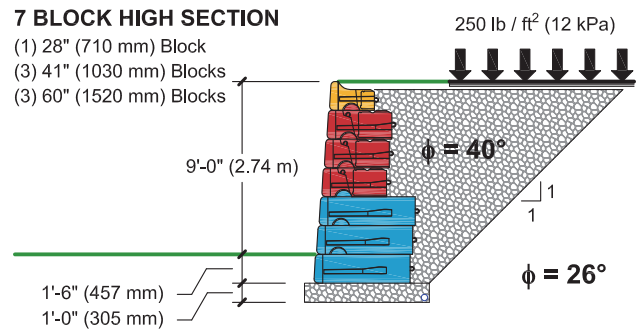
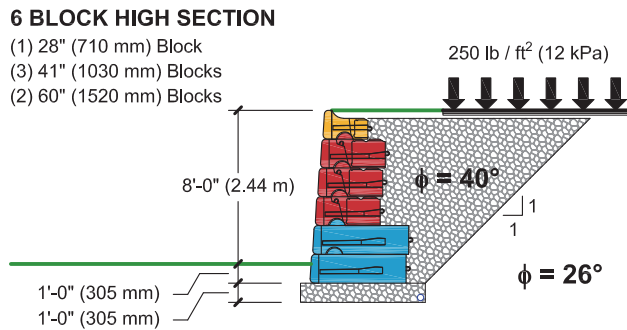
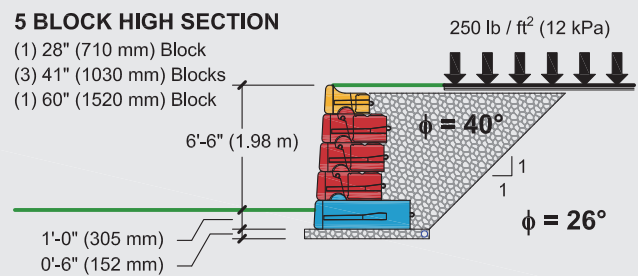
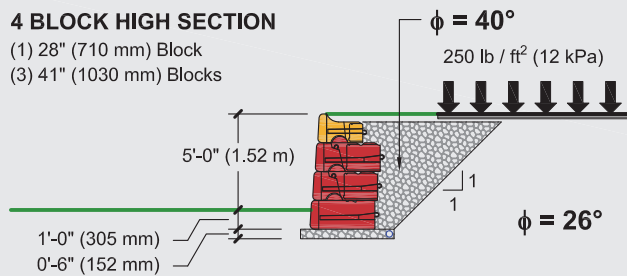
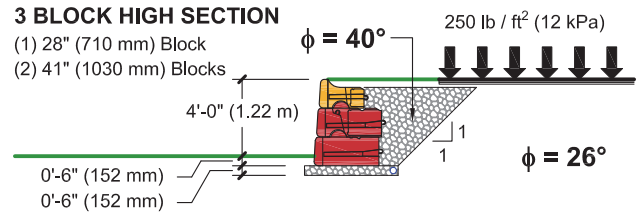
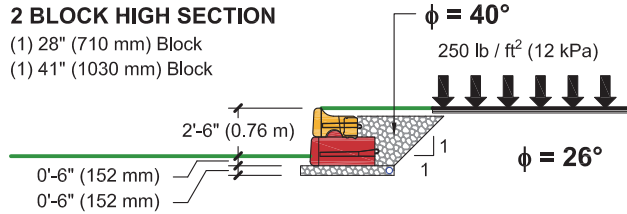

**Legend:**

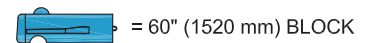
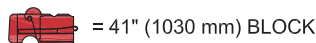
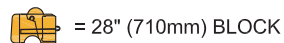

**SEE NOTES AND RECOMMENDED DETAILS AT START OF PRELIMINARY HEIGHT GUIDE.**

# Preliminary Height Guide

$\phi = 40^\circ$  over  $26^\circ$  | CRUSHED STONE BACKFILL REPLACING SILTY or CLAYEY SAND

**LOAD CONDITION C** | 1 : 2.5 BACK SLOPE, NO TOE SLOPE, NO LIVE LOAD SURCHARGE

### 2 BLOCK HIGH SECTION

- (1) 28" (710 mm) Block
- (1) 41" (1030 mm) Block

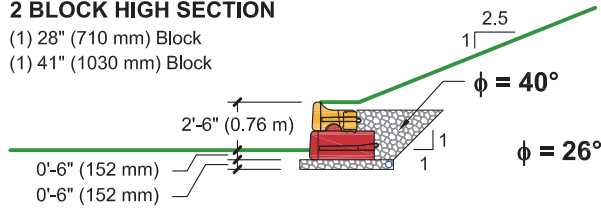

### 3 BLOCK HIGH SECTION

- (2) 28" (710 mm) Blocks
- (1) 41" (1030 mm) Block

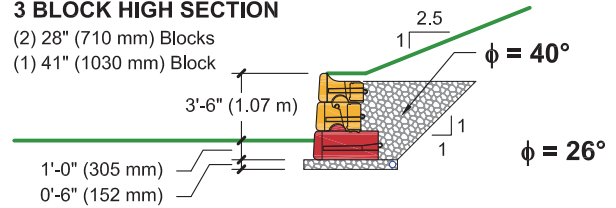

### 4 BLOCK HIGH SECTION

- (2) 28" (710 mm) Blocks
- (2) 41" (1030 mm) Blocks

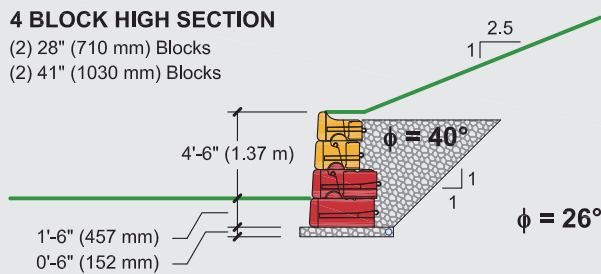

### 5 BLOCK HIGH SECTION

- (2) 28" (710 mm) Blocks
- (2) 41" (1030 mm) Blocks
- (1) 60" (1520 mm) Block

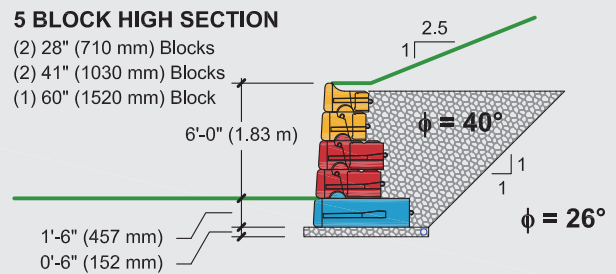

### 6 BLOCK HIGH SECTION

- (2) 28" (710 mm) Blocks
- (2) 41" (1030 mm) Blocks
- (2) 60" (1520 mm) Blocks

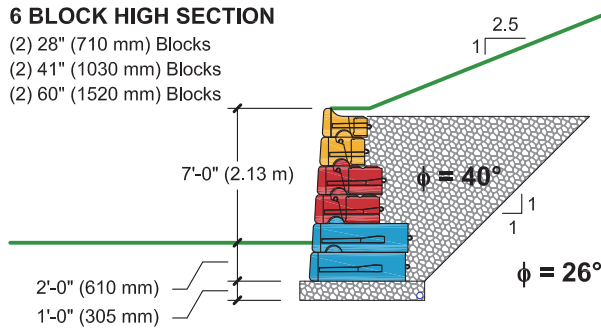

## WANT TO DO MORE? REDI-ROCK WALL ALLOWS YOU TO:

- Incorporate one or more rows of Planter blocks.
- Incorporate one or more rows of 9" (230 mm) Setback blocks.
- Use Limestone or Cobblestone face blocks.
- Use a different infill stone.
- Evaluate an expanded range of soils or loading conditions.
- Include seismic loads.
- Include water (hydrostatic loads).

[Download the software at redi-rock.com](http://redi-rock.com)

### Legend:

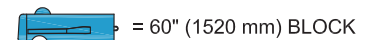
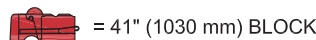
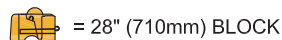

**SEE NOTES AND RECOMMENDED DETAILS AT START OF PRELIMINARY HEIGHT GUIDE.**





LARGE BATTER WALLS

**9" (230 MM) SETBACK WALLS**

34°   DENSE WELL-GRADED SAND <i>or</i> SAND AND GRAVEL.....	108
30°   FINE TO MEDIUM SAND <i>or</i> SILTY SAND .....	116
28°   SILTY SAND <i>or</i> CLAYEY SAND.....	121

## IMPORTANT NOTICE

The design specifications for Redi-Rock® blocks suggest maximum installation heights under certain assumed conditions. These wall heights were calculated using the assumed material properties and loading conditions in the *Design Resource Manual* and will vary from location to location depending on the soil properties and terrain. Since soil conditions and topography vary greatly from site to site, an engineering analysis must be performed for each wall installation.

Because Redi-Rock International does not build the blocks or install the wall system, Redi-Rock International does not assume any responsibility regarding structural stability of any particular block or particular wall system. In addition, Redi-Rock International assumes no responsibility in connection with any injury, death, or property damage claim whatsoever whether asserted against a Lessee, Leasor, Purchaser or others, arising out of or attributable to the operation of or products produced with Redi-Rock International equipment.

# Preliminary Height Guide

This preliminary height guide has been prepared showing Redi-Rock walls in a variety of assumed conditions. It is intended to give the specifier an idea of what block types are required and what heights are achievable with Redi-Rock in different applications. A combination of Redi-Rock 28" (710 mm), 41" (1030 mm), and 60" (1520 mm) wide blocks with knobs in the 9" (230 mm) setback position are used to provide the most efficient cross-section available in the different conditions.

Several assumptions have been made in preparation of the guide. They are listed in the notes below. If these assumptions do not match the wall section under consideration, block selections and achievable heights may vary from the sections shown in this guide. All wall sections for construction must be designed by a registered Professional Engineer using the actual conditions of the site.

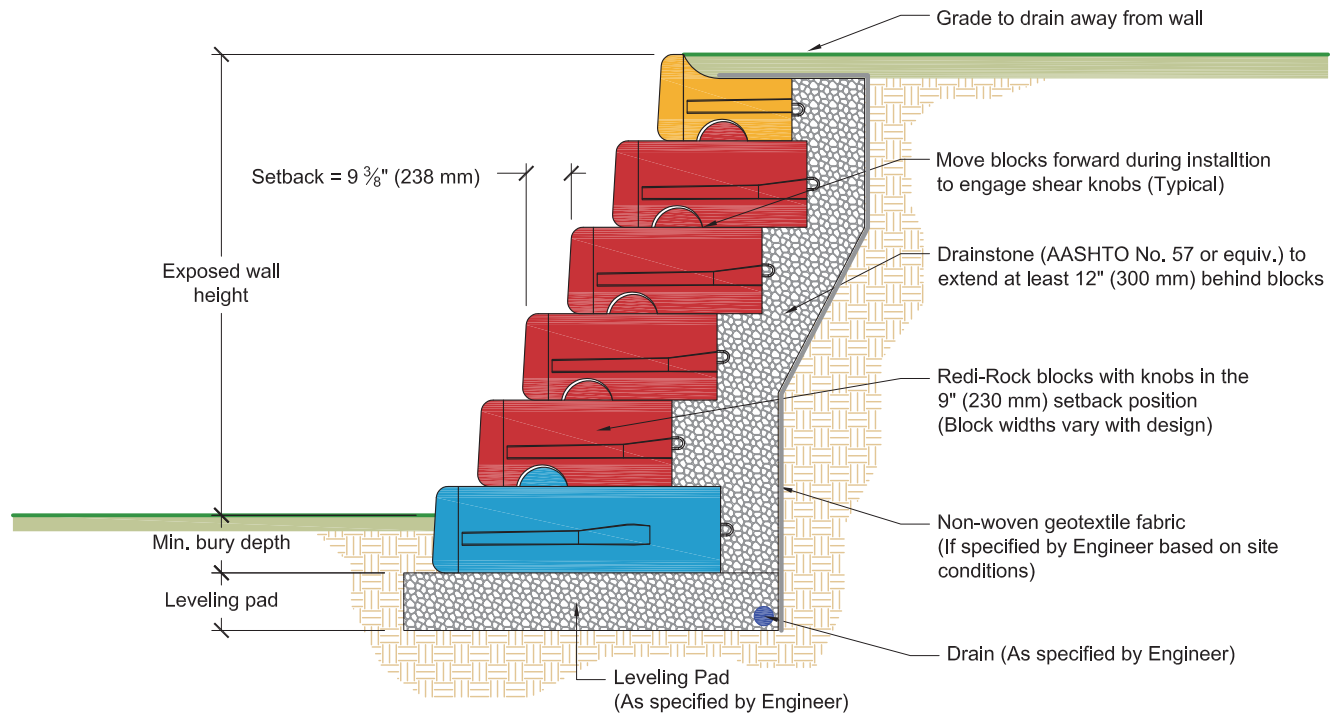

## Notes:

This preliminary guide has been prepared for three different soil types and three different load conditions to give an indication of the performance of Redi-Rock walls. **Redi-Rock walls are not limited to these conditions.** Specific wall sections can be designed for different soil and loading conditions.

Unit weight of soil is assumed to be 120 lb/ft<sup>3</sup> (18.85 kN/m<sup>3</sup>) or 130 lb/ft<sup>3</sup> (20.4 kN/m<sup>3</sup>) as noted for each section of this preliminary guide.

Minimum factors of safety are 1.5 for sliding, 1.5 for overturning, 2.0 for bearing capacity, and 1.3 for global stability. Other factors of safety will result in changes from the wall heights and block selections shown in this guide.

No seismic or hydrostatic loads were included in this preliminary guide.

Ledgestone texture blocks were used to prepare this preliminary guide. Achievable wall heights and block selections for other textures may vary.

Independent barrier design at the top of the wall must be performed for site-specific conditions. Barrier requirements may result in changes to available wall heights and block selections from those shown in this guide.

**Wall stability needs to be verified in the final design for site specific conditions.**

The wall design shall address both internal and external drainage and shall be evaluated by the Professional Engineer who is responsible for the final wall design.

Backfill material to be compacted to 90% modified proctor density (ASTM D1557).

All Redi-Rock International Wall System Specifications and installation recommendations should be followed.

Construction oversight should be provided on all walls to ensure proper construction according to your detailed design drawings.

Not tall enough? Greater wall heights are achievable with select backfill and/or mechanically stabilized earth Redi-Rock walls.

Redi-Rock products are manufactured by independently owned, licensed manufacturers. Product offerings will vary between manufacturers. Contact your local manufacturer to determine what products are available for your job.

These block selection and height guides were prepared by Redi-Rock International for estimating and conceptual design purposes only. All information is believed to be true and accurate; however, Redi-Rock International assumes no responsibility for the use of these preliminary guides for actual construction. Determination of the suitability of each preliminary guide is the sole responsibility of the user. **Final designs for construction purposes must be performed by a registered Professional Engineer, using the actual conditions of the proposed site.**

# Preliminary Height Guide

## $\phi = 34^\circ$ | DENSE WELL-GRADED SAND or SAND AND GRAVEL

Standard batter gravity walls	SECTION 1 OF 3
Assumed retained and foundation soils for this Section	SW, GW
Internal angle of friction	$\phi = 34^\circ$
Unit weight	$\gamma = 130 \text{ lb / ft}^3$ (20.4 kN / m <sup>3</sup> )
Cohesion	$c = 0 \text{ lb / ft}^2$ (0 kPa)

**LOAD CONDITION A** | NO LIVE LOAD SURFACE, NO BACK SLOPE, NO TOE SLOPE .....109

**LOAD CONDITION B** | 250 lb/ft<sup>2</sup> (12 kPa) LIVE LOAD SURCHARGE, NO BACK SLOPE, NO TOE SLOPE.....112

**LOAD CONDITION C** | 1 : 2.5 BACK SLOPE, NO TOE SLOPE, NO LIVE LOAD SURCHARGE .....114

9" (230 mm) SETBACK WALLS

ALLOWABLE STRESS DESIGN

# Preliminary Height Guide

$\phi = 34^\circ$  | DENSE WELL-GRADED SAND or SAND AND GRAVEL

**LOAD CONDITION A** | NO LIVE LOAD SURCHARGE, NO BACK SLOPE, NO TOE SLOPE

### 2 BLOCK HIGH SECTION

- (1) 28" (710 mm) Top Block
- (1) 41" (1030 mm) Block

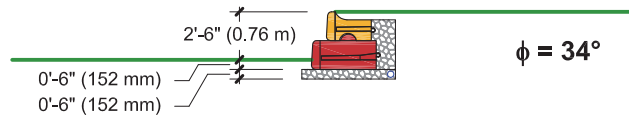

### 3 BLOCK HIGH SECTION

- (1) 28" (710 mm) Top Block
- (2) 41" (1030 mm) Blocks

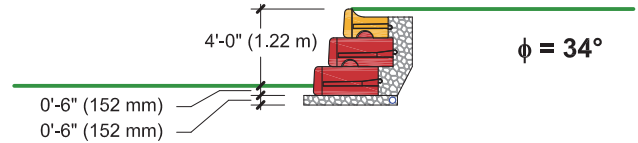

### 4 BLOCK HIGH SECTION

- (1) 28" (710 mm) Top Block
- (3) 41" (1030 mm) Blocks

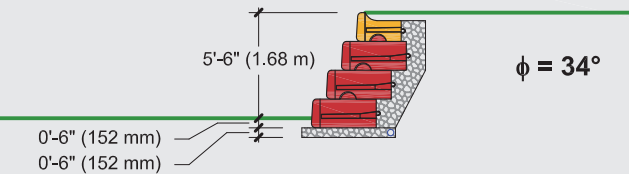

### 5 BLOCK HIGH SECTION

- (1) 28" (710 mm) Top Block
- (4) 41" (1030 mm) Blocks

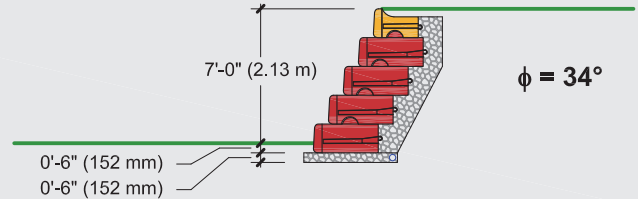

### 6 BLOCK HIGH SECTION

- (1) 28" (710 mm) Top Block
- (5) 41" (1030 mm) Blocks

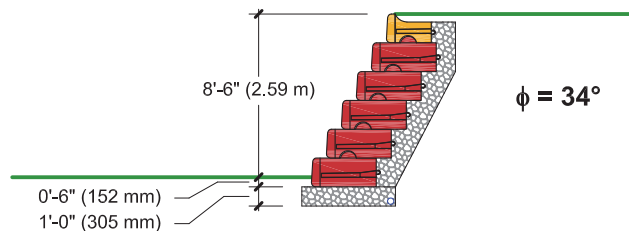

### 7 BLOCK HIGH SECTION

- (1) 28" (710 mm) Top Block
- (6) 41" (1030 mm) Blocks

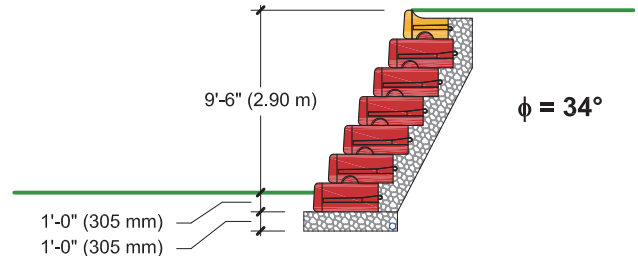

### 8 BLOCK HIGH SECTION

- (1) 28" (710 mm) Top Block
- (7) 41" (1030 mm) Blocks

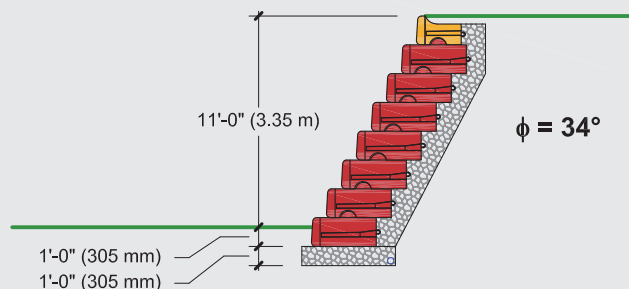

### 9 BLOCK HIGH SECTION

- (1) 28" (710 mm) Top Block
- (8) 41" (1030 mm) Blocks

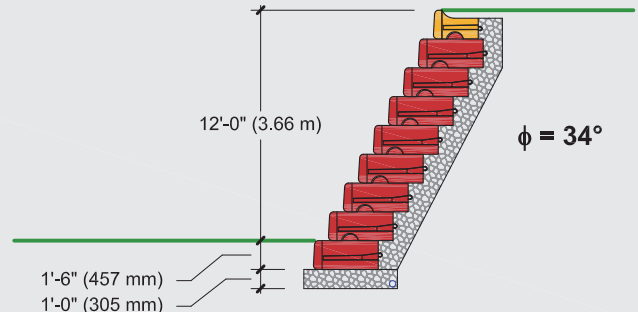

### Legend:

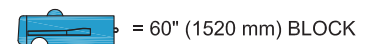
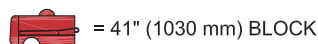
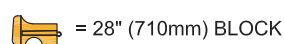

**SEE NOTES AND RECOMMENDED DETAILS AT START OF PRELIMINARY HEIGHT GUIDE.**

9" (230 mm) SETBACK WALLS

ALLOWABLE STRESS DESIGN

# Preliminary Height Guide

$\phi = 34^\circ$  | DENSE WELL-GRADED SAND or SAND AND GRAVEL

**LOAD CONDITION A** | NO LIVE LOAD SURCHARGE, NO BACK SLOPE, NO TOE SLOPE

## 10 BLOCK HIGH SECTION

(1) 28" (710 mm) Top Block  
(9) 41" (1030 mm) Blocks

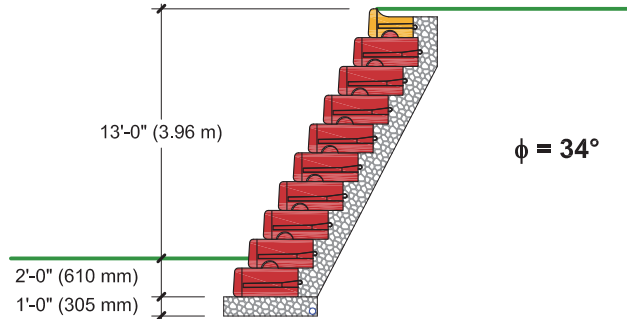

## 11 BLOCK HIGH SECTION

(1) 28" (710 mm) Top Block  
(10) 41" (1030 mm) Blocks

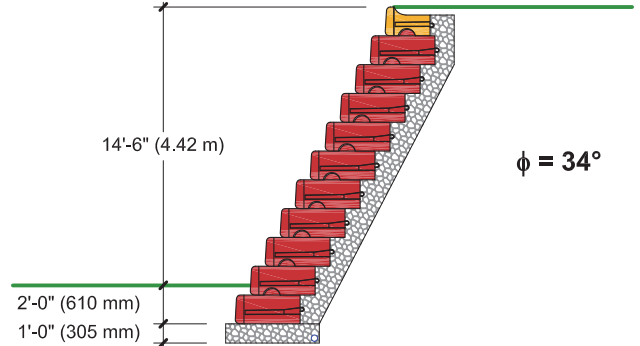

## 12 BLOCK HIGH SECTION

(1) 28" (710 mm) Top Block  
(11) 41" (1030 mm) Blocks

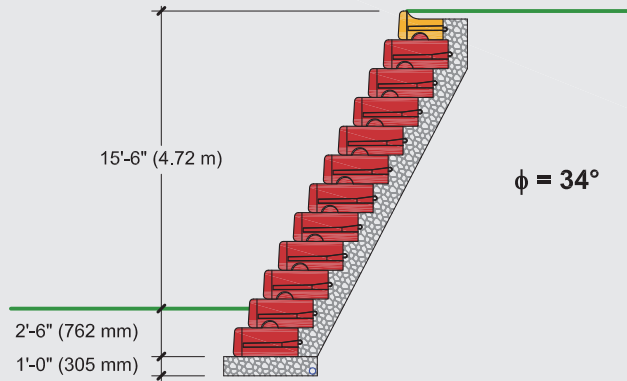

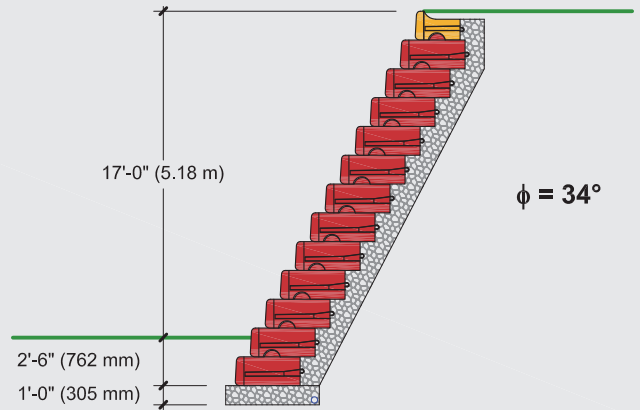

## 13 BLOCK HIGH SECTION

(1) 28" (710 mm) Top Block  
(12) 41" (1030 mm) Blocks



### Legend:

 = 28" (710mm) BLOCK

 = 41" (1030 mm) BLOCK

 = 60" (1520 mm) BLOCK

**SEE NOTES AND RECOMMENDED DETAILS AT START OF PRELIMINARY HEIGHT GUIDE.**

9" (230 mm) SETBACK WALLS

ALLOWABLE STRESS DESIGN

# Preliminary Height Guide

$\phi = 34^\circ$  | DENSE WELL-GRADED SAND or SAND AND GRAVEL

**LOAD CONDITION A** | NO LIVE LOAD SURCHARGE, NO BACK SLOPE, NO TOE SLOPE

### 14 BLOCK HIGH SECTION

- (1) 28" (710 mm) Top Block
- (13) 41" (1030 mm) Blocks

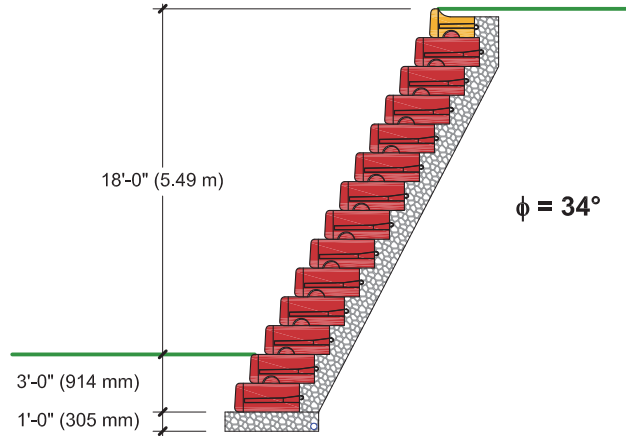

### 15 BLOCK HIGH SECTION

- (1) 28" (710 mm) Top Block
- (9) 41" (1030 mm) Blocks
- (5) 60" (1520 mm) Blocks

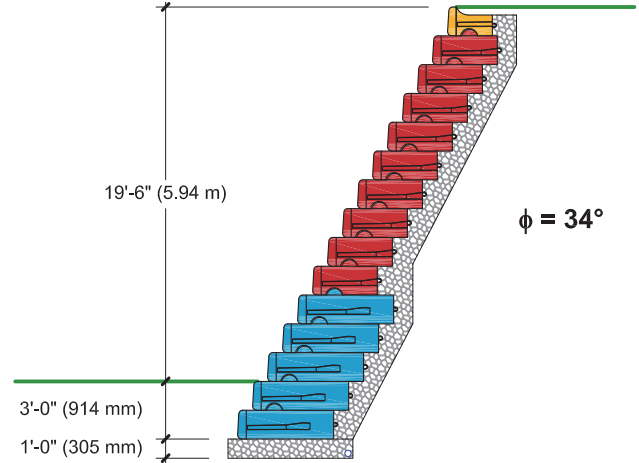

### 16 BLOCK HIGH SECTION

- (1) 28" (710 mm) Top Block
- (8) 41" (1030 mm) Blocks
- (7) 60" (1520 mm) Blocks

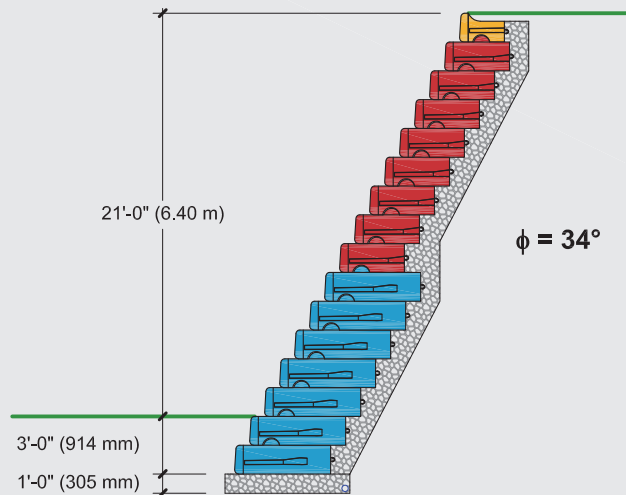

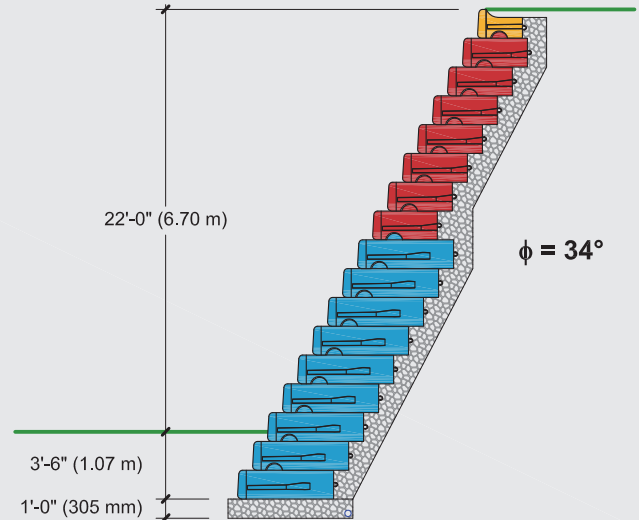

### 17 BLOCK HIGH SECTION

- (1) 28" (710 mm) Top Block
- (7) 41" (1030 mm) Blocks
- (9) 60" (1520 mm) Blocks



### Legend:

 = 28" (710mm) BLOCK

 = 41" (1030 mm) BLOCK

 = 60" (1520 mm) BLOCK

**SEE NOTES AND RECOMMENDED DETAILS AT START OF PRELIMINARY HEIGHT GUIDE.**

9" (230 mm) SETBACK WALLS

ALLOWABLE STRESS DESIGN

# Preliminary Height Guide

$\phi = 34^\circ$  | DENSE WELL-GRADED SAND or SAND AND GRAVEL

**LOAD CONDITION B** | 250 lb/ft<sup>2</sup> (12 kPa) LIVE LOAD SURCHARGE, NO BACK SLOPE, NO TOE SLOPE

### 2 BLOCK HIGH SECTION

- (1) 28" (710 mm) Top Block
- (1) 41" (1030 mm) Block

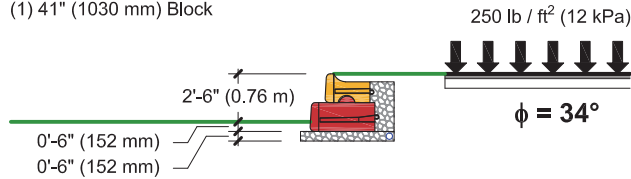

### 3 BLOCK HIGH SECTION

- (1) 28" (710 mm) Top Block
- (2) 41" (1030 mm) Blocks

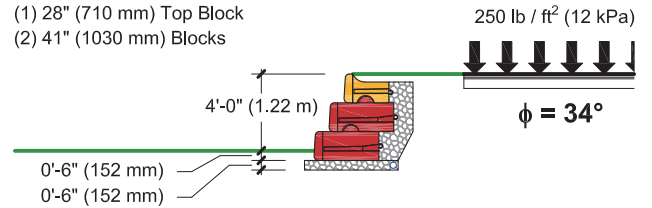

### 4 BLOCK HIGH SECTION

- (1) 28" (710 mm) Top Block
- (3) 41" (1030 mm) Blocks

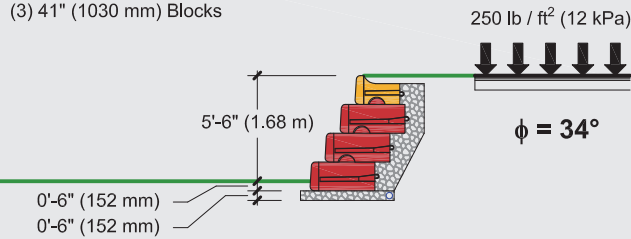

### 5 BLOCK HIGH SECTION

- (1) 28" (710 mm) Top Block
- (4) 41" (1030 mm) Blocks

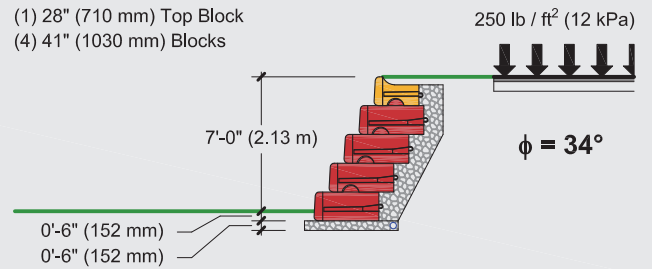

### 6 BLOCK HIGH SECTION

- (1) 28" (710 mm) Top Block
- (5) 41" (1030 mm) Blocks

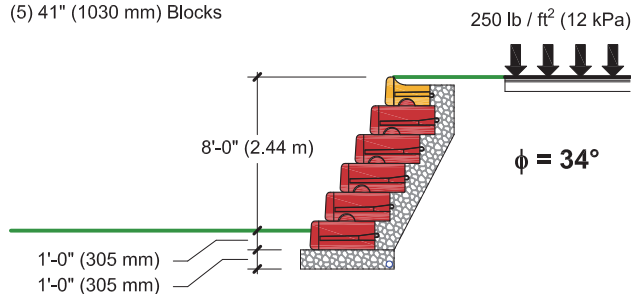

### 7 BLOCK HIGH SECTION

- (1) 28" (710 mm) Top Block
- (6) 41" (1030 mm) Blocks

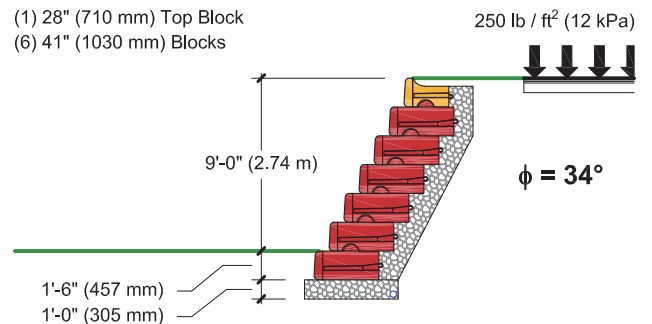

### 8 BLOCK HIGH SECTION

- (1) 28" (710 mm) Top Block
- (7) 41" (1030 mm) Blocks

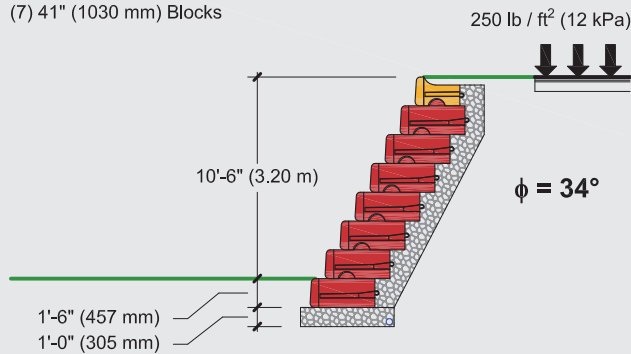

### 9 BLOCK HIGH SECTION

- (1) 28" (710 mm) Top Block
- (5) 41" (1030 mm) Blocks
- (3) 60" (1520 mm) Blocks

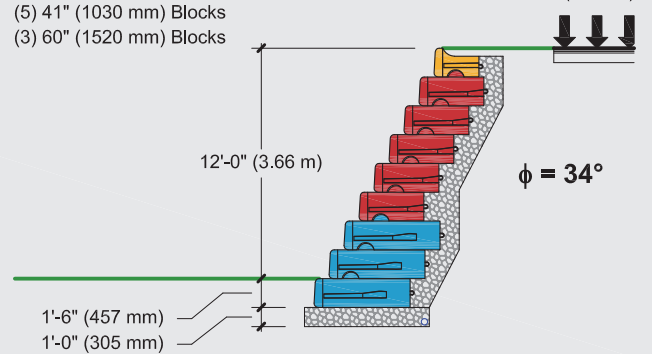

### Legend:

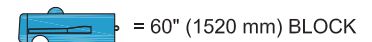
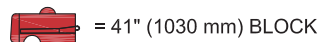
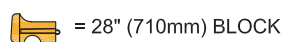

**SEE NOTES AND RECOMMENDED DETAILS AT START OF PRELIMINARY HEIGHT GUIDE.**

9" (230 mm) SETBACK WALLS

ALLOWABLE STRESS DESIGN

# Preliminary Height Guide

$\phi = 34^\circ$  | DENSE WELL-GRADED SAND or SAND AND GRAVEL

**LOAD CONDITION B** | 250 lb/ft<sup>2</sup> (12 kPa) LIVE LOAD SURCHARGE, NO BACK SLOPE, NO TOE SLOPE

## 10 BLOCK HIGH SECTION

- (1) 28" (710 mm) Top Block
- (5) 41" (1030 mm) Blocks
- (4) 60" (1520 mm) Blocks

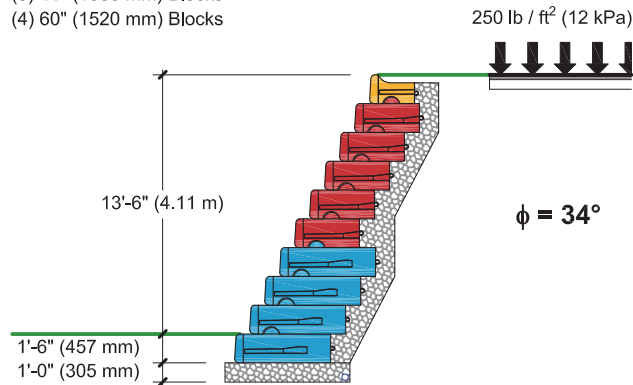

## 11 BLOCK HIGH SECTION

- (1) 28" (710 mm) Top Block
- (5) 41" (1030 mm) Blocks
- (5) 60" (1520 mm) Blocks

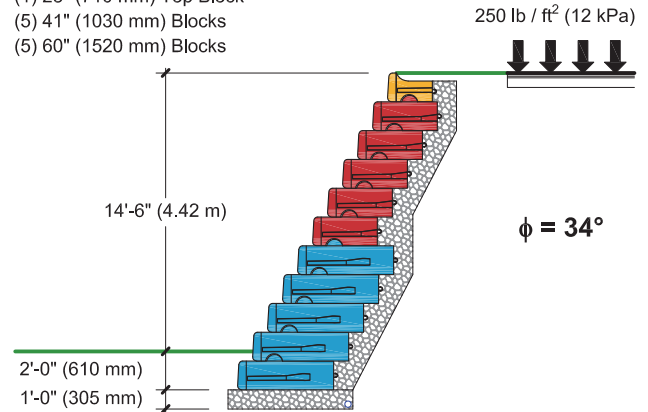

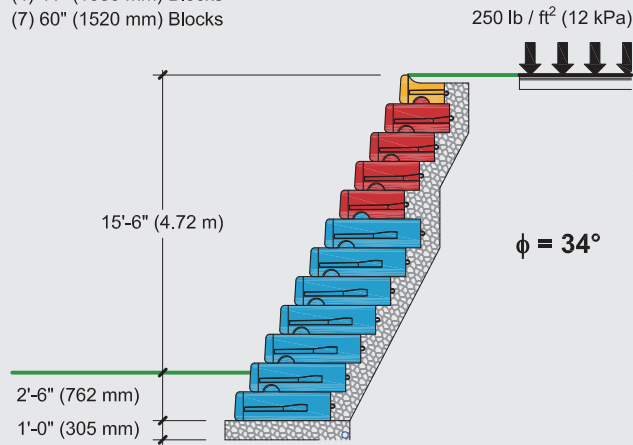

## 12 BLOCK HIGH SECTION

- (1) 28" (710 mm) Top Block
- (4) 41" (1030 mm) Blocks
- (7) 60" (1520 mm) Blocks



### Legend:

 = 28" (710mm) BLOCK

 = 41" (1030 mm) BLOCK

 = 60" (1520 mm) BLOCK

**SEE NOTES AND RECOMMENDED DETAILS AT START OF PRELIMINARY HEIGHT GUIDE.**

# Preliminary Height Guide

$\phi = 34^\circ$  | DENSE WELL-GRADED SAND or SAND AND GRAVEL

**LOAD CONDITION C** | 1 : 2.5 BACK SLOPE, NO TOE SLOPE, NO LIVE LOAD SURCHARGE

### 2 BLOCK HIGH SECTION

- (1) 28" (710 mm) Top Block
- (1) 41" (1030 mm) Block

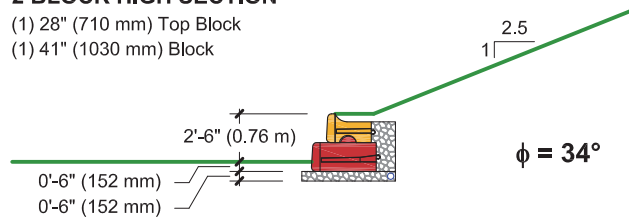

### 3 BLOCK HIGH SECTION

- (1) 28" (710 mm) Top Block
- (2) 41" (1030 mm) Blocks

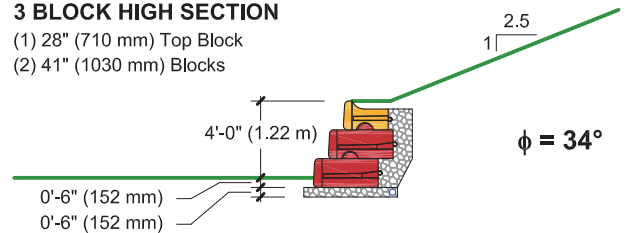

### 4 BLOCK HIGH SECTION

- (1) 28" (710 mm) Top Block
- (3) 41" (1030 mm) Blocks

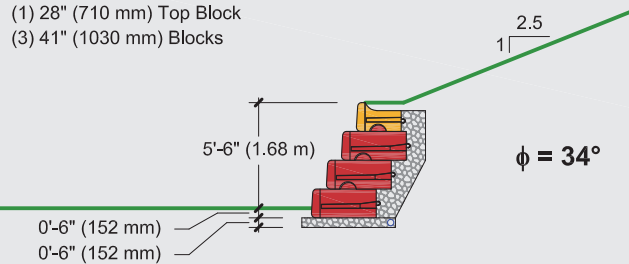

### 5 BLOCK HIGH SECTION

- (1) 28" (710 mm) Top Block
- (4) 41" (1030 mm) Blocks

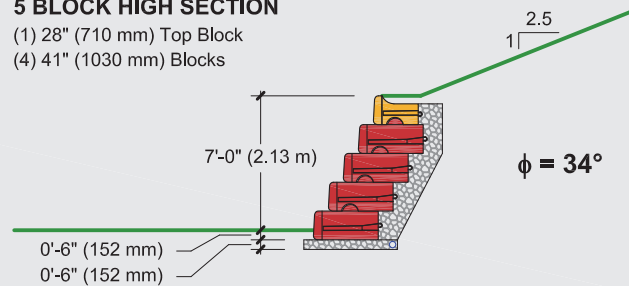

### 6 BLOCK HIGH SECTION

- (1) 28" (710 mm) Top Block
- (5) 41" (1030 mm) Blocks

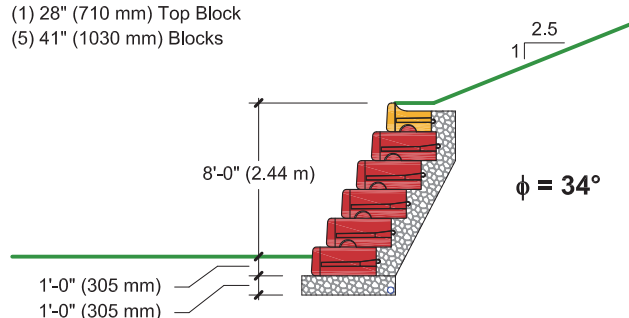

### 7 BLOCK HIGH SECTION

- (1) 28" (710 mm) Top Block
- (6) 41" (1030 mm) Blocks

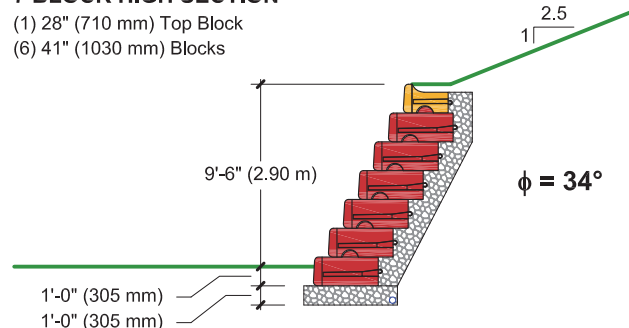

### 8 BLOCK HIGH SECTION

- (1) 28" (710 mm) Top Block
- (7) 41" (1030 mm) Blocks

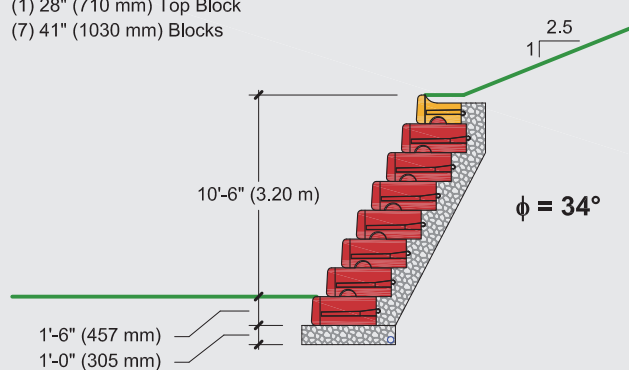

### 9 BLOCK HIGH SECTION

- (1) 28" (710 mm) Top Block
- (4) 41" (1030 mm) Blocks
- (4) 60" (1520 mm) Blocks

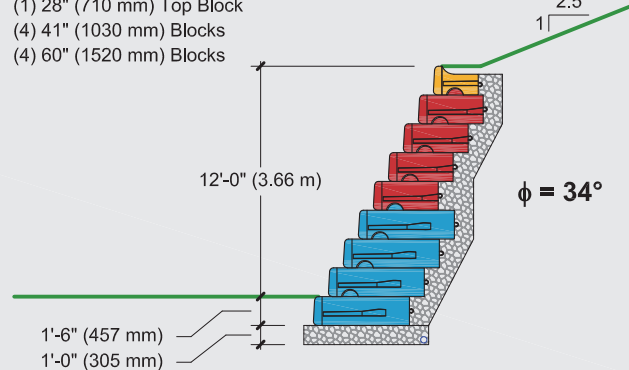

### Legend:

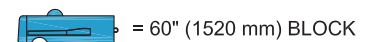
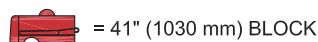
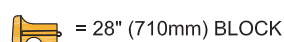

**SEE NOTES AND RECOMMENDED DETAILS AT START OF PRELIMINARY HEIGHT GUIDE.**

9" (230 mm) SETBACK WALLS

ALLOWABLE STRESS DESIGN

# Preliminary Height Guide

$\phi = 34^\circ$  | DENSE WELL-GRADED SAND or SAND AND GRAVEL

**LOAD CONDITION C** | 1 : 2.5 BACK SLOPE, NO TOE SLOPE, NO LIVE LOAD SURCHARGE

**10 BLOCK HIGH SECTION**

- (1) 28" (710 mm) Top Block
- (4) 41" (1030 mm) Blocks
- (5) 60" (1520 mm) Blocks

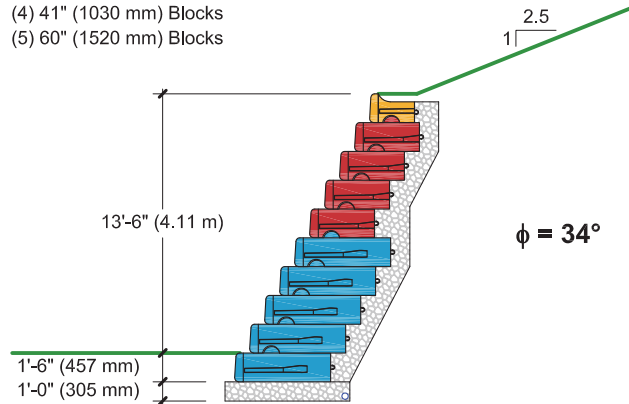

**Legend:**

 = 28" (710mm) BLOCK

 = 41" (1030 mm) BLOCK

 = 60" (1520 mm) BLOCK

**SEE NOTES AND RECOMMENDED DETAILS AT START OF PRELIMINARY HEIGHT GUIDE.**

# Preliminary Height Guide

## $\phi = 30^\circ$ | FINE TO MEDIUM SAND or SILTY SAND

Standard batter gravity walls	SECTION 2 OF 3
Assumed retained and foundation soils for this Section	SW, SP, SM
Internal angle of friction	$\phi = 30^\circ$
Unit weight	$\gamma = 120 \text{ lb / ft}^3$ (18.8 kN / m <sup>3</sup> )
Cohesion	$c = 0 \text{ lb / ft}^2$ (0 kPa)

<b>LOAD CONDITION A</b>   NO LIVE LOAD SURFACE, NO BACK SLOPE, NO TOE SLOPE.....	117
<b>LOAD CONDITION B</b>   250 lb/ft <sup>2</sup> (12 kPa) LIVE LOAD SURCHARGE, NO BACK SLOPE, NO TOE SLOPE.....	119
<b>LOAD CONDITION C</b>   1 : 2.5 BACK SLOPE, NO TOE SLOPE, NO LIVE LOAD SURCHARGE.....	120

9" (230 mm) SETBACK WALLS

ALLOWABLE STRESS DESIGN

# Preliminary Height Guide

$\phi = 30^\circ$  | FINE TO MEDIUM SAND or SILTY SAND

**LOAD CONDITION A** | NO LIVE LOAD SURCHARGE, NO BACK SLOPE, NO TOE SLOPE

### 2 BLOCK HIGH SECTION

- (1) 28" (710 mm) Top Block
- (1) 41" (1030 mm) Block

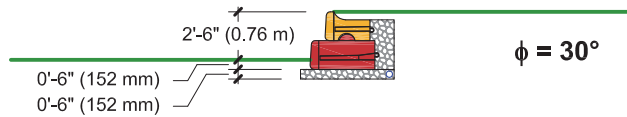

### 3 BLOCK HIGH SECTION

- (1) 28" (710 mm) Top Block
- (2) 41" (1030 mm) Blocks

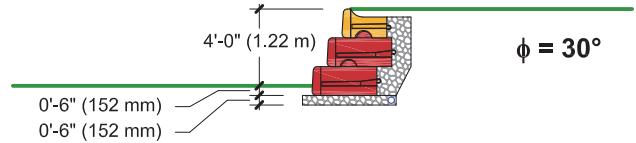

### 4 BLOCK HIGH SECTION

- (1) 28" (710 mm) Top Block
- (3) 41" (1030 mm) Blocks

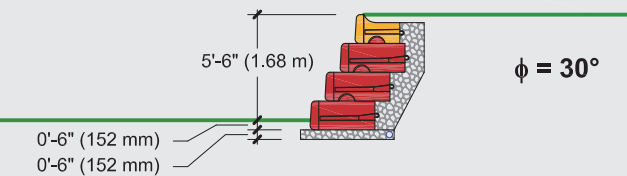

### 5 BLOCK HIGH SECTION

- (1) 28" (710 mm) Top Block
- (4) 41" (1030 mm) Blocks

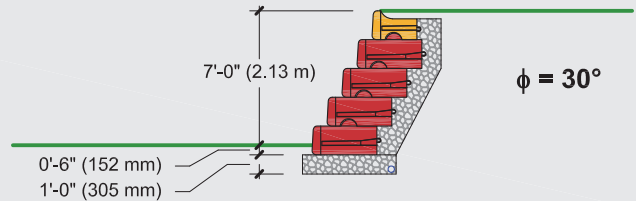

### 6 BLOCK HIGH SECTION

- (1) 28" (710 mm) Top Block
- (5) 41" (1030 mm) Blocks

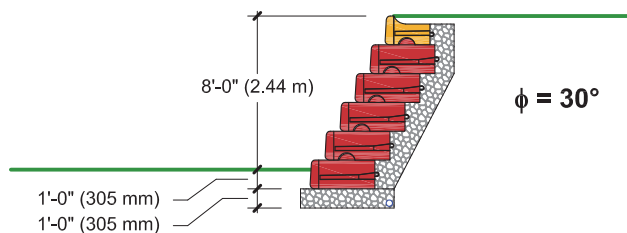

### 7 BLOCK HIGH SECTION

- (1) 28" (710 mm) Top Block
- (6) 41" (1030 mm) Blocks

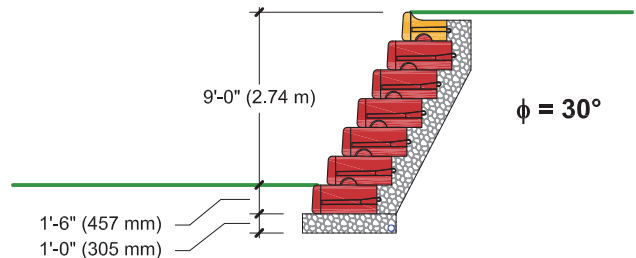

### 8 BLOCK HIGH SECTION

- (1) 28" (710 mm) Top Block
- (7) 41" (1030 mm) Blocks

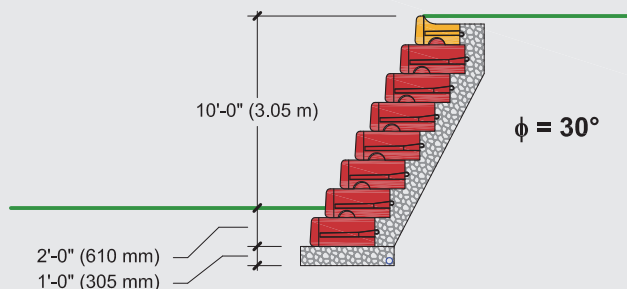

### 9 BLOCK HIGH SECTION

- (1) 28" (710 mm) Top Block
- (8) 41" (1030 mm) Blocks

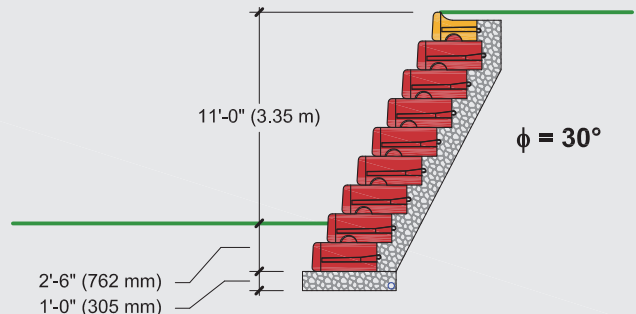

### Legend:

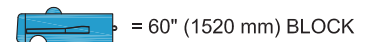
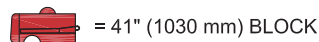
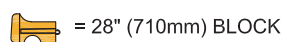

**SEE NOTES AND RECOMMENDED DETAILS AT START OF PRELIMINARY HEIGHT GUIDE.**

9" (230 mm) SETBACK WALLS

ALLOWABLE STRESS DESIGN

# Preliminary Height Guide

$\phi = 30^\circ$  | FINE TO MEDIUM SAND or SILTY SAND

**LOAD CONDITION A** | NO LIVE LOAD SURCHARGE, NO BACK SLOPE, NO TOE SLOPE

### 10 BLOCK HIGH SECTION

- (1) 28" (710 mm) Top Block
- (8) 41" (1030 mm) Blocks
- (1) 60" (1520 mm) Block

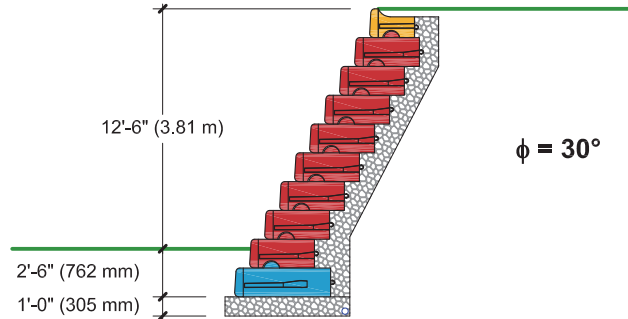

### 11 BLOCK HIGH SECTION

- (1) 28" (710 mm) Top Block
- (5) 41" (1030 mm) Blocks
- (5) 60" (1520 mm) Block

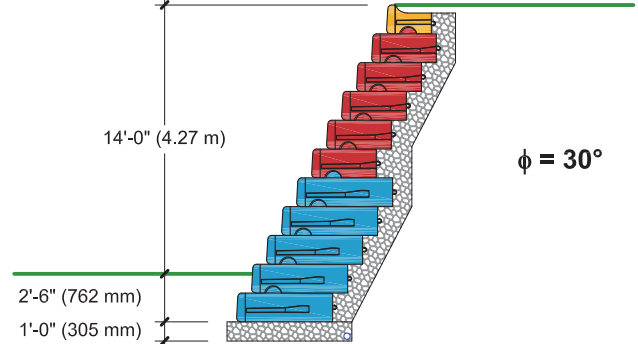

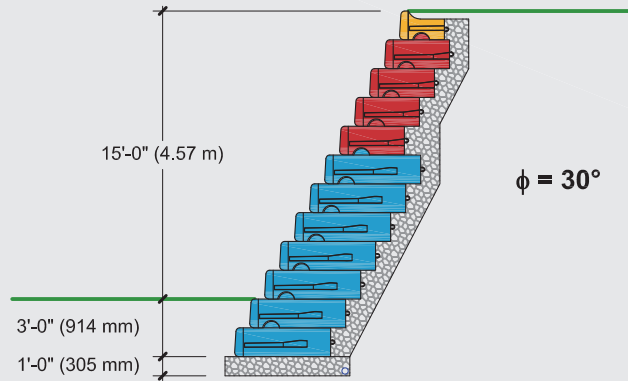

### 12 BLOCK HIGH SECTION

- (1) 28" (710 mm) Top Block
- (4) 41" (1030 mm) Blocks
- (7) 60" (1520 mm) Block



### Legend:

 = 28" (710mm) BLOCK

 = 41" (1030 mm) BLOCK

 = 60" (1520 mm) BLOCK

**SEE NOTES AND RECOMMENDED DETAILS AT START OF PRELIMINARY HEIGHT GUIDE.**

9" (230 mm) SETBACK WALLS

ALLOWABLE STRESS DESIGN

# Preliminary Height Guide

$\phi = 30^\circ$  | FINE TO MEDIUM SAND or SILTY SAND

**LOAD CONDITION B** | 250 lb/ft<sup>2</sup> (12 kPa) LIVE LOAD SURCHARGE, NO BACK SLOPE, NO TOE SLOPE

### 2 BLOCK HIGH SECTION

- (1) 28" (710 mm) Top Block
- (1) 41" (1030 mm) Block

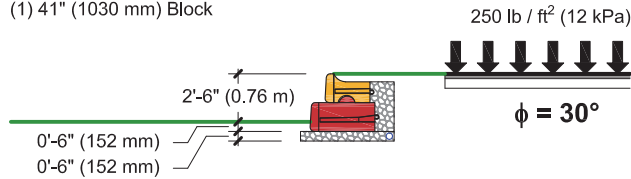

### 3 BLOCK HIGH SECTION

- (1) 28" (710 mm) Top Block
- (2) 41" (1030 mm) Blocks

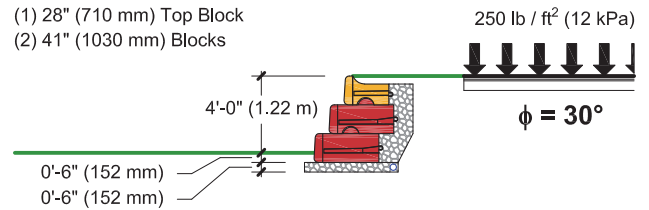

### 4 BLOCK HIGH SECTION

- (1) 28" (710 mm) Top Block
- (3) 41" (1030 mm) Blocks

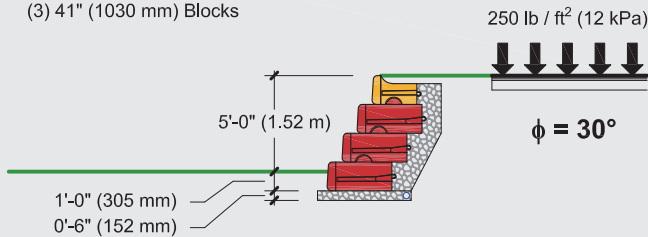

### 5 BLOCK HIGH SECTION

- (1) 28" (710 mm) Top Block
- (3) 41" (1030 mm) Blocks
- (1) 60" (1520 mm) Block

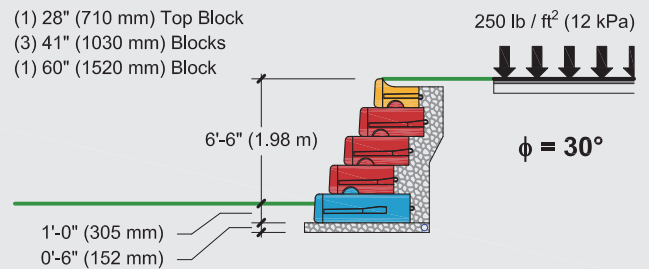

### 6 BLOCK HIGH SECTION

- (1) 28" (710 mm) Top Block
- (3) 41" (1030 mm) Blocks
- (2) 60" (1520 mm) Blocks

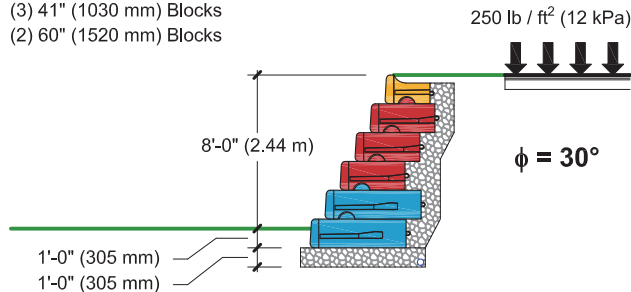

### 7 BLOCK HIGH SECTION

- (1) 28" (710 mm) Top Block
- (3) 41" (1030 mm) Blocks
- (3) 60" (1520 mm) Blocks

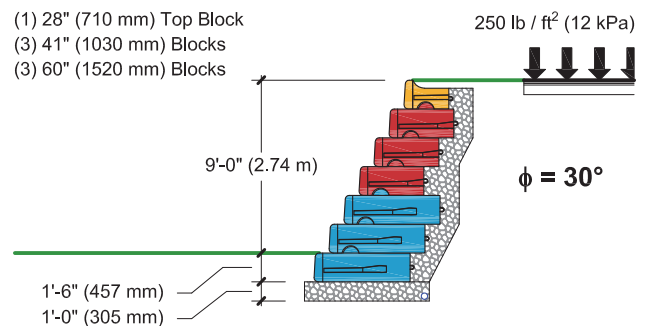

### 8 BLOCK HIGH SECTION

- (1) 28" (710 mm) Top Block
- (2) 41" (1030 mm) Blocks
- (5) 60" (1520 mm) Blocks

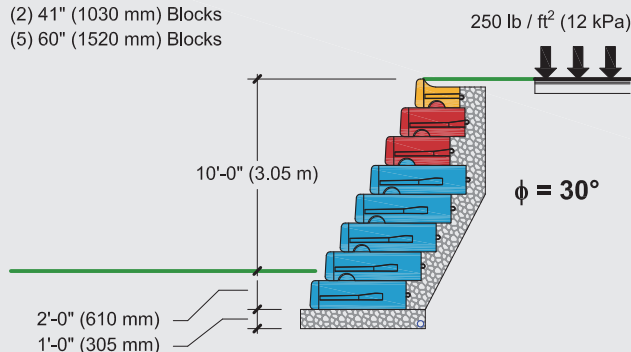

### Legend:

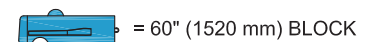
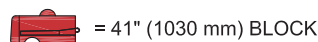
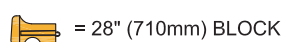

**SEE NOTES AND RECOMMENDED DETAILS AT START OF PRELIMINARY HEIGHT GUIDE.**

9" (230 mm) SETBACK WALLS

ALLOWABLE STRESS DESIGN

# Preliminary Height Guide

$\phi = 30^\circ$  | FINE TO MEDIUM SAND or SILTY SAND

**LOAD CONDITION C** | 1 : 2.5 BACK SLOPE, NO TOE SLOPE, NO LIVE LOAD SURCHARGE

### 2 BLOCK HIGH SECTION

- (1) 28" (710 mm) Top Block
- (1) 41" (1030 mm) Block

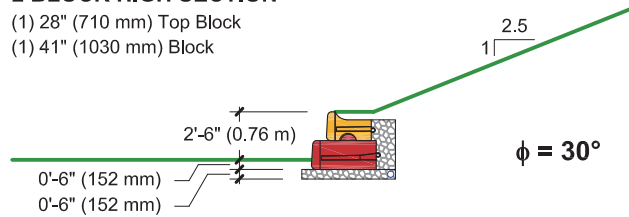

### 3 BLOCK HIGH SECTION

- (1) 28" (710 mm) Top Block
- (2) 41" (1030 mm) Blocks

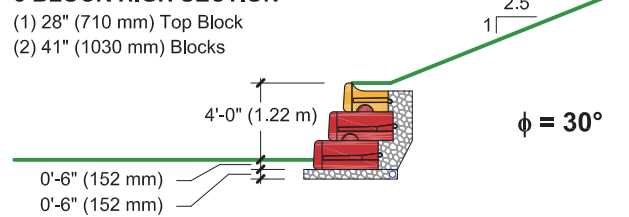

### 4 BLOCK HIGH SECTION

- (1) 28" (710 mm) Top Block
- (3) 41" (1030 mm) Blocks

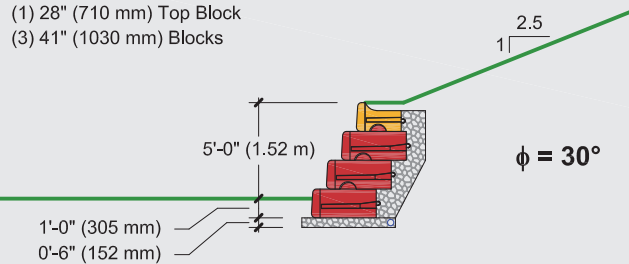

### 5 BLOCK HIGH SECTION

- (1) 28" (710 mm) Top Block
- (2) 41" (1030 mm) Blocks
- (2) 60" (1520 mm) Blocks

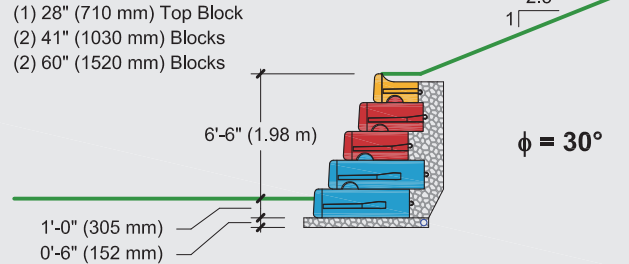

### 6 BLOCK HIGH SECTION

- (1) 28" (710 mm) Top Block
- (1) 41" (1030 mm) Blocks
- (4) 60" (1520 mm) Blocks

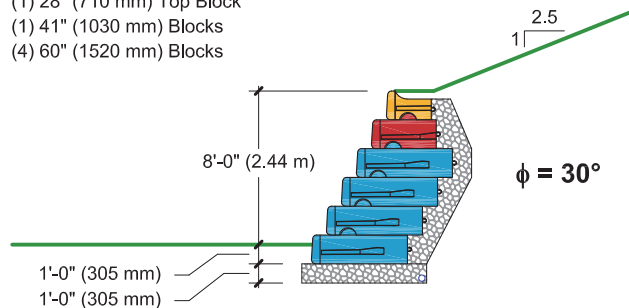

### Legend:

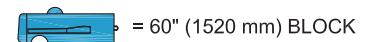
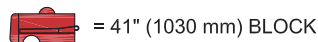
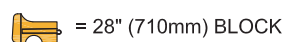

**SEE NOTES AND RECOMMENDED DETAILS AT START OF PRELIMINARY HEIGHT GUIDE.**

9" (230 mm) SETBACK WALLS

ALLOWABLE STRESS DESIGN

# Preliminary Height Guide

$\phi = 28^\circ$  | SILTY SAND or CLAYEY SAND

Standard batter gravity walls	SECTION 3 OF 3
Assumed retained and foundation soils for this Section	SM, SC
Internal angle of friction	$\phi = 28^\circ$
Unit weight	$\gamma = 120 \text{ lb / ft}^3$ (18.8 kN / m <sup>3</sup> )
Cohesion	$c = 0 \text{ lb / ft}^2$ (0 kPa)

<b>LOAD CONDITION A</b>   NO LIVE LOAD SURFACE, NO BACK SLOPE, NO TOE SLOPE .....	122
<b>LOAD CONDITION B</b>   250 lb/ft <sup>2</sup> (12 kPa) LIVE LOAD SURCHARGE, NO BACK SLOPE, NO TOE SLOPE .....	123
<b>LOAD CONDITION C</b>   1 : 2.5 BACK SLOPE, NO TOE SLOPE, NO LIVE LOAD SURCHARGE.....	124

9" (230 mm) SETBACK WALLS

ALLOWABLE STRESS DESIGN

# Preliminary Height Guide

$\phi = 28^\circ$  | SILTY SAND or CLAYEY SAND

**LOAD CONDITION A** | NO LIVE LOAD SURCHARGE, NO BACK SLOPE, NO TOE SLOPE

### 2 BLOCK HIGH SECTION

- (1) 28" (710 mm) Top Block
- (1) 41" (1030 mm) Block

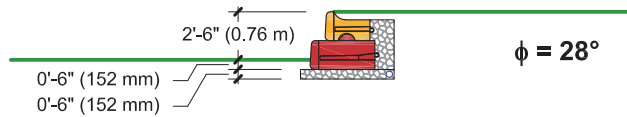

### 3 BLOCK HIGH SECTION

- (1) 28" (710 mm) Top Block
- (2) 41" (1030 mm) Blocks

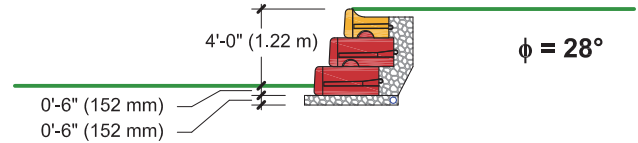

### 4 BLOCK HIGH SECTION

- (1) 28" (710 mm) Top Block
- (3) 41" (1030 mm) Blocks

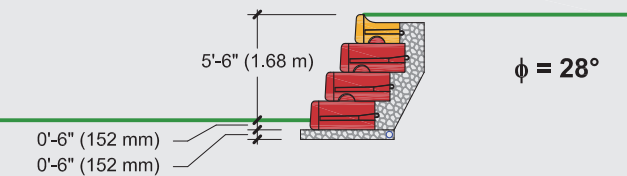

### 5 BLOCK HIGH SECTION

- (1) 28" (710 mm) Top Block
- (4) 41" (1030 mm) Blocks

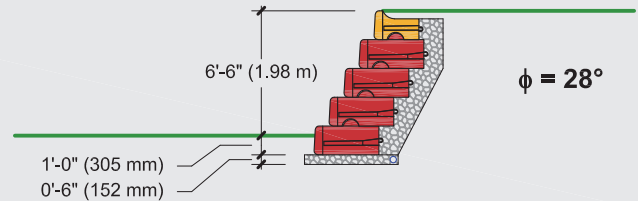

### 6 BLOCK HIGH SECTION

- (1) 28" (710 mm) Top Block
- (5) 41" (1030 mm) Blocks

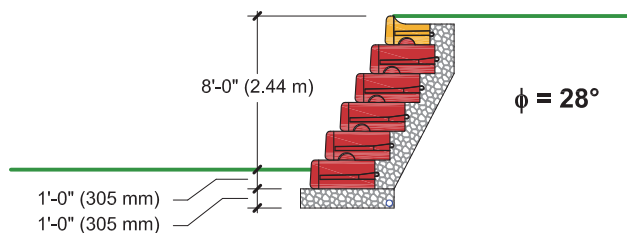

### 7 BLOCK HIGH SECTION

- (1) 28" (710 mm) Top Block
- (5) 41" (1030 mm) Blocks
- (1) 60" (1520 mm) Block

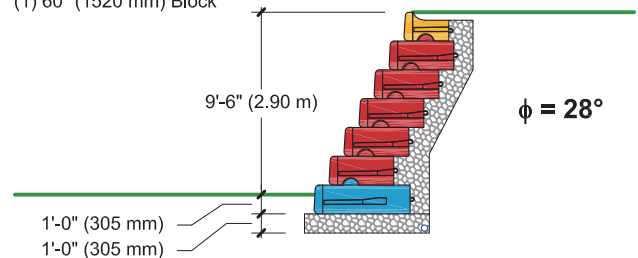

### 8 BLOCK HIGH SECTION

- (1) 28" (710 mm) Top Block
- (4) 41" (1030 mm) Blocks
- (3) 60" (1520 mm) Blocks

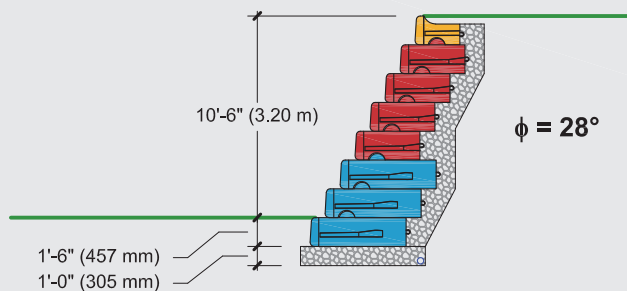

### 9 BLOCK HIGH SECTION

- (1) 28" (710 mm) Top Block
- (3) 41" (1030 mm) Blocks
- (5) 60" (1520 mm) Blocks

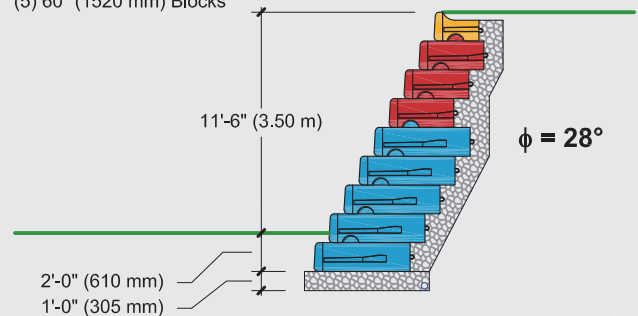

### Legend:

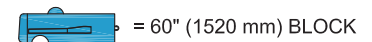
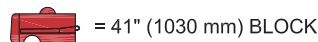
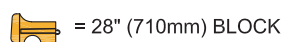

**SEE NOTES AND RECOMMENDED DETAILS AT START OF PRELIMINARY HEIGHT GUIDE.**

9" (230 mm) SETBACK WALLS

ALLOWABLE STRESS DESIGN

# Preliminary Height Guide

$\phi = 28^\circ$  | SILTY SAND or CLAYEY SAND

**LOAD CONDITION B** | 250 lb/ft<sup>2</sup> (12 kPa) LIVE LOAD SURCHARGE, NO BACK SLOPE, NO TOE SLOPE

## 2 BLOCK HIGH SECTION

- (1) 28" (710 mm) Top Block
- (1) 41" (1030 mm) Block

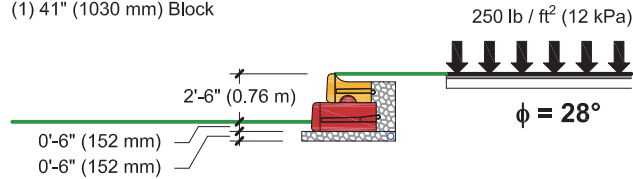

## 3 BLOCK HIGH SECTION

- (1) 28" (710 mm) Top Block
- (2) 41" (1030 mm) Blocks

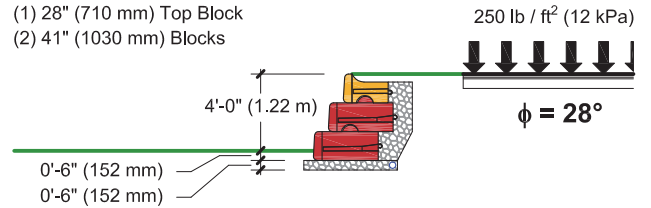

## 4 BLOCK HIGH SECTION

- (1) 28" (710 mm) Top Block
- (2) 41" (1030 mm) Blocks
- (1) 60" (1520 mm) Block

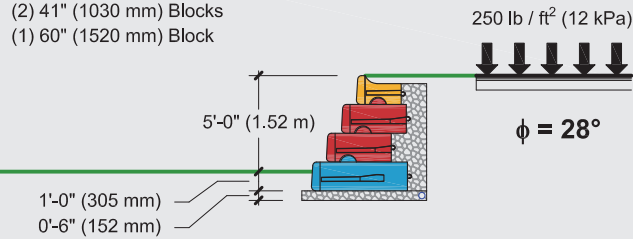

## 5 BLOCK HIGH SECTION

- (1) 28" (710 mm) Top Block
- (2) 41" (1030 mm) Blocks
- (2) 60" (1520 mm) Blocks

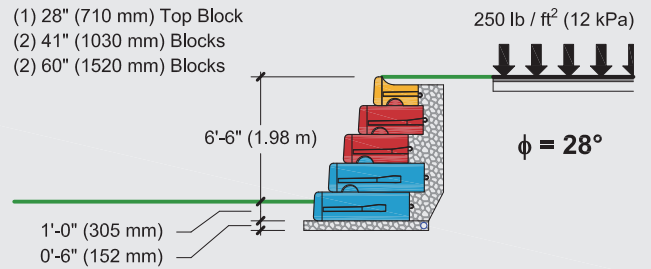

## 6 BLOCK HIGH SECTION

- (1) 28" (710 mm) Top Block
- (1) 41" (1030 mm) Block
- (4) 60" (1520 mm) Blocks

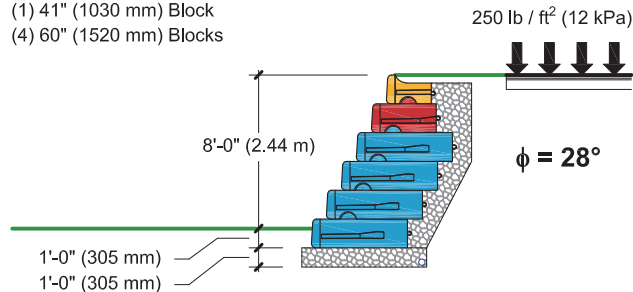

### Legend:

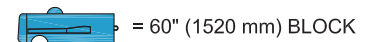
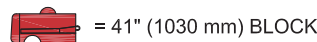
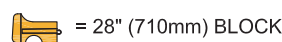

**SEE NOTES AND RECOMMENDED DETAILS AT START OF PRELIMINARY HEIGHT GUIDE.**

9" (230 mm) SETBACK WALLS

ALLOWABLE STRESS DESIGN

# Preliminary Height Guide

$\phi = 28^\circ$  | SILTY SAND or CLAYEY SAND

**LOAD CONDITION C** | 1 : 2.5 BACK SLOPE, NO TOE SLOPE, NO LIVE LOAD SURCHARGE

### 2 BLOCK HIGH SECTION

- (1) 28" (710 mm) Top Block
- (1) 41" (1030 mm) Block

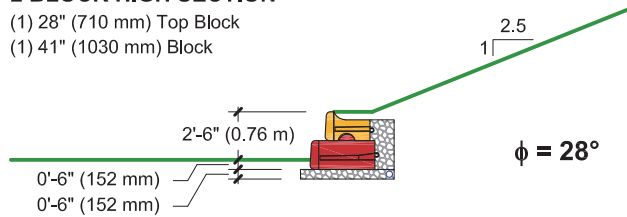

### 3 BLOCK HIGH SECTION

- (1) 28" (710 mm) Top Block
- (1) 41" (1030 mm) Block
- (1) 60" (1520 mm) Block

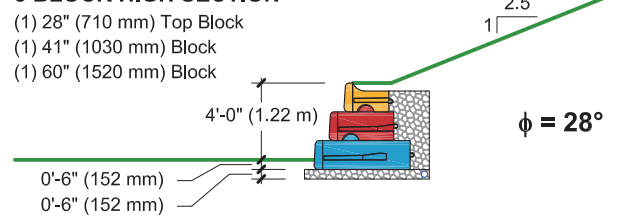

### 4 BLOCK HIGH SECTION

- (1) 28" (710 mm) Top Block
- (3) 60" (1520 mm) Blocks

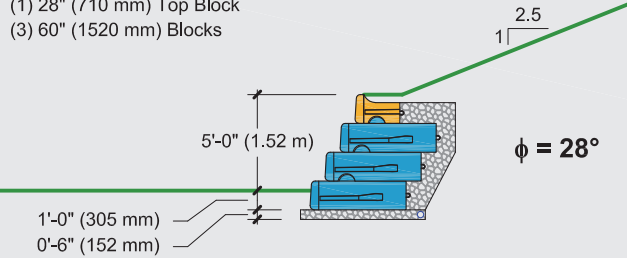

### Legend:

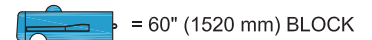
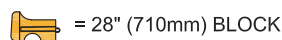

**SEE NOTES AND RECOMMENDED DETAILS AT START OF PRELIMINARY HEIGHT GUIDE.**



Downtown  
3rd Street   
EXIT ONLY

P  
PARKING  
NEXT  
RIGHT





MSE WALLS

## POSITIVE CONNECTION SYSTEM WALLS

34°   DENSE WELL-GRADED SAND <i>or</i> SAND AND GRAVEL.....	130
30°   FINE TO MEDIUM SAND <i>or</i> SILTY SAND .....	158
28°   SILTY SAND <i>or</i> CLAYEY SAND .....	188

# IMPORTANT NOTICE

The design specifications for Redi-Rock® blocks suggest maximum installation heights under certain assumed conditions. These wall heights were calculated using the assumed material properties and loading conditions in the *Design Resource Manual* and will vary from location to location depending on the soil properties and terrain. Since soil conditions and topography vary greatly from site to site, an engineering analysis must be performed for each wall installation.

Because Redi-Rock International does not build the blocks or install the wall system, Redi-Rock International does not assume any responsibility regarding structural stability of any particular block or particular wall system. In addition, Redi-Rock International assumes no responsibility in connection with any injury, death, or property damage claim whatsoever whether asserted against a Lessee, Leasor, Purchaser or others, arising out of or attributable to the operation of or products produced with Redi-Rock International equipment.

# Preliminary Reinforcement Schedule

This preliminary reinforcement schedule has been prepared showing Redi-Rock Mechanically Stabilized Earth (MSE) walls in a variety of assumed conditions. It is intended to give the specifier an idea of what types and lengths of geogrid reinforcement are required to achieve various wall heights in different applications. Redi-Rock 28" (710 mm) wide Positive Connection (PC) System blocks and 12" (305 mm) strips of Mirafi Geogrid are used.

Several assumptions have been made in preparation of the guide. They are listed in the notes below. If these assumptions do not match the wall section under consideration, types and lengths of geogrid reinforcement will vary from what is shown in this guide. All wall sections for construction must be designed by a registered Professional Engineer using the actual conditions of the site.

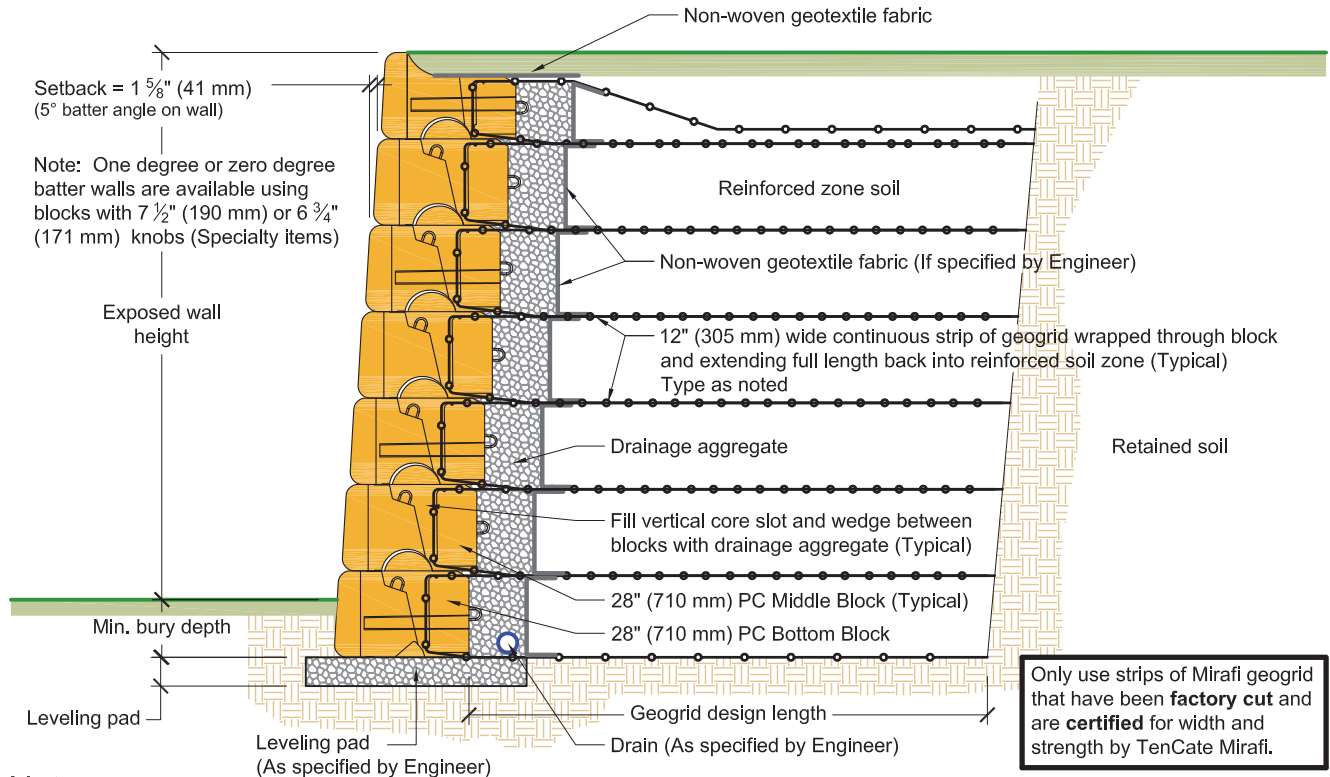

## Notes:

This preliminary reinforcement schedule has been prepared for three different soil types and three different load conditions to demonstrate the type and length of geogrid soil reinforcement needed to construct Redi-Rock PC System MSE walls. **Redi-Rock walls are not limited to these conditions.** Specific wall sections can be designed for different soil and loading conditions.

Unit weight of soil is assumed to be 120 lb/ft<sup>3</sup> (18.85 kN/m<sup>3</sup>) or 130 lb/ft<sup>3</sup> (20.4 kN/m<sup>3</sup>) as noted for each section of this guide.

Design calculations are in general accordance with *AASHTO LRFD Bridge Design Specifications, Customary, 6th Edition* (2012). Load combinations are per AASHTO Table 3.4.1-1. Load factors are per AASHTO Table 3.4.1-2. Resistance factors are per AASHTO Table 11.5.7-1 and Sections 11.5.7, 11.5.8, and 11.6.2.3.

These block selection and height guides were prepared by Redi-Rock International for estimating and conceptual design purposes only. All information is believed to be true and accurate; however, Redi-Rock International assumes no responsibility for the use of these preliminary guides for actual construction. Determination of the suitability of each preliminary guide is the sole responsibility of the user. **Final designs for construction purposes must be performed by a registered Professional Engineer, using the actual conditions of the proposed site.**

This preliminary reinforcement schedule demonstrates geogrid requirements for the soil types as shown. Some agencies may require select backfill material for use in the reinforced soil zone that differ from the material assumed in this guide. Actual geogrid requirements for construction may vary from those shown in this guide depending on site-specific soil parameters.

No seismic or hydrostatic loads were included in this preliminary guide.

Independent barrier design at the top of the wall must be performed for site-specific conditions. Barrier requirements may result in changes to the geogrid reinforcement types and lengths from those shown in this guide.

**Wall stability needs to be verified in the final design for site-specific conditions.**

The wall design shall address both internal and external drainage and shall be evaluated by the Professional Engineer who is responsible for the final wall design.

Backfill material to be compacted to 90% modified proctor density (ASTM D1557).

All Redi-Rock International Wall System Specifications and installation recommendations should be followed.

Construction oversight should be provided on all walls to ensure proper construction according to your detailed design drawings.

Redi-Rock products are manufactured by independently owned, licensed manufacturers. Product offerings will vary between manufacturers. Contact your local manufacturer to determine what products are available for your job.

# Preliminary Reinforcement Schedule

$\phi = 34^\circ$  | DENSE WELL-GRADED SAND or SAND AND GRAVEL

Positive Connection System MSE Walls	SECTION 1 OF 3
Assumed reinforced zone, retained, and foundation soils for this Section	SW, GW
Internal angle of friction	$\phi = 34^\circ$
Unit weight	$\gamma = 130 \text{ lb / ft}^3$ (20.4 kN / m <sup>3</sup> )
Cohesion	$c = 0 \text{ lb / ft}^2$ (0 kPa)

**LOAD CONDITION A** | NO LIVE LOAD SURFACE, NO BACK SLOPE, NO TOE SLOPE.....131

**LOAD CONDITION B** | 250 lb/ft<sup>2</sup> (12 kPa) LIVE LOAD SURCHARGE, NO BACK SLOPE, NO TOE SLOPE.....138

**LOAD CONDITION CR** | 1 : 2 CREST SLOPE, 10' (3.0 m) HIGH, 250 lb/ft<sup>2</sup> (12 kPa) LIVE LOAD SURCHARGE AT CREST, NO TOE SLOPE.....145

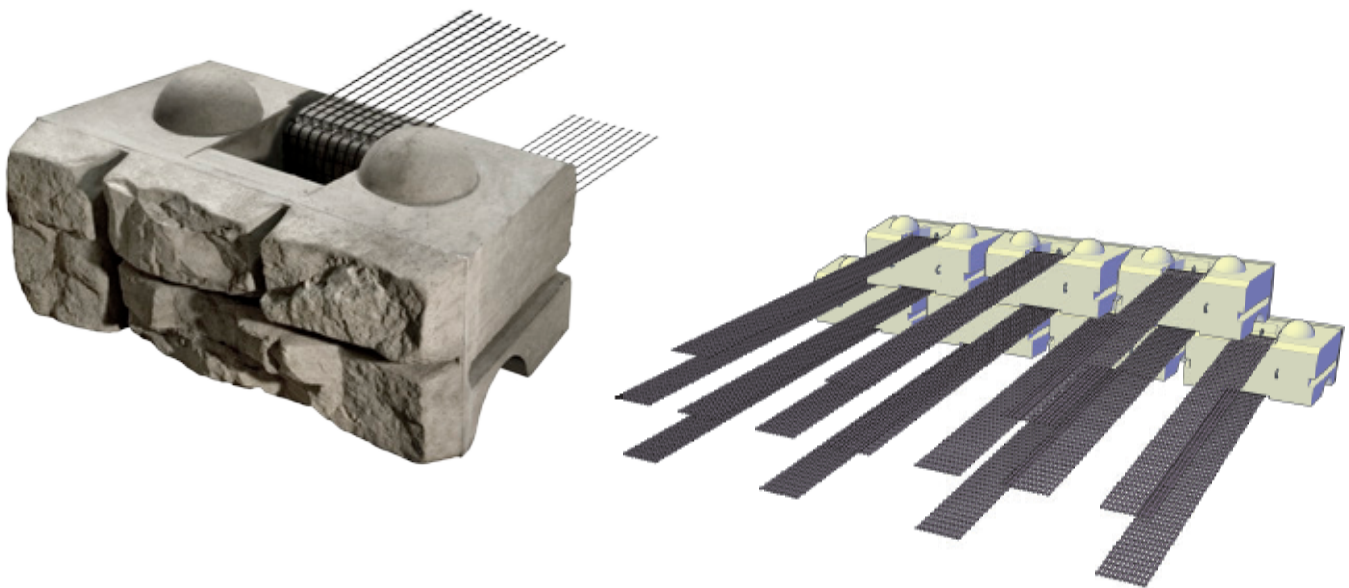

# Preliminary Reinforcement Schedule

$\phi = 34^\circ$  | DENSE WELL-GRADED SAND or SAND AND GRAVEL

**LOAD CONDITION A** | NO LIVE LOAD SURCHARGE, NO BACK SLOPE, NO TOE SLOPE

2 BLOCK SECTION  
(2) 28" (710 mm) Blocks

Geogrid Rolls Required per Wall Length		
Type	Rolls / linear ft	Rolls / linear m
No Geogrid Needed		

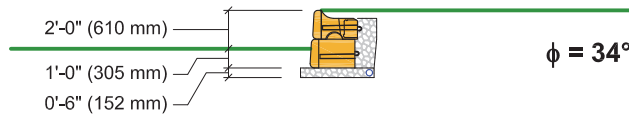

3 BLOCK SECTION  
(3) 28" (710 mm) Blocks

Geogrid Rolls Required per Wall Length		
Type	Rolls / linear ft	Rolls / linear m
No Geogrid Needed		

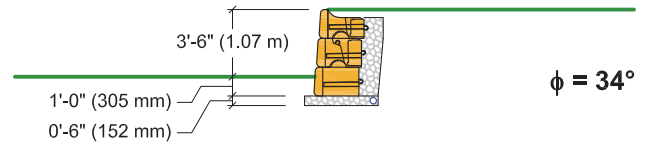

4 BLOCK SECTION  
(4) 28" (710 mm) Blocks

Geogrid Rolls Required per Wall Length		
Type	Rolls / linear ft	Rolls / linear m
No Geogrid Needed		

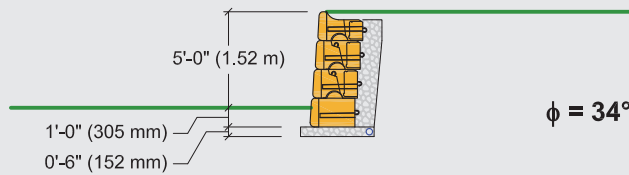

5 BLOCK SECTION  
(5) 28" (710 mm) Blocks

Geogrid Rolls Required per Wall Length		
Type	Rolls / linear ft	Rolls / linear m
No Geogrid Needed		

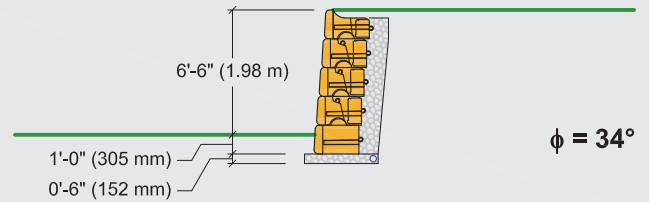

6 BLOCK SECTION  
(4) 28" (710 mm) Blocks  
(1) 41" (1030 mm) Blocks

Geogrid Rolls Required per Wall Length		
Type	Rolls / linear ft	Rolls / linear m
No Geogrid Needed		

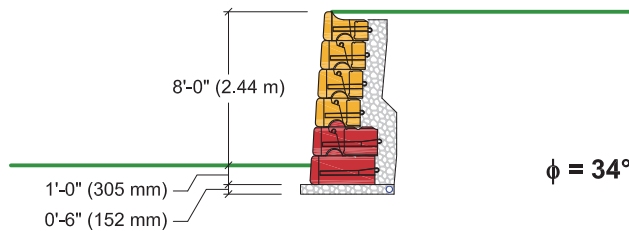

7 BLOCK SECTION  
(7) 28" (710 mm) Blocks

Geogrid Rolls Required per Wall Length		
Type	Rolls / linear ft	Rolls / linear m
5XT	± 0.16	± 0.51

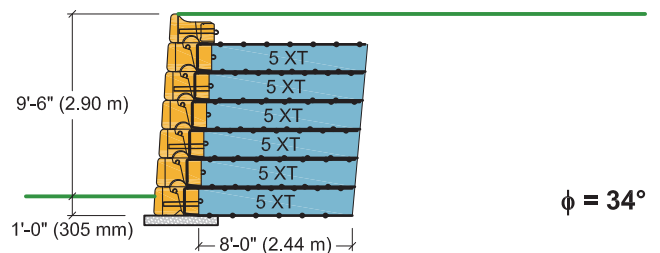

**Legend:**

= 28" (710mm) BLOCK

= 41" (1030 mm) BLOCK

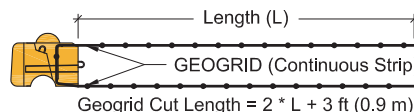

Geogrid shall be 12" (305 mm) wide strips of Mirafi geogrid, type as noted. Geogrid shall be **factory cut** and **certified** for width and strength by TenCate Mirafi.

**SEE NOTES AND RECOMMENDED DETAILS AT START OF PRELIM. REINFORCEMENT SCHEDULE.**

# Preliminary Reinforcement Schedule

$\phi = 34^\circ$  | DENSE WELL-GRADED SAND or SAND AND GRAVEL

**LOAD CONDITION A** | NO LIVE LOAD SURCHARGE, NO BACK SLOPE, NO TOE SLOPE

8 BLOCK SECTION  
(8) 28" (710 mm) Blocks

Geogrid Rolls Required per Wall Length		
Type	Rolls / linear ft	Rolls / linear m
5XT	± 0.20	± 0.66

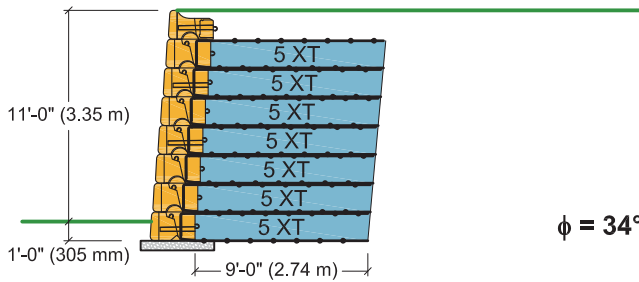

9 BLOCK SECTION  
(9) 28" (710 mm) Blocks

Geogrid Rolls Required per Wall Length		
Type	Rolls / linear ft	Rolls / linear m
5XT	± 0.23	± 0.75
8XT	± 0.03	± 0.11

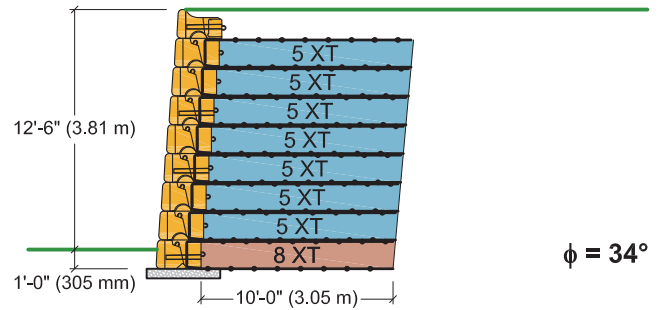

10 BLOCK SECTION  
(10) 28" (710 mm) Blocks

Geogrid Rolls Required per Wall Length		
Type	Rolls / linear ft	Rolls / linear m
5XT	± 0.23	± 0.75
8XT	± 0.07	± 0.21

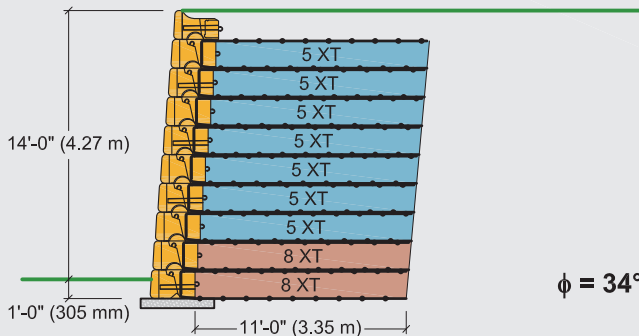

11 BLOCK SECTION  
(11) 28" (710 mm) Blocks

Geogrid Rolls Required per Wall Length		
Type	Rolls / linear ft	Rolls / linear m
5XT	± 0.26	± 0.85
8XT	± 0.11	± 0.37

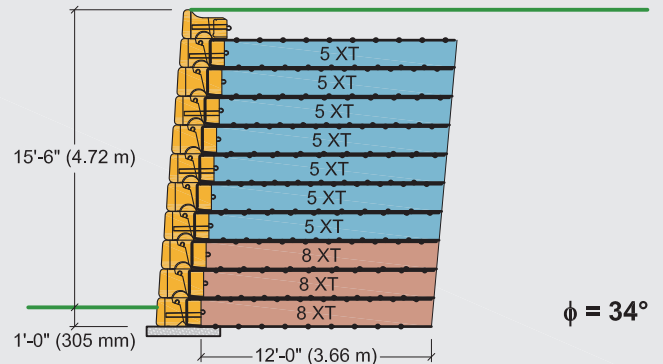

**Legend:**

= 28" (710mm) BLOCK

= 41" (1030 mm) BLOCK

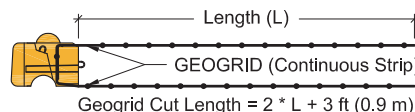

Geogrid shall be 12" (305 mm) wide strips of Mirafi geogrid, type as noted. Geogrid shall be **factory cut** and **certified** for width and strength by TenCate Mirafi.

**SEE NOTES AND RECOMMENDED DETAILS AT START OF PRELIM. REINFORCEMENT SCHEDULE.**

# Preliminary Reinforcement Schedule

$\phi = 34^\circ$  | DENSE WELL-GRADED SAND or SAND AND GRAVEL

**LOAD CONDITION A** | NO LIVE LOAD SURCHARGE, NO BACK SLOPE, NO TOE SLOPE

12 BLOCK SECTION  
(12) 28" (710 mm) Blocks

Geogrid Rolls Required per Wall Length		
Type	Rolls / linear ft	Rolls / linear m
5XT	± 0.30	± 1.00
8XT	± 0.17	± 0.57

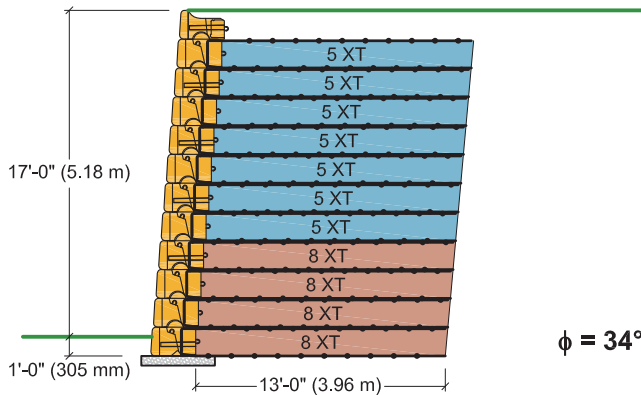

13 BLOCK SECTION  
(13) 28" (710 mm) Blocks

Geogrid Rolls Required per Wall Length		
Type	Rolls / linear ft	Rolls / linear m
5XT	± 0.30	± 1.00
8XT	± 0.22	± 0.71

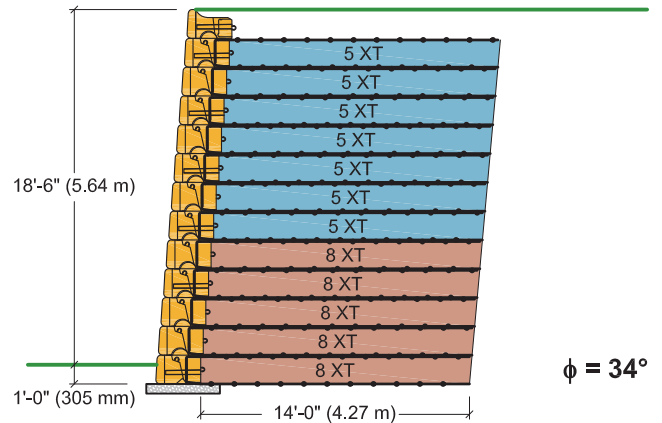

14 BLOCK SECTION  
(14) 28" (710 mm) Blocks

Geogrid Rolls Required per Wall Length		
Type	Rolls / linear ft	Rolls / linear m
5XT	± 0.30	± 1.00
10XT	± 0.26	± 0.85

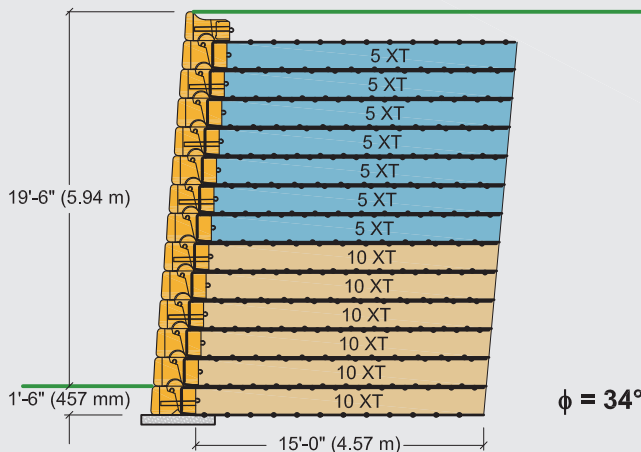

15 BLOCK SECTION  
(15) 28" (710 mm) Blocks

Geogrid Rolls Required per Wall Length		
Type	Rolls / linear ft	Rolls / linear m
5XT	± 0.36	± 1.19
10XT	± 0.36	± 1.19

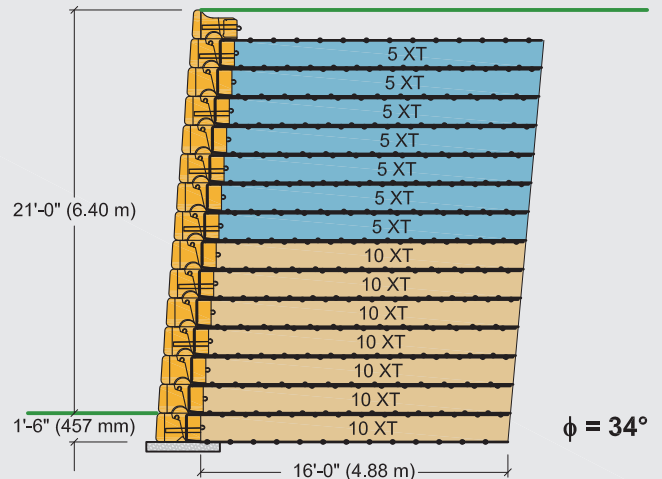

**Legend:**

= 28" (710mm) BLOCK

= 41" (1030 mm) BLOCK

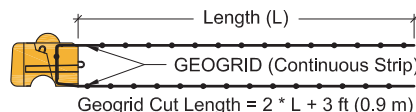

Geogrid shall be 12" (305 mm) wide strips of Mirafi geogrid, type as noted. Geogrid shall be **factory cut** and **certified** for width and strength by TenCate Mirafi.

**SEE NOTES AND RECOMMENDED DETAILS AT START OF PRELIM. REINFORCEMENT SCHEDULE.**

# Preliminary Reinforcement Schedule

$\phi = 34^\circ$  | DENSE WELL-GRADED SAND or SAND AND GRAVEL

**LOAD CONDITION A** | NO LIVE LOAD SURCHARGE, NO BACK SLOPE, NO TOE SLOPE

16 BLOCK SECTION  
(16) 28" (710 mm) Blocks

Geogrid Rolls Required per Wall Length		
Type	Rolls / linear ft	Rolls / linear m
5XT	± 0.36	± 1.19
10XT	± 0.42	± 1.37

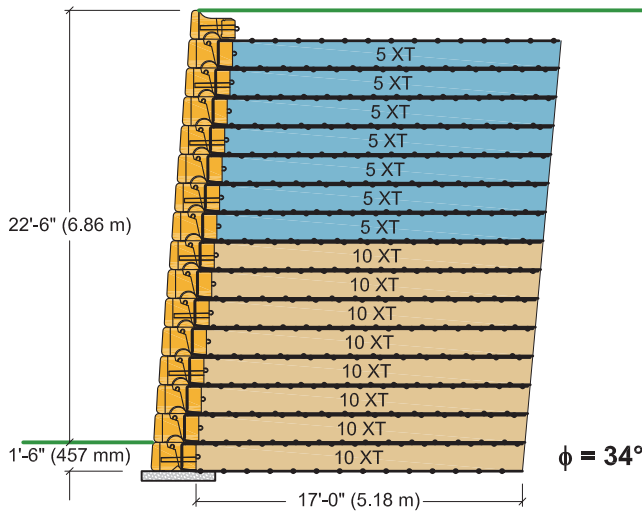

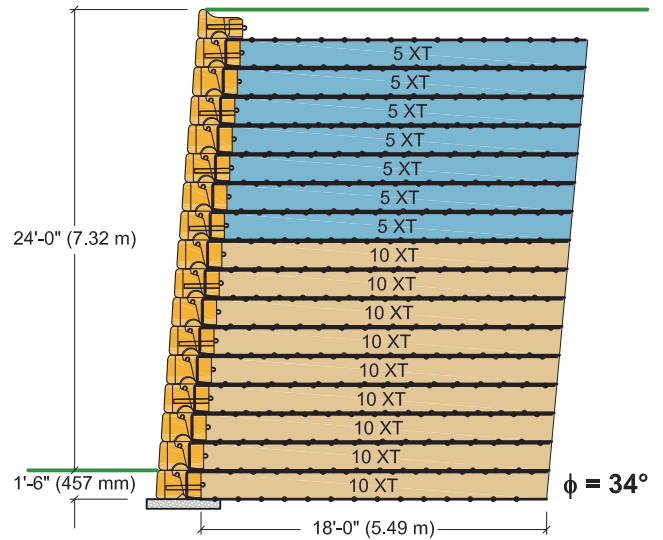

17 BLOCK SECTION  
(17) 28" (710 mm) Blocks

Geogrid Rolls Required per Wall Length		
Type	Rolls / linear ft	Rolls / linear m
5XT	± 0.36	± 1.19
10XT	± 0.47	± 1.54



**Legend:**

-  = 28" (710mm) BLOCK
-  = 41" (1030 mm) BLOCK

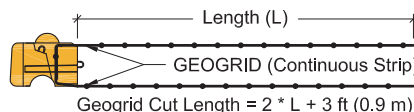

Geogrid shall be 12" (305 mm) wide strips of Mirafi geogrid, type as noted. Geogrid shall be **factory cut** and **certified** for width and strength by TenCate Mirafi.

**SEE NOTES AND RECOMMENDED DETAILS AT START OF PRELIM. REINFORCEMENT SCHEDULE.**

# Preliminary Reinforcement Schedule

$\phi = 34^\circ$  | DENSE WELL-GRADED SAND or SAND AND GRAVEL



**LOAD CONDITION A** | NO LIVE LOAD SURCHARGE, NO BACK SLOPE, NO TOE SLOPE

18 BLOCK SECTION  
(18) 28" (710 mm) Blocks

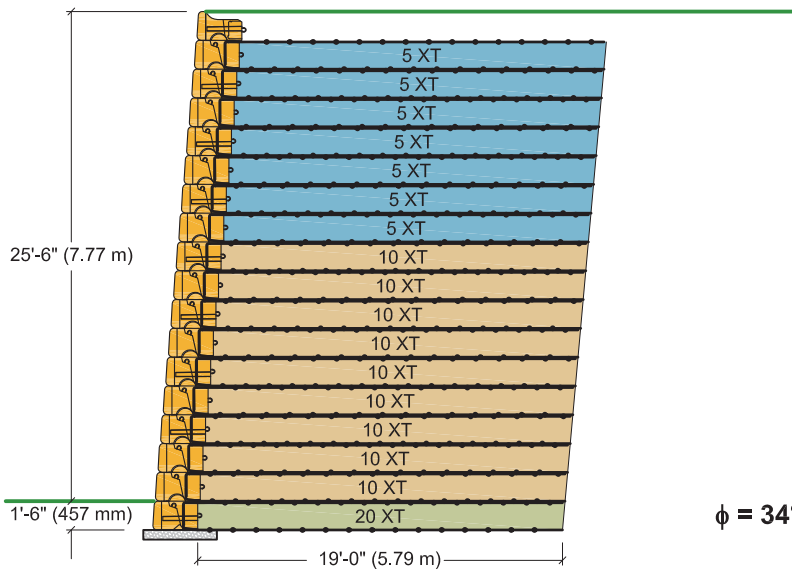
Geogrid Rolls Required per Wall Length		
Type	Rolls / linear ft	Rolls / linear m
5XT	± 0.46	± 1.49
10XT	± 0.59	± 1.92
20XT	± 0.07	± 0.21



**Legend:**

-  = 28" (710mm) BLOCK
-  = 41" (1030 mm) BLOCK

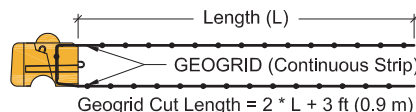

Geogrid shall be 12" (305 mm) wide strips of Mirafi geogrid, type as noted. Geogrid shall be **factory cut** and **certified** for width and strength by TenCate Mirafi.

**SEE NOTES AND RECOMMENDED DETAILS AT START OF PRELIM. REINFORCEMENT SCHEDULE.**

# Preliminary Reinforcement Schedule

$\phi = 34^\circ$  | DENSE WELL-GRADED SAND or SAND AND GRAVEL



**LOAD CONDITION A** | NO LIVE LOAD SURCHARGE, NO BACK SLOPE, NO TOE SLOPE

19 BLOCK SECTION  
(19) 28" (710 mm) Blocks

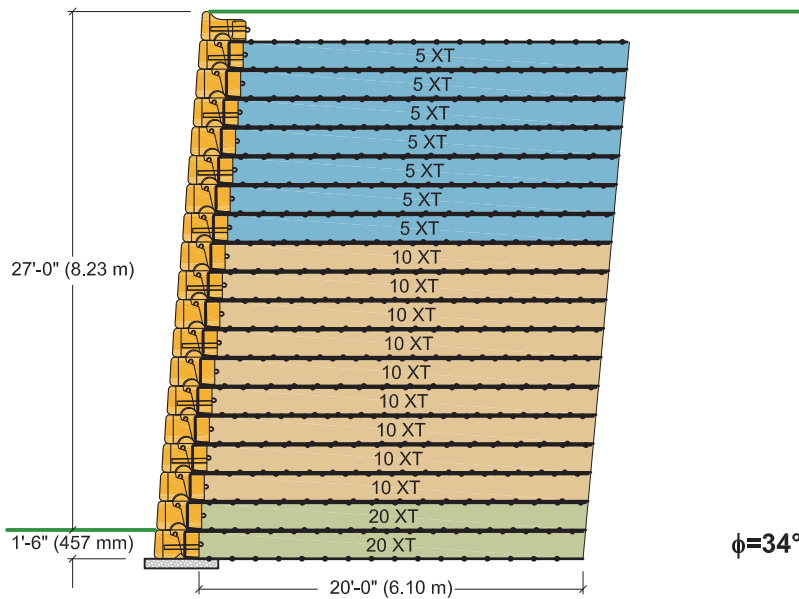
Geogrid Rolls Required per Wall Length		
Type	Rolls / linear ft	Rolls / linear m
5XT	± 0.46	± 1.49
10XT	± 0.59	± 1.92
20XT	± 0.13	± 0.43



**Legend:**

-  = 28" (710mm) BLOCK
-  = 41" (1030 mm) BLOCK

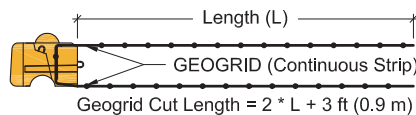

Geogrid shall be 12" (305 mm) wide strips of Mirafi geogrid, type as noted. Geogrid shall be **factory cut** and **certified** for width and strength by TenCate Mirafi.

**SEE NOTES AND RECOMMENDED DETAILS AT START OF PRELIM. REINFORCEMENT SCHEDULE.**

# Preliminary Reinforcement Schedule

$\phi = 34^\circ$  | DENSE WELL-GRADED SAND or SAND AND GRAVEL



**LOAD CONDITION A** | NO LIVE LOAD SURCHARGE, NO BACK SLOPE, NO TOE SLOPE

20 BLOCK SECTION \*  
(20) 28" (710 mm) Blocks

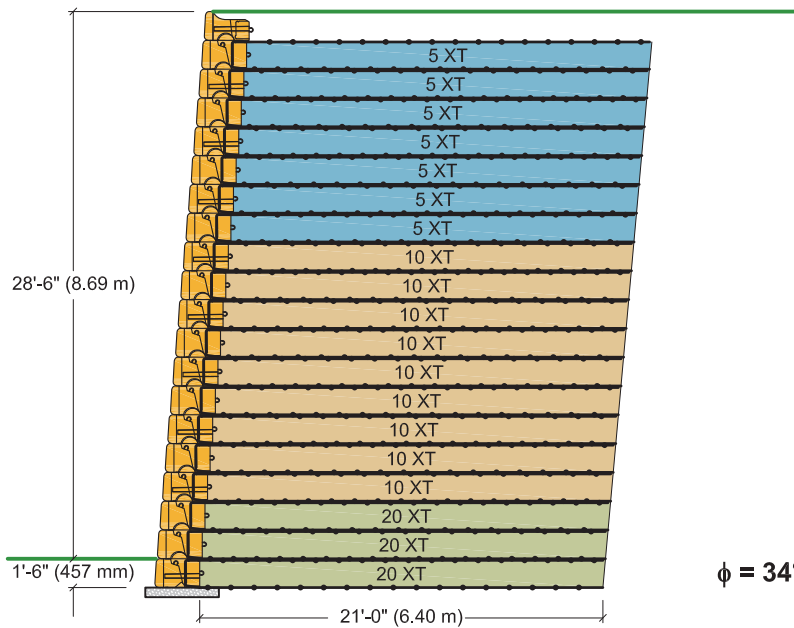
Geogrid Rolls Required per Wall Length		
Type	Rolls / linear ft	Rolls / linear m
5XT	± 0.46	± 1.49
10XT	± 0.59	± 1.92
20XT	± 0.20	± 0.64



**Legend:**

-  = 28" (710mm) BLOCK
-  = 41" (1030 mm) BLOCK

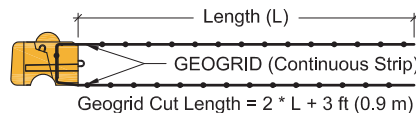

Geogrid shall be 12" (305 mm) wide strips of Mirafi geogrid, type as noted. Geogrid shall be **factory cut** and **certified** for width and strength by TenCate Mirafi.

**\* Not tall enough? You can build significantly taller walls with the Redi-Rock PC System...we just had to stop the preliminary sections somewhere. Talk to your Engineer or give us a call for more info.**

**SEE NOTES AND RECOMMENDED DETAILS AT START OF PRELIM. REINFORCEMENT SCHEDULE.**

# Preliminary Reinforcement Schedule

$\phi = 34^\circ$  | DENSE WELL-GRADED SAND or SAND AND GRAVEL

**LOAD CONDITION B** | 250 lb/ft<sup>2</sup> (12 kPa) LIVE LOAD SURCHARGE, NO BACK SLOPE, NO TOE SLOPE

**2 BLOCK SECTION**  
 (1) 28" (710 mm) Block  
 (1) 41" (1030 mm) Block

Geogrid Rolls Required per Wall Length		
Type	Rolls / linear ft	Rolls / linear m
No Geogrid Needed		

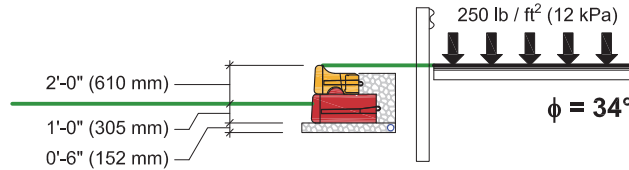

**3 BLOCK SECTION**  
 (1) 28" (710 mm) Block  
 (2) 41" (1030 mm) Blocks

Geogrid Rolls Required per Wall Length		
Type	Rolls / linear ft	Rolls / linear m
No Geogrid Needed		

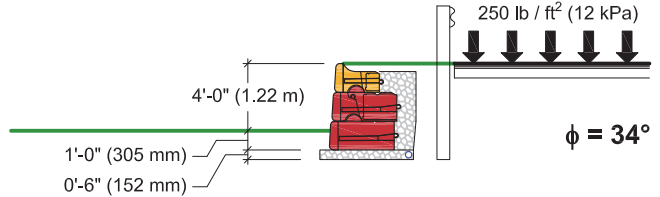

**4 BLOCK SECTION**  
 (1) 28" (710 mm) Block  
 (3) 41" (1030 mm) Blocks

Geogrid Rolls Required per Wall Length		
Type	Rolls / linear ft	Rolls / linear m
No Geogrid Needed		

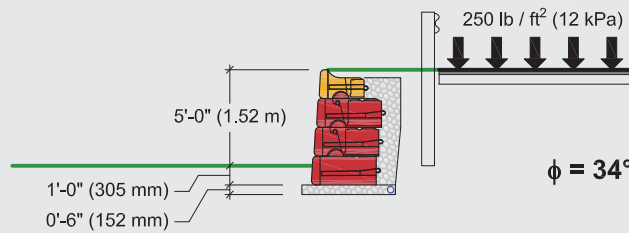

**5 BLOCK SECTION**  
 (5) 28" (710 mm) Blocks

Geogrid Rolls Required per Wall Length		
Type	Rolls / linear ft	Rolls / linear m
5XT	± 0.14	± 0.47

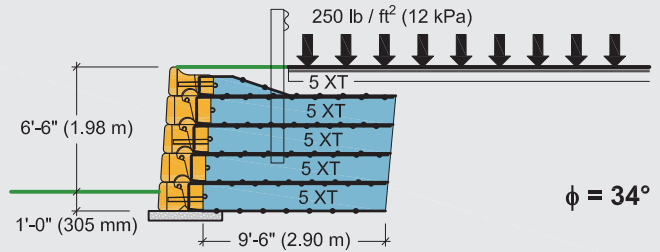

**6 BLOCK SECTION**  
 (6) 28" (710 mm) Blocks

Geogrid Rolls Required per Wall Length		
Type	Rolls / linear ft	Rolls / linear m
5XT	± 0.20	± 0.64

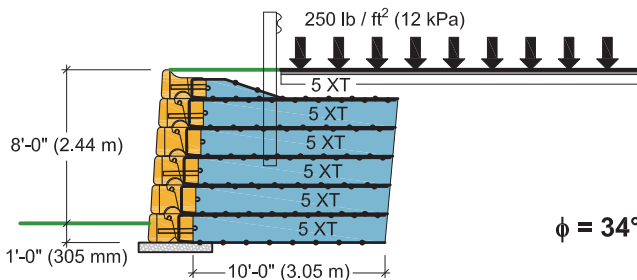

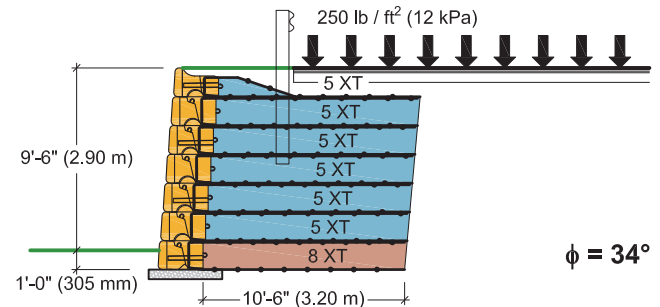

**7 BLOCK SECTION**  
 (7) 28" (710 mm) Blocks

Geogrid Rolls Required per Wall Length		
Type	Rolls / linear ft	Rolls / linear m
5XT	± 0.20	± 0.64
8XT	± 0.03	± 0.11



**Legend:**

-  = 28" (710mm) BLOCK
-  = 41" (1030 mm) BLOCK

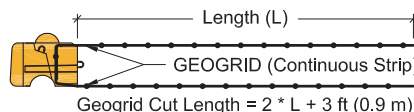

Geogrid shall be 12" (305 mm) wide strips of Mirafi geogrid, type as noted. Geogrid shall be **factory cut** and **certified** for width and strength by TenCate Mirafi.

**SEE NOTES AND RECOMMENDED DETAILS AT START OF PRELIM. REINFORCEMENT SCHEDULE.**

# Preliminary Reinforcement Schedule

$\phi = 34^\circ$  | DENSE WELL-GRADED SAND or SAND AND GRAVEL

**LOAD CONDITION B** | 250 lb/ft<sup>2</sup> (12 kPa) LIVE LOAD SURCHARGE, NO BACK SLOPE, NO TOE SLOPE

8 BLOCK SECTION  
(8) 28" (710 mm) Blocks

Geogrid Rolls Required per Wall Length		
Type	Rolls / linear ft	Rolls / linear m
5XT	± 0.20	± 0.64
8XT	± 0.07	± 0.21

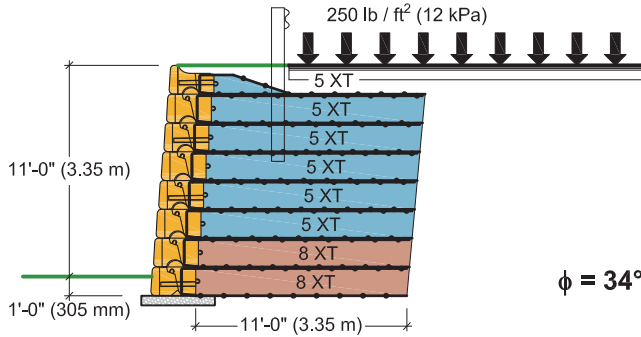

9 BLOCK SECTION  
(9) 28" (710 mm) Blocks

Geogrid Rolls Required per Wall Length		
Type	Rolls / linear ft	Rolls / linear m
5XT	± 0.22	± 0.73
8XT	± 0.11	± 0.37

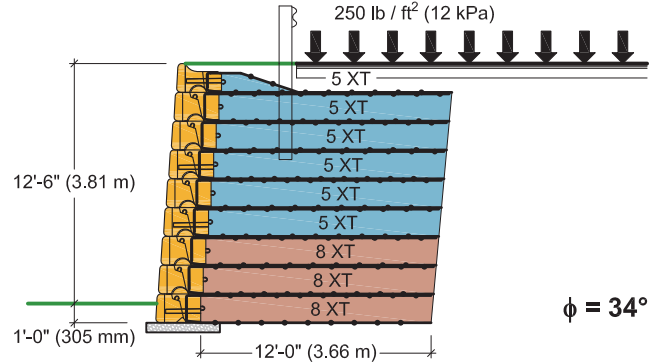

10 BLOCK SECTION  
(10) 28" (710 mm) Blocks

Geogrid Rolls Required per Wall Length		
Type	Rolls / linear ft	Rolls / linear m
5XT	± 0.22	± 0.73
8XT	± 0.15	± 0.49

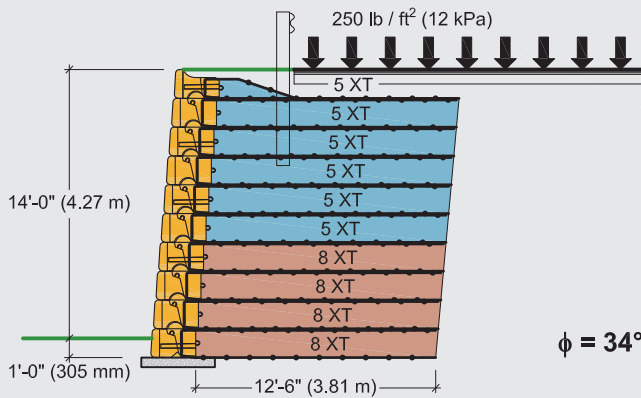

11 BLOCK SECTION  
(11) 28" (710 mm) Blocks

Geogrid Rolls Required per Wall Length		
Type	Rolls / linear ft	Rolls / linear m
5XT	± 0.26	± 0.85
8XT	± 0.22	± 0.71

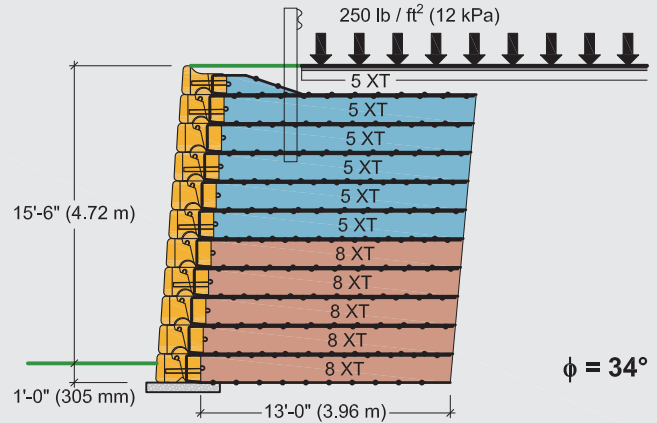

**Legend:**

= 28" (710mm) BLOCK

= 41" (1030 mm) BLOCK

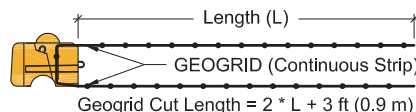

Geogrid shall be 12" (305 mm) wide strips of Mirafi geogrid, type as noted. Geogrid shall be **factory cut** and **certified** for width and strength by TenCate Mirafi.

**SEE NOTES AND RECOMMENDED DETAILS AT START OF PRELIM. REINFORCEMENT SCHEDULE.**

# Preliminary Reinforcement Schedule

$\phi = 34^\circ$  | DENSE WELL-GRADED SAND or SAND AND GRAVEL

**LOAD CONDITION B** | 250 lb/ft<sup>2</sup> (12 kPa) LIVE LOAD SURCHARGE, NO BACK SLOPE, NO TOE SLOPE

12 BLOCK SECTION  
(12) 28" (710 mm) Blocks

Geogrid Rolls Required per Wall Length		
Type	Rolls / linear ft	Rolls / linear m
5XT	± 0.26	± 0.85
8XT	± 0.26	± 0.85

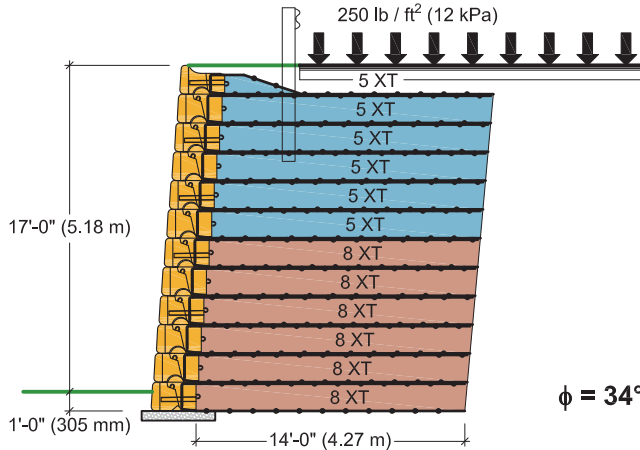

13 BLOCK SECTION  
(13) 28" (710 mm) Blocks

Geogrid Rolls Required per Wall Length		
Type	Rolls / linear ft	Rolls / linear m
5XT	± 0.26	± 0.85
10XT	± 0.30	± 1.00

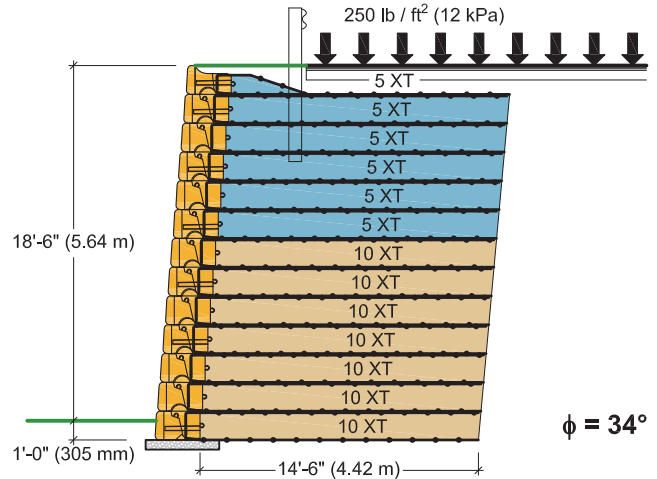

14 BLOCK SECTION  
(14) 28" (710 mm) Blocks

Geogrid Rolls Required per Wall Length		
Type	Rolls / linear ft	Rolls / linear m
5XT	± 0.26	± 0.85
10XT	± 0.35	± 1.14

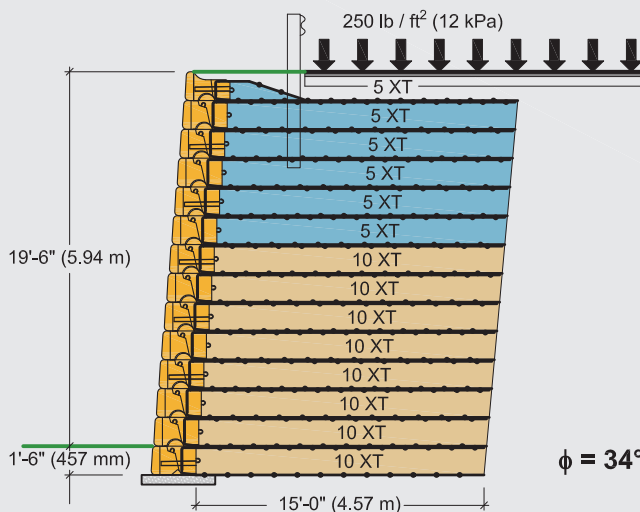

15 BLOCK SECTION  
(15) 28" (710 mm) Blocks

Geogrid Rolls Required per Wall Length		
Type	Rolls / linear ft	Rolls / linear m
5XT	± 0.31	± 1.02
10XT	± 0.47	± 1.54

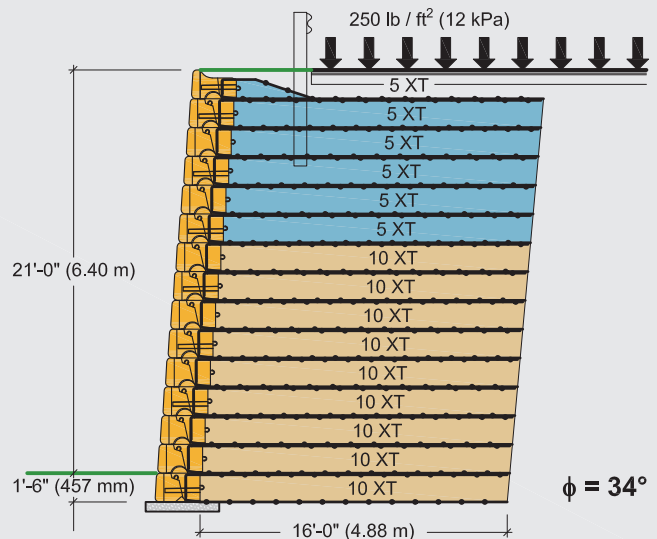

**Legend:**

= 28" (710mm) BLOCK

= 41" (1030 mm) BLOCK

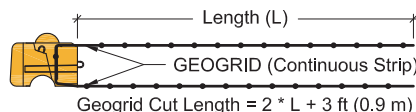

Geogrid shall be 12" (305 mm) wide strips of Mirafi geogrid, type as noted. Geogrid shall be **factory cut** and **certified** for width and strength by TenCate Mirafi.

**SEE NOTES AND RECOMMENDED DETAILS AT START OF PRELIM. REINFORCEMENT SCHEDULE.**

# Preliminary Reinforcement Schedule

$\phi = 34^\circ$  | DENSE WELL-GRADED SAND or SAND AND GRAVEL

**LOAD CONDITION B** | 250 lb/ft<sup>2</sup> (12 kPa) LIVE LOAD SURCHARGE, NO BACK SLOPE, NO TOE SLOPE

16 BLOCK SECTION  
(16) 28" (710 mm) Blocks

Geogrid Rolls Required per Wall Length		
Type	Rolls / linear ft	Rolls / linear m
5XT	± 0.31	± 1.02
10XT	± 0.47	± 1.54
20XT	± 0.05	± 0.17

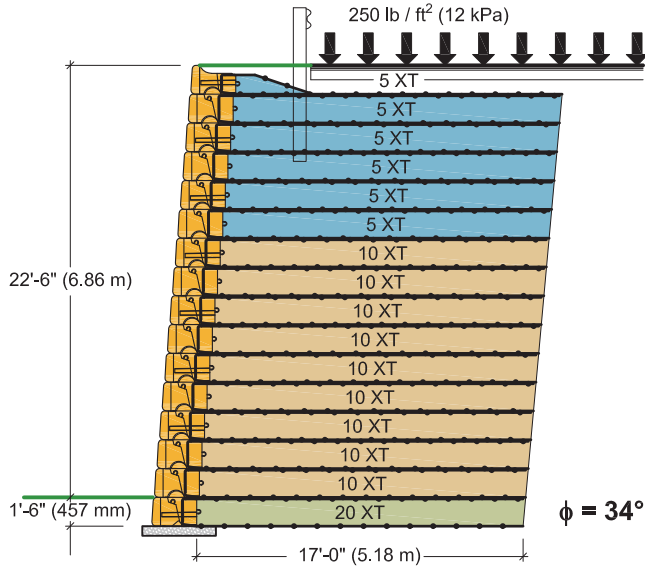

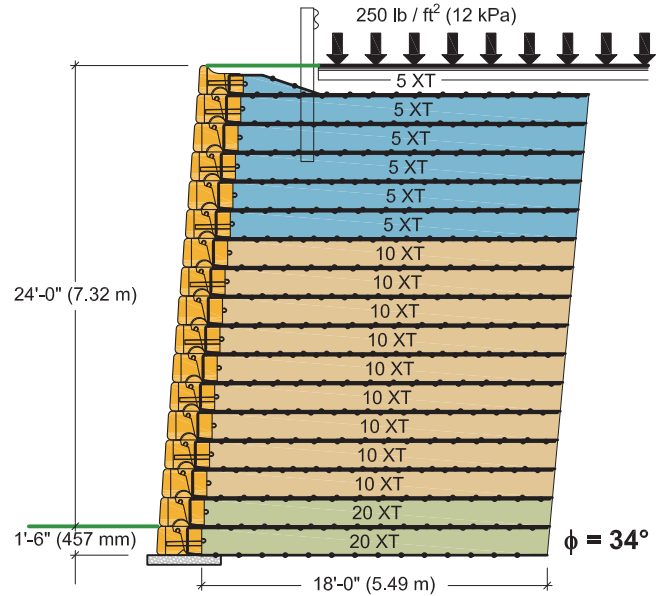

17 BLOCK SECTION  
(17) 28" (710 mm) Blocks

Geogrid Rolls Required per Wall Length		
Type	Rolls / linear ft	Rolls / linear m
5XT	± 0.31	± 1.02
10XT	± 0.47	± 1.54
20XT	± 0.10	± 0.34



**Legend:**

-  = 28" (710mm) BLOCK
-  = 41" (1030 mm) BLOCK

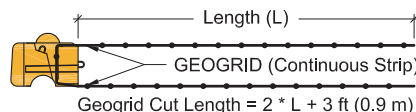

Geogrid shall be 12" (305 mm) wide strips of Mirafi geogrid, type as noted. Geogrid shall be **factory cut** and **certified** for width and strength by TenCate Mirafi.

**SEE NOTES AND RECOMMENDED DETAILS AT START OF PRELIM. REINFORCEMENT SCHEDULE.**

# Preliminary Reinforcement Schedule

$\phi = 34^\circ$  | DENSE WELL-GRADED SAND or SAND AND GRAVEL



**LOAD CONDITION B** | 250 lb/ft<sup>2</sup> (12 kPa) LIVE LOAD SURCHARGE, NO BACK SLOPE, NO TOE SLOPE

18 BLOCK SECTION  
(18) 28" (710 mm) Blocks

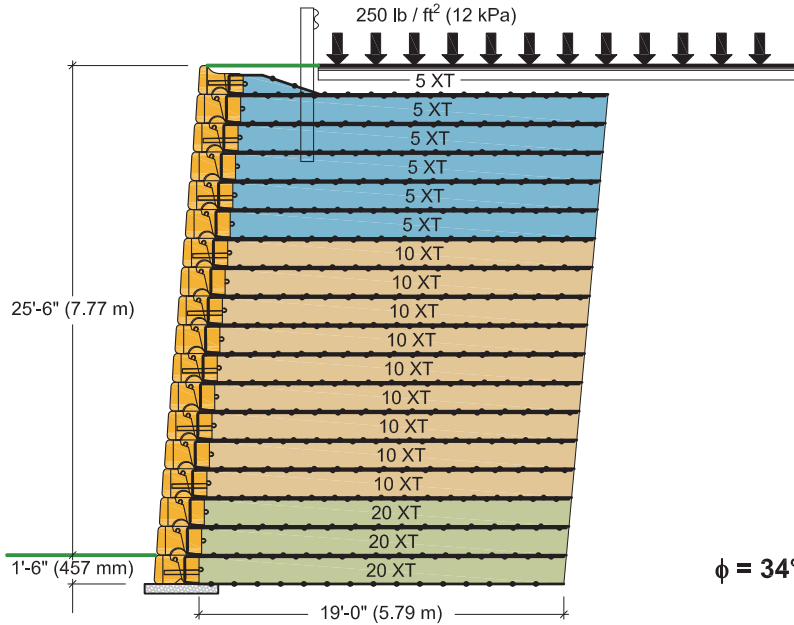
Geogrid Rolls Required per Wall Length		
Type	Rolls / linear ft	Rolls / linear m
5XT	± 0.39	± 1.28
10XT	± 0.59	± 1.92
20XT	± 0.20	± 0.64



**Legend:**

-  = 28" (710mm) BLOCK
-  = 41" (1030 mm) BLOCK

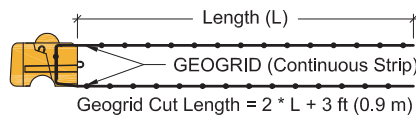

Geogrid shall be 12" (305 mm) wide strips of Mirafi geogrid, type as noted. Geogrid shall be **factory cut** and **certified** for width and strength by TenCate Mirafi.

**SEE NOTES AND RECOMMENDED DETAILS AT START OF PRELIM. REINFORCEMENT SCHEDULE.**

# Preliminary Reinforcement Schedule

$\phi = 34^\circ$  | DENSE WELL-GRADED SAND or SAND AND GRAVEL



**LOAD CONDITION B** | 250 lb/ft<sup>2</sup> (12 kPa) LIVE LOAD SURCHARGE, NO BACK SLOPE, NO TOE SLOPE

19 BLOCK SECTION  
(19) 28" (710 mm) Blocks

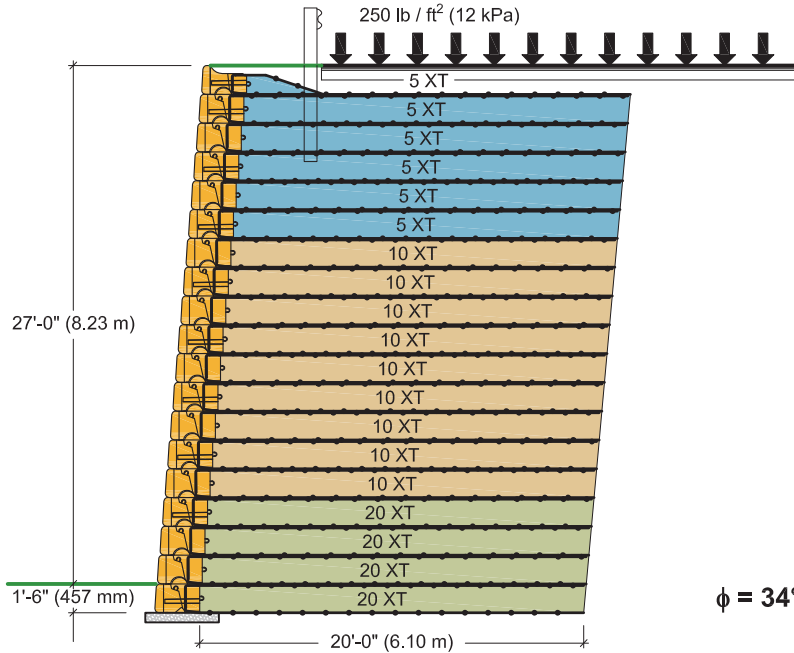
Geogrid Rolls Required per Wall Length		
Type	Rolls / linear ft	Rolls / linear m
5XT	± 0.39	± 1.28
10XT	± 0.59	± 1.92
20XT	± 0.26	± 0.85



**Legend:**

-  = 28" (710mm) BLOCK
-  = 41" (1030 mm) BLOCK

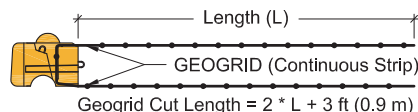

Geogrid shall be 12" (305 mm) wide strips of Mirafi geogrid, type as noted. Geogrid shall be **factory cut** and **certified** for width and strength by TenCate Mirafi.

**SEE NOTES AND RECOMMENDED DETAILS AT START OF PRELIM. REINFORCEMENT SCHEDULE.**

# Preliminary Reinforcement Schedule

$\phi = 34^\circ$  | DENSE WELL-GRADED SAND or SAND AND GRAVEL



**LOAD CONDITION B** | 250 lb/ft<sup>2</sup> (12 kPa) LIVE LOAD SURCHARGE, NO BACK SLOPE, NO TOE SLOPE

20 BLOCK SECTION \*  
(20) 28" (710 mm) Blocks

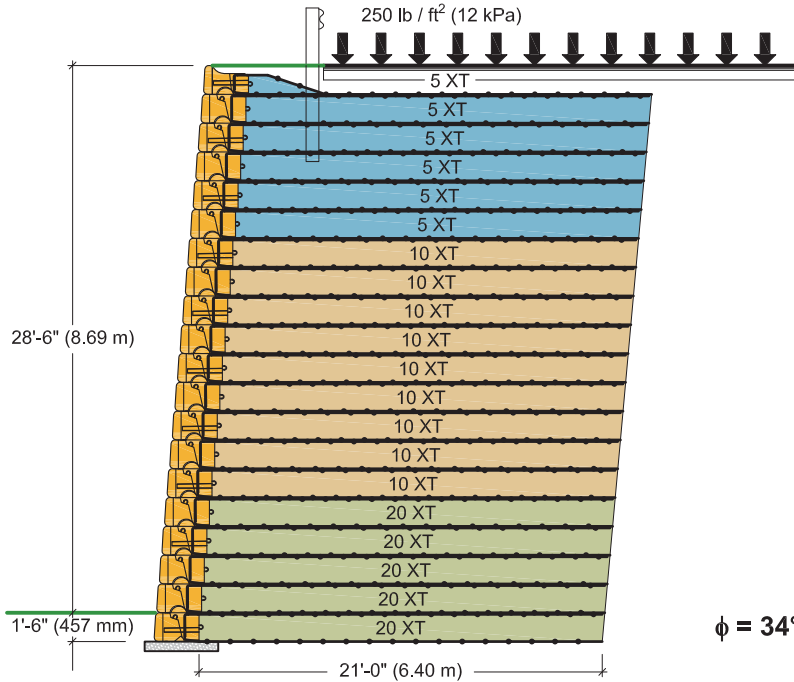
Geogrid Rolls Required per Wall Length		
Type	Rolls / linear ft	Rolls / linear m
5XT	± 0.39	± 1.28
10XT	± 0.59	± 1.92
20XT	± 0.33	± 1.07



**Legend:**

-  = 28" (710mm) BLOCK
-  = 41" (1030 mm) BLOCK

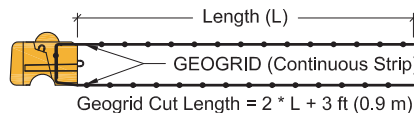

Geogrid shall be 12" (305 mm) wide strips of Mirafi geogrid, type as noted. Geogrid shall be **factory cut** and **certified** for width and strength by TenCate Mirafi.

**\* Not tall enough? You can build significantly taller walls with the Redi-Rock PC System...we just had to stop the preliminary sections somewhere. Talk to your Engineer or give us a call for more info.**

**SEE NOTES AND RECOMMENDED DETAILS AT START OF PRELIM. REINFORCEMENT SCHEDULE.**

# Preliminary Reinforcement Schedule

$\phi = 34^\circ$  | DENSE WELL-GRADED SAND or SAND AND GRAVEL

**LOAD CONDITION CR** | 1 : 2 CREST SLOPE, 10' (3.0 m) HIGH, 250 lb/ft<sup>2</sup> (12 kPa) SURCHARGE AT CREST, NO TOE SLOPE

2 BLOCK HIGH SECTION  
(2) 28" (710 mm) Blocks

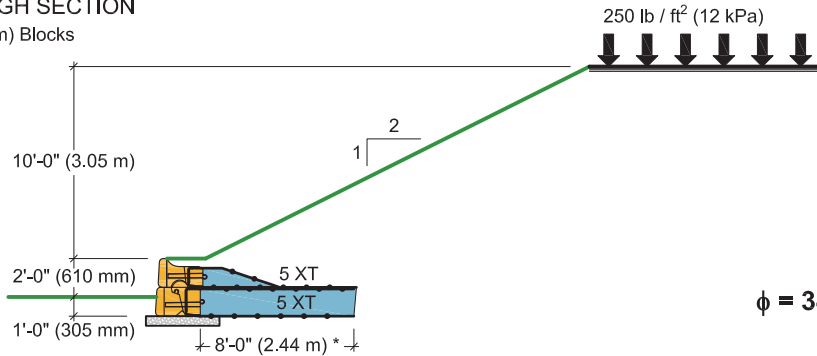

Geogrid Rolls Required per Wall Length		
Type	Rolls / linear ft	Rolls / linear m
5XT	± 0.05	± 0.17

3 BLOCK HIGH SECTION  
(3) 28" (710 mm) Blocks

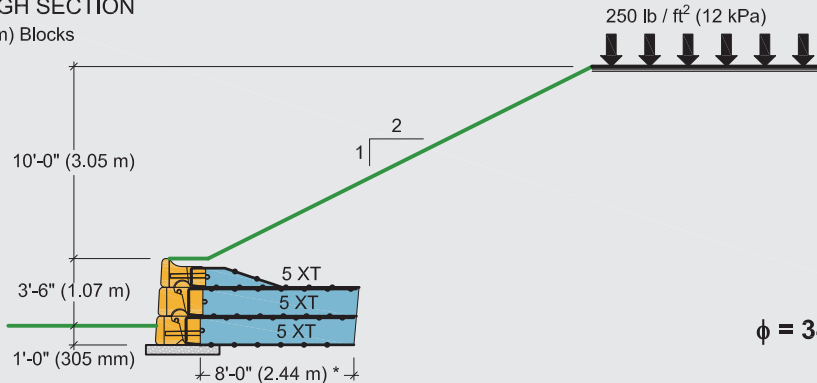

Geogrid Rolls Required per Wall Length		
Type	Rolls / linear ft	Rolls / linear m
5XT	± 0.08	± 0.26

4 BLOCK HIGH SECTION  
(4) 28" (710 mm) Blocks

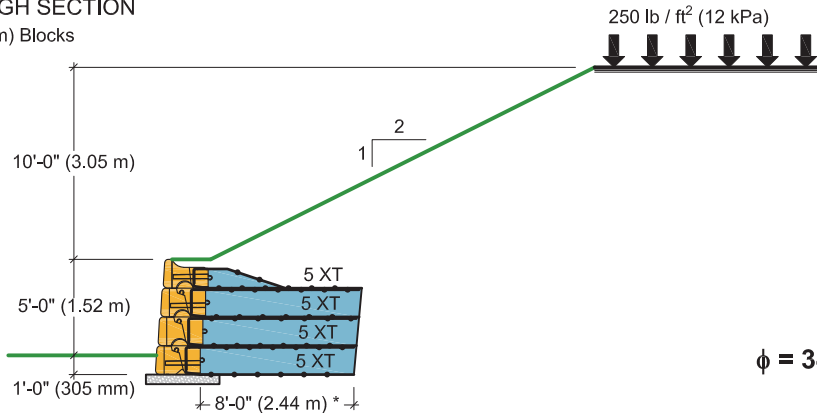

Geogrid Rolls Required per Wall Length		
Type	Rolls / linear ft	Rolls / linear m
5XT	± 0.10	± 0.34

**Legend:**

= 28" (710mm) BLOCK

= 41" (1030 mm) BLOCK

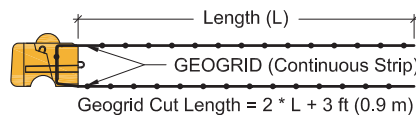

Geogrid shall be 12" (305 mm) wide strips of Mirafi geogrid, type as noted. Geogrid shall be **factory cut** and **certified** for width and strength by TenCate Mirafi.

\* Geogrid length primarily controlled by global stability. Length will change with crest height.

**SEE NOTES AND RECOMMENDED DETAILS AT START OF PRELIM. REINFORCEMENT SCHEDULE.**

# Preliminary Reinforcement Schedule

$\phi = 34^\circ$  | DENSE WELL-GRADED SAND or SAND AND GRAVEL

**LOAD CONDITION CR** | 1 : 2 CREST SLOPE, 10' (3.0 m) HIGH, 250 lb/ft<sup>2</sup> (12 kPa) SURCHARGE AT CREST, NO TOE SLOPE

5 BLOCK HIGH SECTION  
(5) 28" (710 mm) Blocks

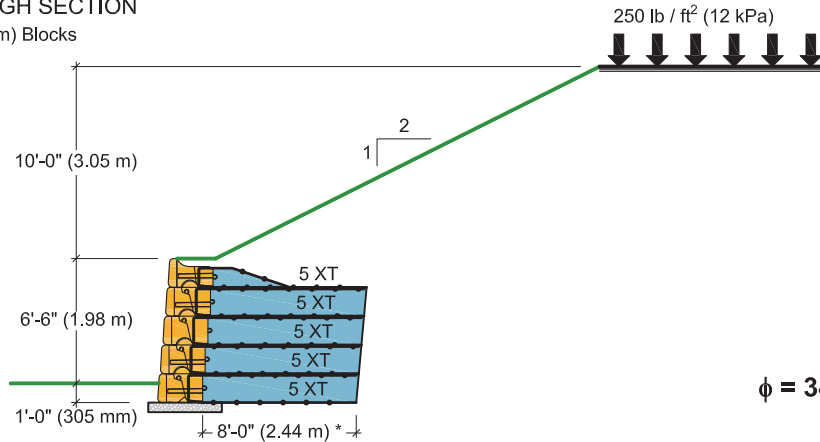

Geogrid Rolls Required per Wall Length		
Type	Rolls / linear ft	Rolls / linear m
5XT	± 0.13	± 0.43

6 BLOCK HIGH SECTION  
(6) 28" (710 mm) Blocks

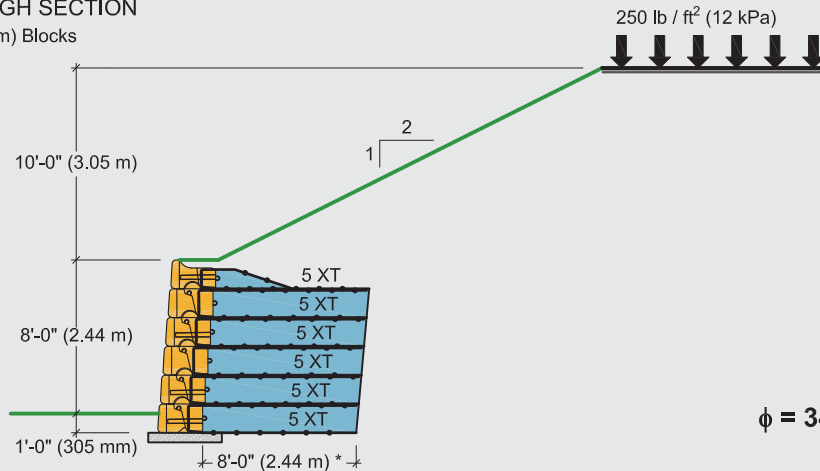

Geogrid Rolls Required per Wall Length		
Type	Rolls / linear ft	Rolls / linear m
5XT	± 0.16	± 0.51

**Legend:**

= 28" (710mm) BLOCK

= 41" (1030 mm) BLOCK

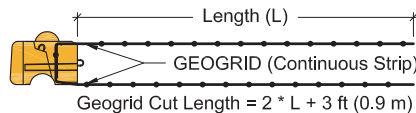

Geogrid shall be 12" (305 mm) wide strips of Mirafi geogrid, type as noted. Geogrid shall be **factory cut** and **certified** for width and strength by TenCate Mirafi.

**\* Geogrid length primarily controlled by global stability. Length will change with crest height.**

**SEE NOTES AND RECOMMENDED DETAILS AT START OF PRELIM. REINFORCEMENT SCHEDULE.**

# Preliminary Reinforcement Schedule

$\phi = 34^\circ$  | DENSE WELL-GRADED SAND or SAND AND GRAVEL

**LOAD CONDITION CR** | 1 : 2 CREST SLOPE, 10' (3.0 m) HIGH, 250 lb/ft<sup>2</sup> (12 kPa) SURCHARGE AT CREST, NO TOE SLOPE

7 BLOCK HIGH SECTION  
(7) 28" (710 mm) Blocks

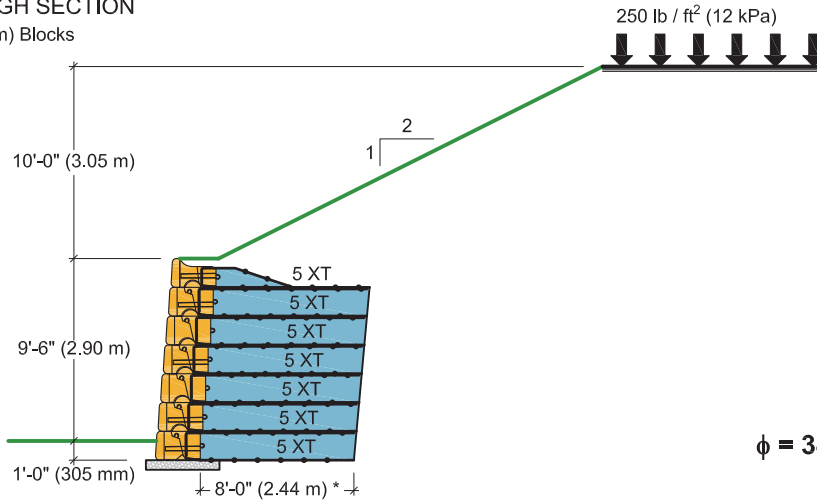

Geogrid Rolls Required per Wall Length		
Type	Rolls / linear ft	Rolls / linear m
5XT	± 0.18	± 0.60

$\phi = 34^\circ$

8 BLOCK HIGH SECTION  
(8) 28" (710 mm) Blocks

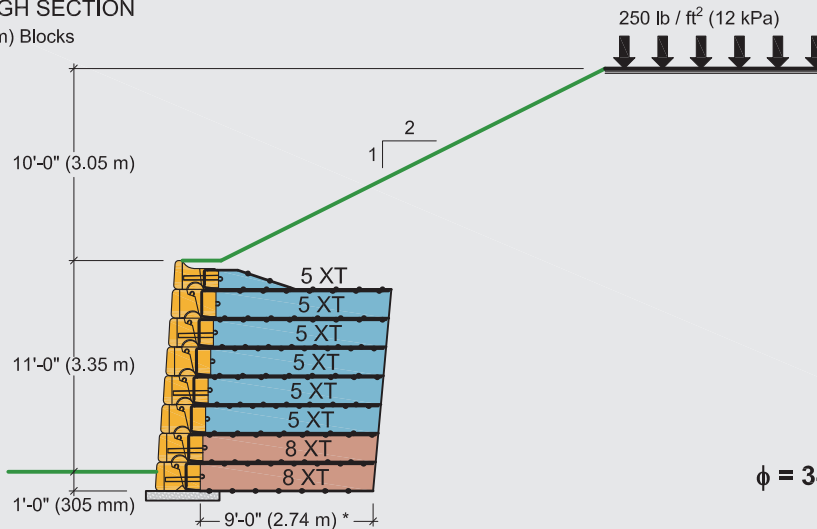

Geogrid Rolls Required per Wall Length		
Type	Rolls / linear ft	Rolls / linear m
5XT	± 0.17	± 0.57
8XT	± 0.06	± 0.19

$\phi = 34^\circ$

**Legend:**

= 28" (710mm) BLOCK

= 41" (1030 mm) BLOCK

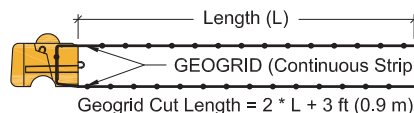

Geogrid shall be 12" (305 mm) wide strips of Mirafi geogrid, type as noted. Geogrid shall be **factory cut** and **certified** for width and strength by TenCate Mirafi.

**\* Geogrid length primarily controlled by global stability. Length will change with crest height.**

**SEE NOTES AND RECOMMENDED DETAILS AT START OF PRELIM. REINFORCEMENT SCHEDULE.**

# Preliminary Reinforcement Schedule

$\phi = 34^\circ$  | DENSE WELL-GRADED SAND or SAND AND GRAVEL

**LOAD CONDITION CR** | 1 : 2 CREST SLOPE, 10' (3.0 m) HIGH, 250 lb/ft<sup>2</sup> (12 kPa) SURCHARGE AT CREST, NO TOE SLOPE

9 BLOCK HIGH SECTION  
(9) 28" (710 mm) Blocks

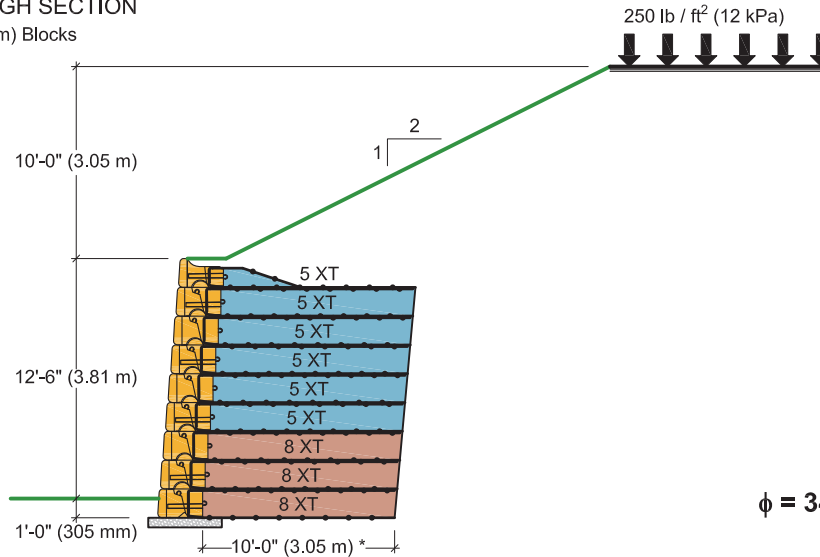

Geogrid Rolls Required per Wall Length		
Type	Rolls / linear ft	Rolls / linear m
5XT	± 0.20	± 0.64
8XT	± 0.10	± 0.32

$\phi = 34^\circ$

10 BLOCK HIGH SECTION  
(10) 28" (710 mm) Blocks

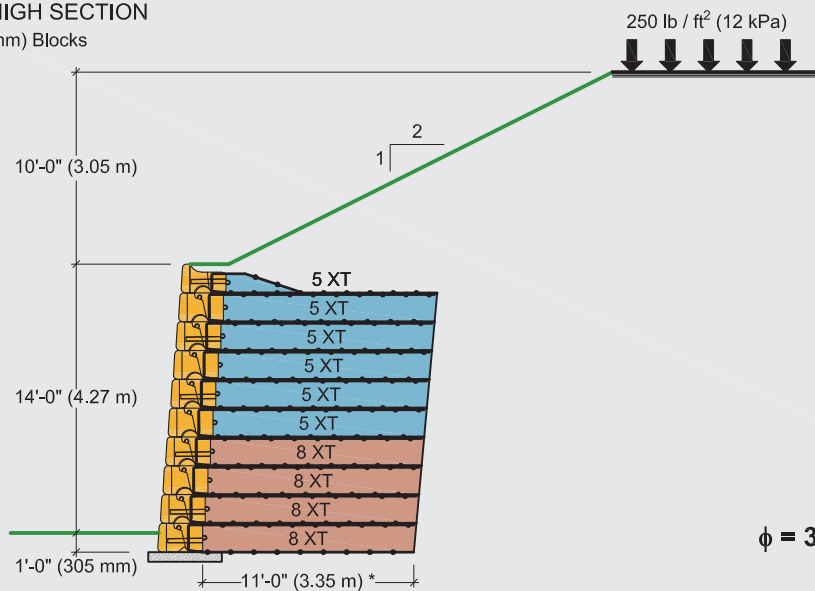

Geogrid Rolls Required per Wall Length		
Type	Rolls / linear ft	Rolls / linear m
5XT	± 0.20	± 0.64
8XT	± 0.13	± 0.43

$\phi = 34^\circ$

**Legend:**

= 28" (710mm) BLOCK

= 41" (1030 mm) BLOCK

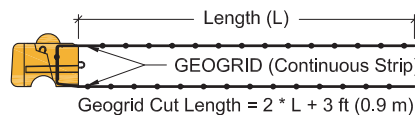

Geogrid shall be 12" (305 mm) wide strips of Mirafi geogrid, type as noted. Geogrid shall be **factory cut** and **certified** for width and strength by TenCate Mirafi.

**\* Geogrid length primarily controlled by global stability. Length will change with crest height.**

**SEE NOTES AND RECOMMENDED DETAILS AT START OF PRELIM. REINFORCEMENT SCHEDULE.**

# Preliminary Reinforcement Schedule

$\phi = 34^\circ$  | DENSE WELL-GRADED SAND or SAND AND GRAVEL

**LOAD CONDITION CR** | 1 : 2 CREST SLOPE, 10' (3.0 m) HIGH, 250 lb/ft<sup>2</sup> (12 kPa) SURCHARGE AT CREST, NO TOE SLOPE

11 BLOCK HIGH SECTION  
(11) 28" (710 mm) Blocks

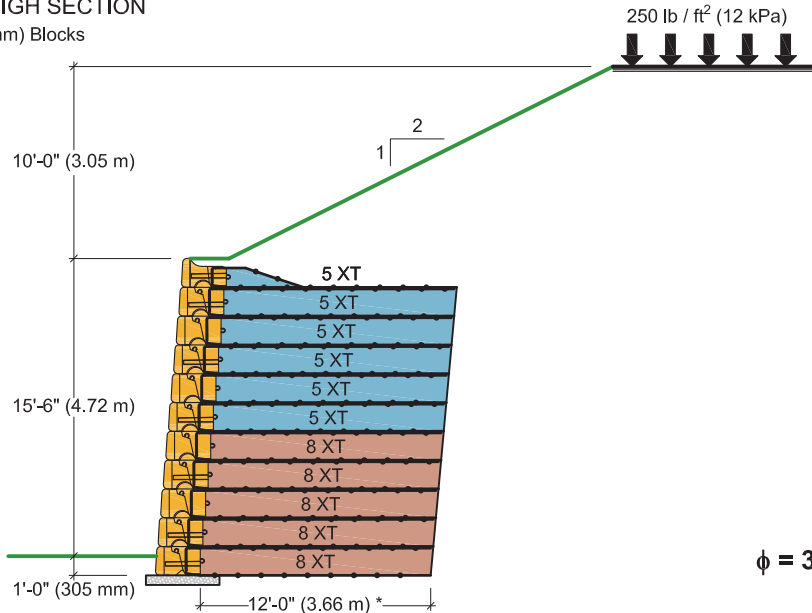

Geogrid Rolls Required per Wall Length		
Type	Rolls / linear ft	Rolls / linear m
5XT	± 0.22	± 0.73
8XT	± 0.19	± 0.61

$\phi = 34^\circ$

12 BLOCK HIGH SECTION  
(12) 28" (710 mm) Blocks

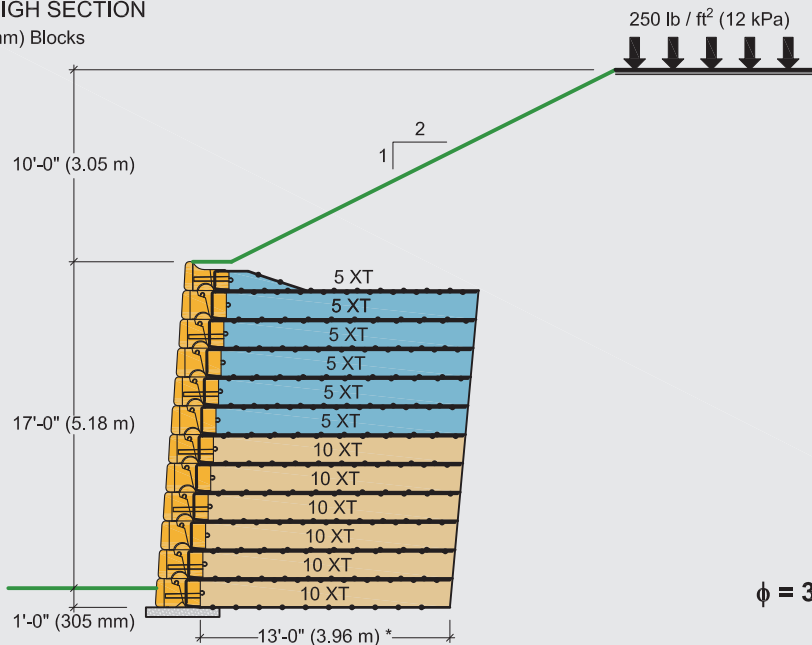

Geogrid Rolls Required per Wall Length		
Type	Rolls / linear ft	Rolls / linear m
5XT	± 0.26	± 0.85
10XT	± 0.26	± 0.85

$\phi = 34^\circ$

**Legend:**

= 28" (710mm) BLOCK

= 41" (1030 mm) BLOCK

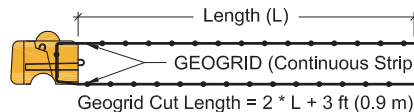

Geogrid shall be 12" (305 mm) wide strips of Mirafi geogrid, type as noted. Geogrid shall be **factory cut** and **certified** for width and strength by TenCate Mirafi.

\* **Geogrid length primarily controlled by global stability. Length will change with crest height.**

**SEE NOTES AND RECOMMENDED DETAILS AT START OF PRELIM. REINFORCEMENT SCHEDULE.**

# Preliminary Reinforcement Schedule

$\phi = 34^\circ$  | DENSE WELL-GRADED SAND or SAND AND GRAVEL

**LOAD CONDITION CR** | 1 : 2 CREST SLOPE, 10' (3.0 m) HIGH, 250 lb/ft<sup>2</sup> (12 kPa) SURCHARGE AT CREST, NO TOE SLOPE

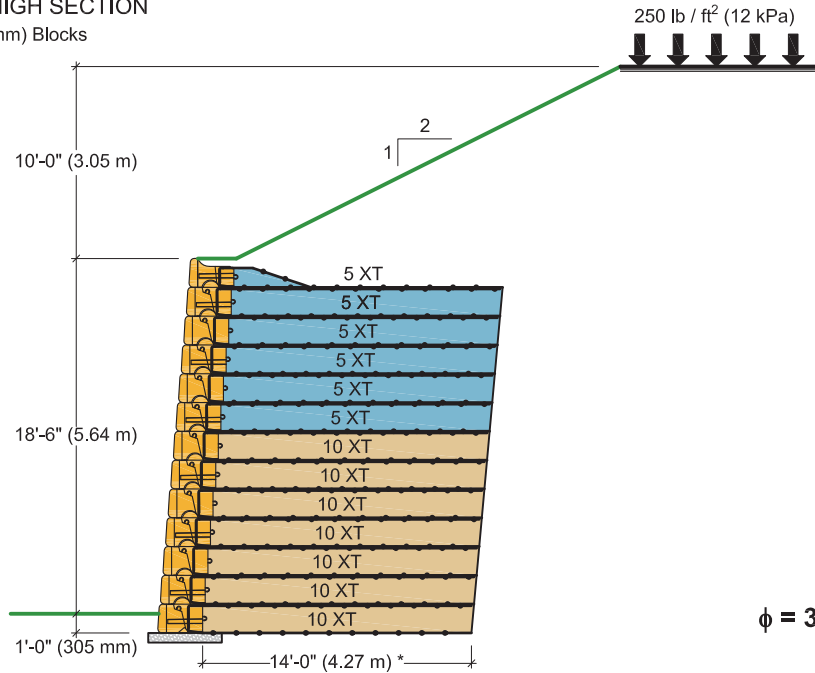

13 BLOCK HIGH SECTION  
(13) 28" (710 mm) Blocks



Geogrid Rolls Required per Wall Length		
Type	Rolls / linear ft	Rolls / linear m
5XT	± 0.26	± 0.85
10XT	± 0.30	± 1.00

$\phi = 34^\circ$

**Legend:**

-  = 28" (710mm) BLOCK
-  = 41" (1030 mm) BLOCK

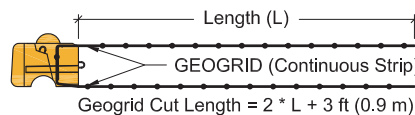

Geogrid shall be 12" (305 mm) wide strips of Mirafi geogrid, type as noted. Geogrid shall be **factory cut** and **certified** for width and strength by TenCate Mirafi.

**\* Geogrid length primarily controlled by global stability. Length will change with crest height.**

**SEE NOTES AND RECOMMENDED DETAILS AT START OF PRELIM. REINFORCEMENT SCHEDULE.**

# Preliminary Reinforcement Schedule

$\phi = 34^\circ$  | DENSE WELL-GRADED SAND or SAND AND GRAVEL

**LOAD CONDITION CR** | 1 : 2 CREST SLOPE, 10' (3.0 m) HIGH, 250 lb/ft<sup>2</sup> (12 kPa) SURCHARGE AT CREST, NO TOE SLOPE

14 BLOCK HIGH SECTION  
(14) 28" (710 mm) Blocks

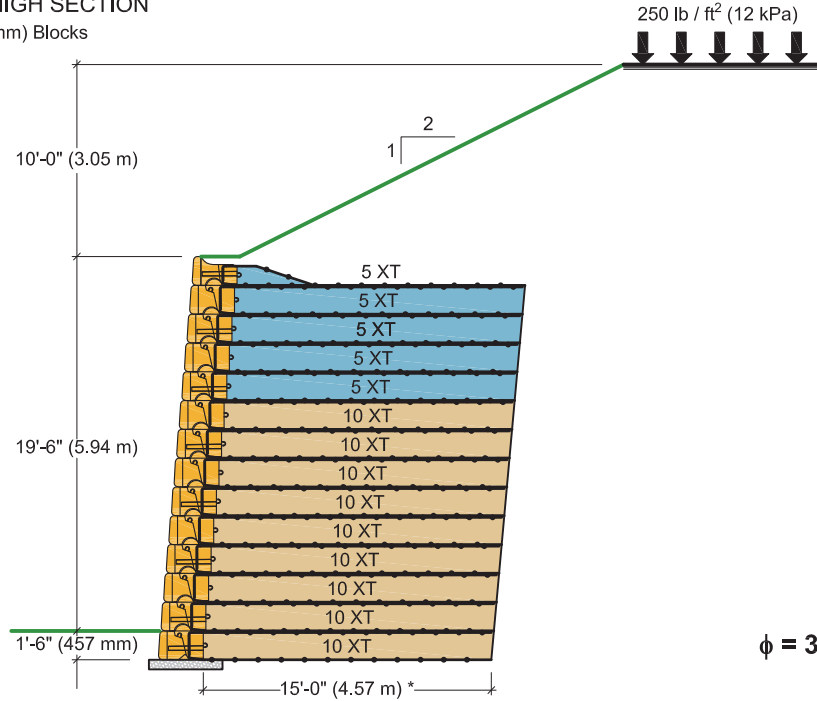

Geogrid Rolls Required per Wall Length		
Type	Rolls / linear ft	Rolls / linear m
5XT	± 0.22	± 0.71
10XT	± 0.39	± 1.28

$\phi = 34^\circ$

**Legend:**

= 28" (710mm) BLOCK

= 41" (1030 mm) BLOCK

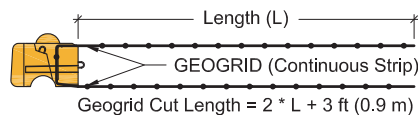

Geogrid shall be 12" (305 mm) wide strips of Mirafi geogrid, type as noted. Geogrid shall be **factory cut** and **certified** for width and strength by TenCate Mirafi.

**\* Geogrid length primarily controlled by global stability. Length will change with crest height.**

**SEE NOTES AND RECOMMENDED DETAILS AT START OF PRELIM. REINFORCEMENT SCHEDULE.**

# Preliminary Reinforcement Schedule

$\phi = 34^\circ$  | DENSE WELL-GRADED SAND or SAND AND GRAVEL

**LOAD CONDITION CR** | 1 : 2 CREST SLOPE, 10' (3.0 m) HIGH, 250 lb/ft<sup>2</sup> (12 kPa) SURCHARGE AT CREST, NO TOE SLOPE

15 BLOCK HIGH SECTION  
(15) 28" (710 mm) Blocks

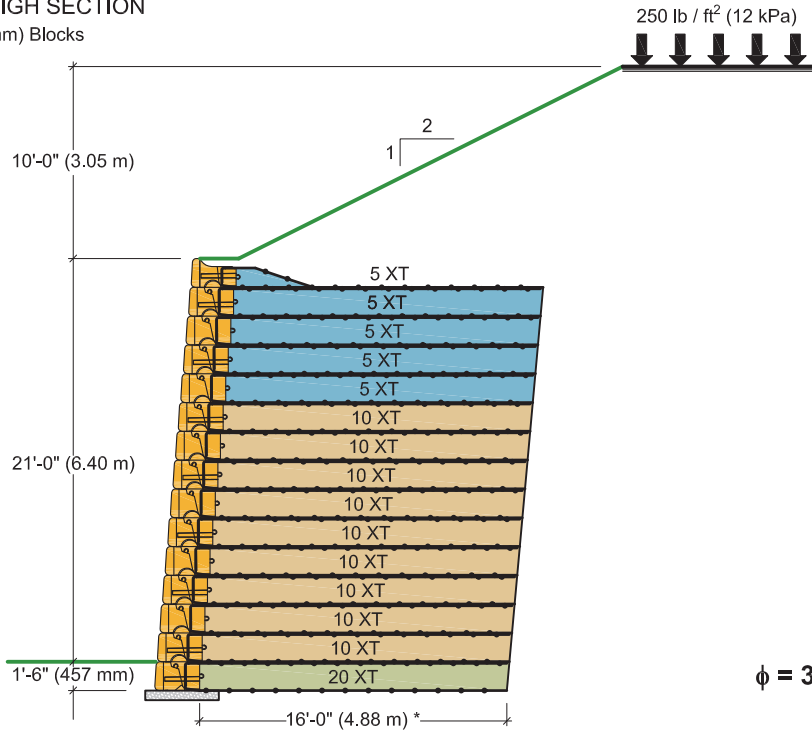

Geogrid Rolls Required per Wall Length		
Type	Rolls / linear ft	Rolls / linear m
5XT	± 0.26	± 0.85
10XT	± 0.47	± 1.54
20XT	± 0.05	± 0.17

$\phi = 34^\circ$

**Legend:**

= 28" (710mm) BLOCK

= 41" (1030 mm) BLOCK

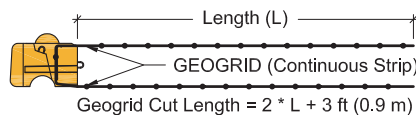

Geogrid shall be 12" (305 mm) wide strips of Mirafi geogrid, type as noted. Geogrid shall be **factory cut** and **certified** for width and strength by TenCate Mirafi.

**\* Geogrid length primarily controlled by global stability. Length will change with crest height.**

**SEE NOTES AND RECOMMENDED DETAILS AT START OF PRELIM. REINFORCEMENT SCHEDULE.**

# Preliminary Reinforcement Schedule

$\phi = 34^\circ$  | DENSE WELL-GRADED SAND or SAND AND GRAVEL

**LOAD CONDITION CR** | 1 : 2 CREST SLOPE, 10' (3.0 m) HIGH, 250 lb/ft<sup>2</sup> (12 kPa) SURCHARGE AT CREST, NO TOE SLOPE

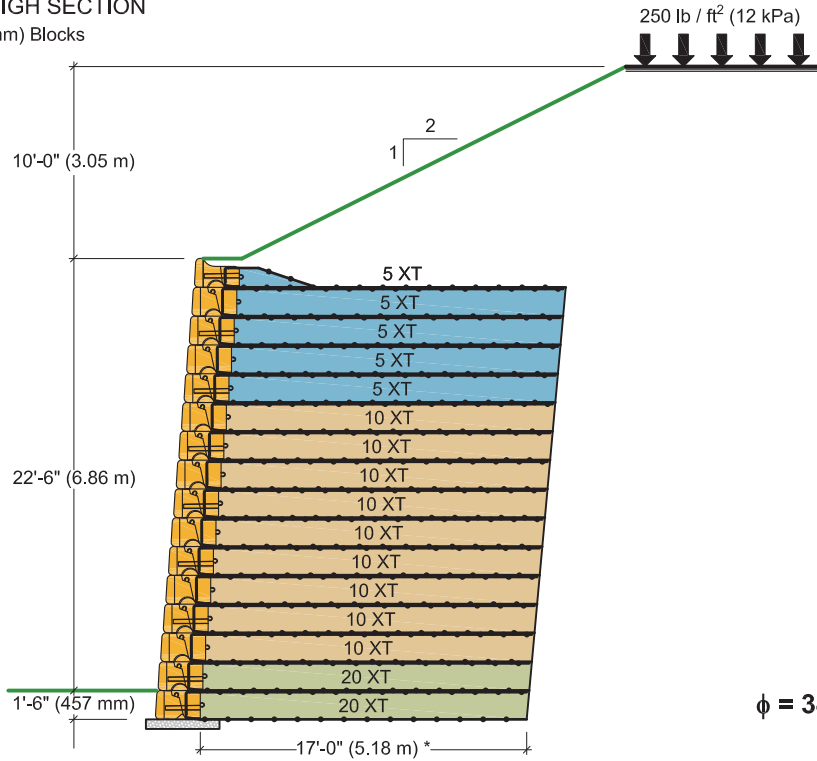

16 BLOCK HIGH SECTION  
(16) 28" (710 mm) Blocks



Geogrid Rolls Required per Wall Length		
Type	Rolls / linear ft	Rolls / linear m
5XT	± 0.26	± 0.85
10XT	± 0.47	± 1.54
20XT	± 0.10	± 0.34

$\phi = 34^\circ$

**Legend:**

-  = 28" (710mm) BLOCK
-  = 41" (1030 mm) BLOCK

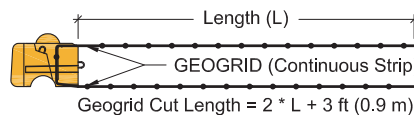

Geogrid shall be 12" (305 mm) wide strips of Mirafi geogrid, type as noted. Geogrid shall be **factory cut** and **certified** for width and strength by TenCate Mirafi.

**\* Geogrid length primarily controlled by global stability. Length will change with crest height.**

**SEE NOTES AND RECOMMENDED DETAILS AT START OF PRELIM. REINFORCEMENT SCHEDULE.**

# Preliminary Reinforcement Schedule

$\phi = 34^\circ$  | DENSE WELL-GRADED SAND or SAND AND GRAVEL

**LOAD CONDITION CR** | 1 : 2 CREST SLOPE, 10' (3.0 m) HIGH, 250 lb/ft<sup>2</sup> (12 kPa) SURCHARGE AT CREST, NO TOE SLOPE

17 BLOCK HIGH SECTION  
(17) 28" (710 mm) Blocks

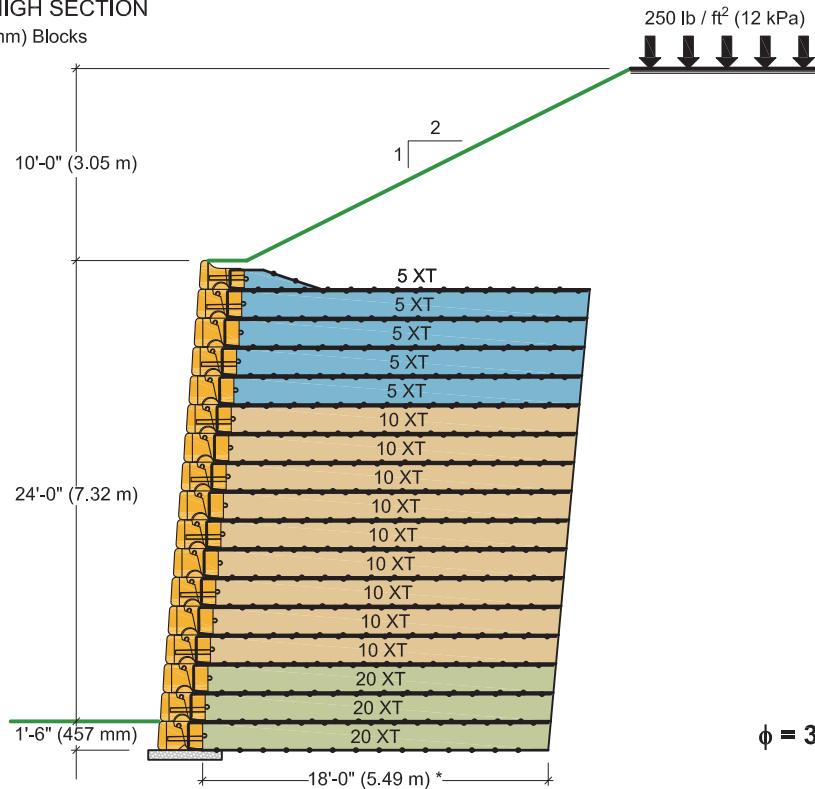

Geogrid Rolls Required per Wall Length		
Type	Rolls / linear ft	Rolls / linear m
5XT	± 0.26	± 0.85
10XT	± 0.47	± 1.54
20XT	± 0.16	± 0.51

$\phi = 34^\circ$

**Legend:**

- = 28" (710mm) BLOCK
- = 41" (1030 mm) BLOCK

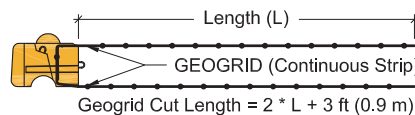

Geogrid shall be 12" (305 mm) wide strips of Mirafi geogrid, type as noted. Geogrid shall be **factory cut** and **certified** for width and strength by TenCate Mirafi.

**\* Geogrid length primarily controlled by global stability. Length will change with crest height.**

**SEE NOTES AND RECOMMENDED DETAILS AT START OF PRELIM. REINFORCEMENT SCHEDULE.**

# Preliminary Reinforcement Schedule

$\phi = 34^\circ$  | DENSE WELL-GRADED SAND or SAND AND GRAVEL

**LOAD CONDITION CR** | 1 : 2 CREST SLOPE, 10' (3.0 m) HIGH, 250 lb/ft<sup>2</sup> (12 kPa) SURCHARGE AT CREST, NO TOE SLOPE

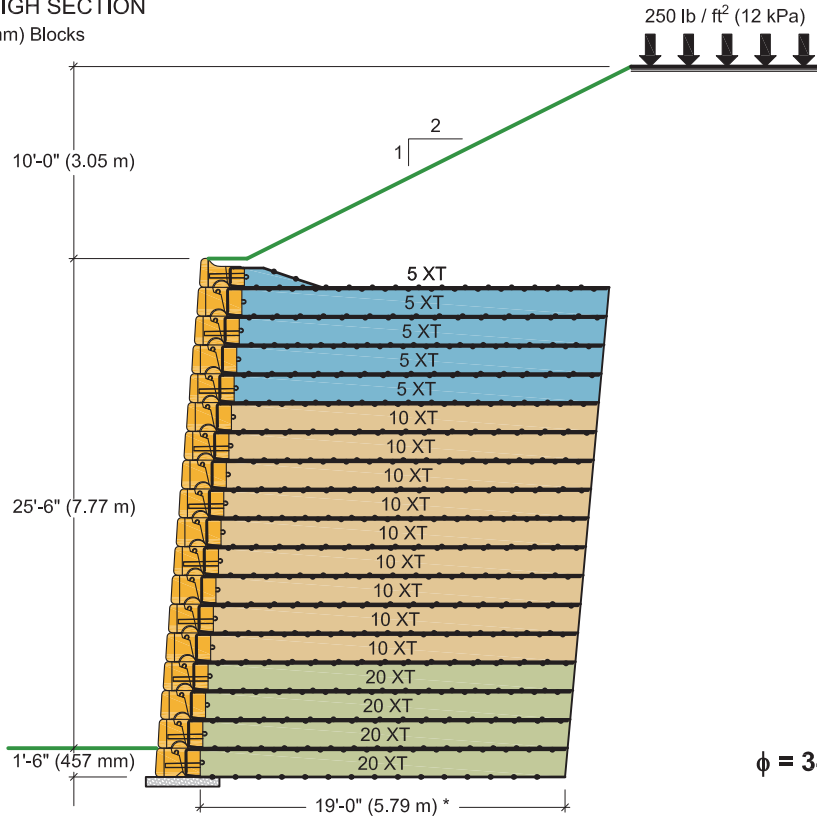

18 BLOCK HIGH SECTION  
(18) 28" (710 mm) Blocks



Geogrid Rolls Required per Wall Length		
Type	Rolls / linear ft	Rolls / linear m
5XT	± 0.33	± 1.07
10XT	± 0.59	± 1.92
20XT	± 0.26	± 0.85

$\phi = 34^\circ$

**Legend:**

-  = 28" (710mm) BLOCK
-  = 41" (1030 mm) BLOCK

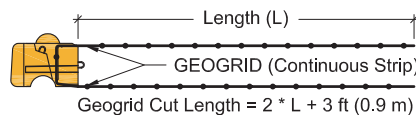

Geogrid shall be 12" (305 mm) wide strips of Mirafi geogrid, type as noted. Geogrid shall be **factory cut** and **certified** for width and strength by TenCate Mirafi.

**\* Geogrid length primarily controlled by global stability. Length will change with crest height.**

**SEE NOTES AND RECOMMENDED DETAILS AT START OF PRELIM. REINFORCEMENT SCHEDULE.**

# Preliminary Reinforcement Schedule

$\phi = 34^\circ$  | DENSE WELL-GRADED SAND or SAND AND GRAVEL

**LOAD CONDITION CR** | 1 : 2 CREST SLOPE, 10' (3.0 m) HIGH, 250 lb/ft<sup>2</sup> (12 kPa) SURCHARGE AT CREST, NO TOE SLOPE

19 BLOCK HIGH SECTION  
(19) 28" (710 mm) Blocks

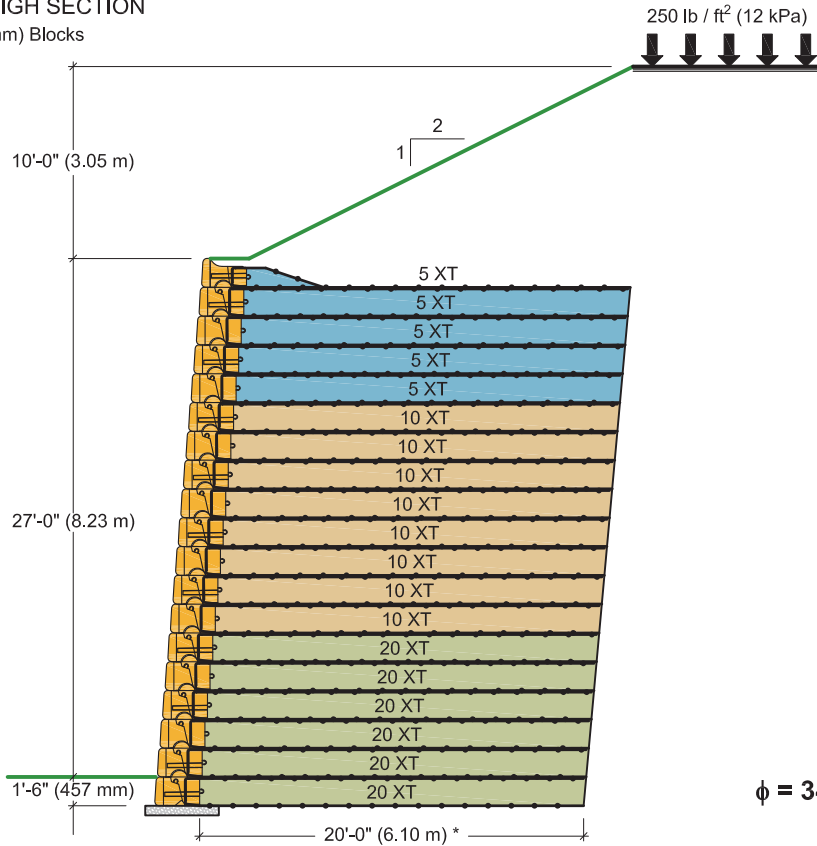

Geogrid Rolls Required per Wall Length		
Type	Rolls / linear ft	Rolls / linear m
5XT	± 0.33	± 1.07
10XT	± 0.52	± 1.71
20XT	± 0.39	± 1.28

$\phi = 34^\circ$

**Legend:**

= 28" (710mm) BLOCK

= 41" (1030 mm) BLOCK

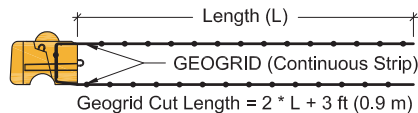

Geogrid shall be 12" (305 mm) wide strips of Mirafi geogrid, type as noted. Geogrid shall be **factory cut** and **certified** for width and strength by TenCate Mirafi.

**\* Geogrid length primarily controlled by global stability. Length will change with crest height.**

**SEE NOTES AND RECOMMENDED DETAILS AT START OF PRELIM. REINFORCEMENT SCHEDULE.**

# Preliminary Reinforcement Schedule

$\phi = 34^\circ$  | DENSE WELL-GRADED SAND or SAND AND GRAVEL

**LOAD CONDITION CR** | 1 : 2 CREST SLOPE, 10' (3.0 m) HIGH, 250 lb/ft<sup>2</sup> (12 kPa) SURCHARGE AT CREST, NO TOE SLOPE

20 BLOCK HIGH SECTION \*\*  
(20) 28" (710 mm) Blocks

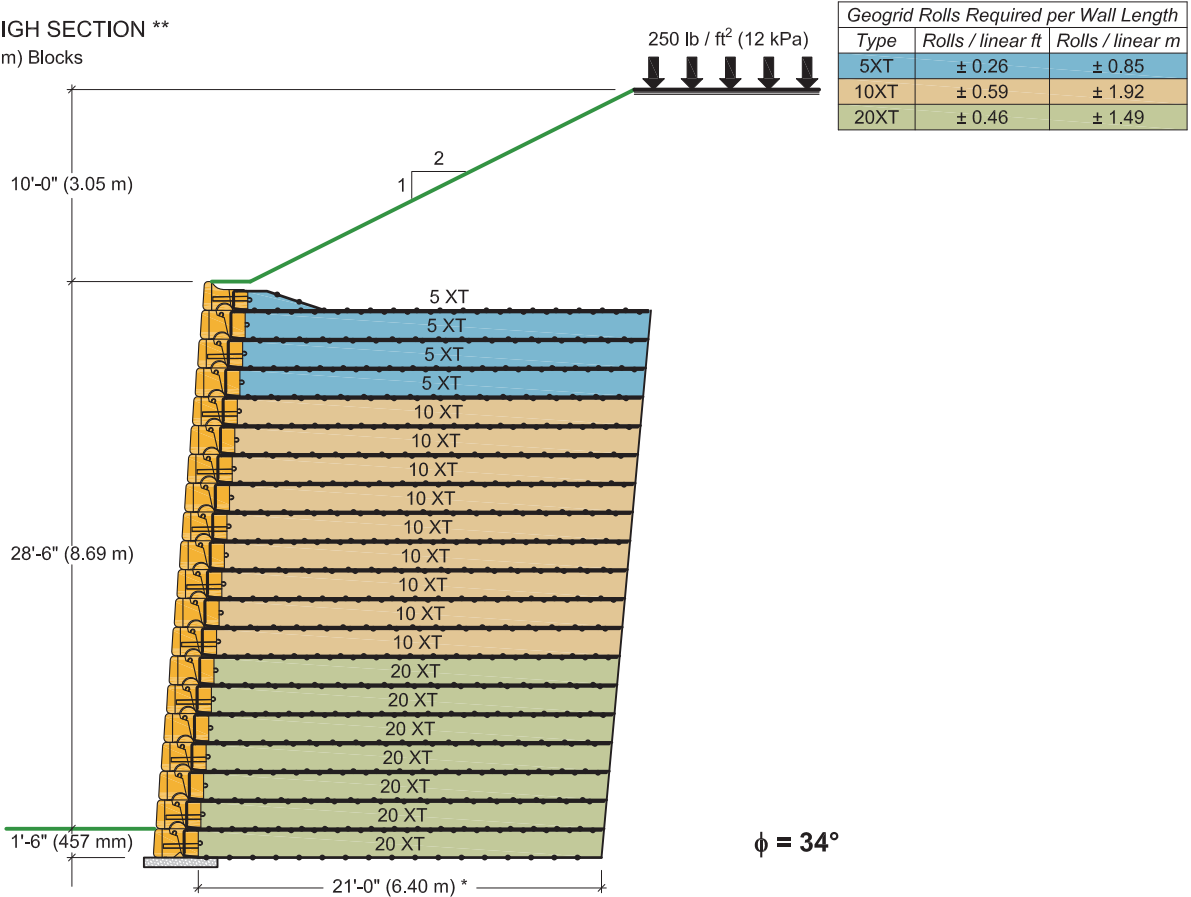

**Legend:**

= 28" (710mm) BLOCK

= 41" (1030 mm) BLOCK

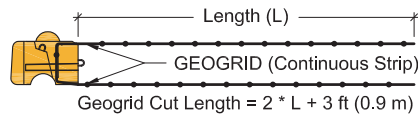

Geogrid shall be 12" (305 mm) wide strips of Mirafi geogrid, type as noted. Geogrid shall be **factory cut** and **certified** for width and strength by TenCate Mirafi.

\* **Geogrid length primarily controlled by global stability. Length will change with crest height.**

\*\* **Not tall enough? You can build significantly taller walls with the Redi-Rock PC System...we just had to stop the preliminary sections somewhere. Talk to your Engineer or give us a call for more info.**

**SEE NOTES AND RECOMMENDED DETAILS AT START OF PRELIM. REINFORCEMENT SCHEDULE.**

# Preliminary Reinforcement Schedule

$\phi = 30^\circ$  | FINE TO MEDIUM SAND or SILTY SAND

Positive Connection System MSE Walls	SECTION 2 OF 3
Assumed reinforced zone, retained, and foundation soils for this Section	SW, SP, SM
Internal angle of friction	$\phi = 30^\circ$
Unit weight	$\gamma = 120 \text{ lb / ft}^3 \text{ (18.8 kN / m}^3\text{)}$
Cohesion	$c = 0 \text{ lb / ft}^2 \text{ (0 kPa)}$

**LOAD CONDITION A** | NO LIVE LOAD SURFACE, NO BACK SLOPE, NO TOE SLOPE.....159

**LOAD CONDITION B** | 250 lb/ft<sup>2</sup> (12 kPa) LIVE LOAD SURCHARGE, NO BACK SLOPE, NO TOE SLOPE.....166

**LOAD CONDITION CR** | 1 : 2 CREST SLOPE, 10' (3.0 m) HIGH, 250 lb/ft<sup>2</sup> (12 kPa) LIVE LOAD SURCHARGE AT CREST, NO TOE SLOPE .....175

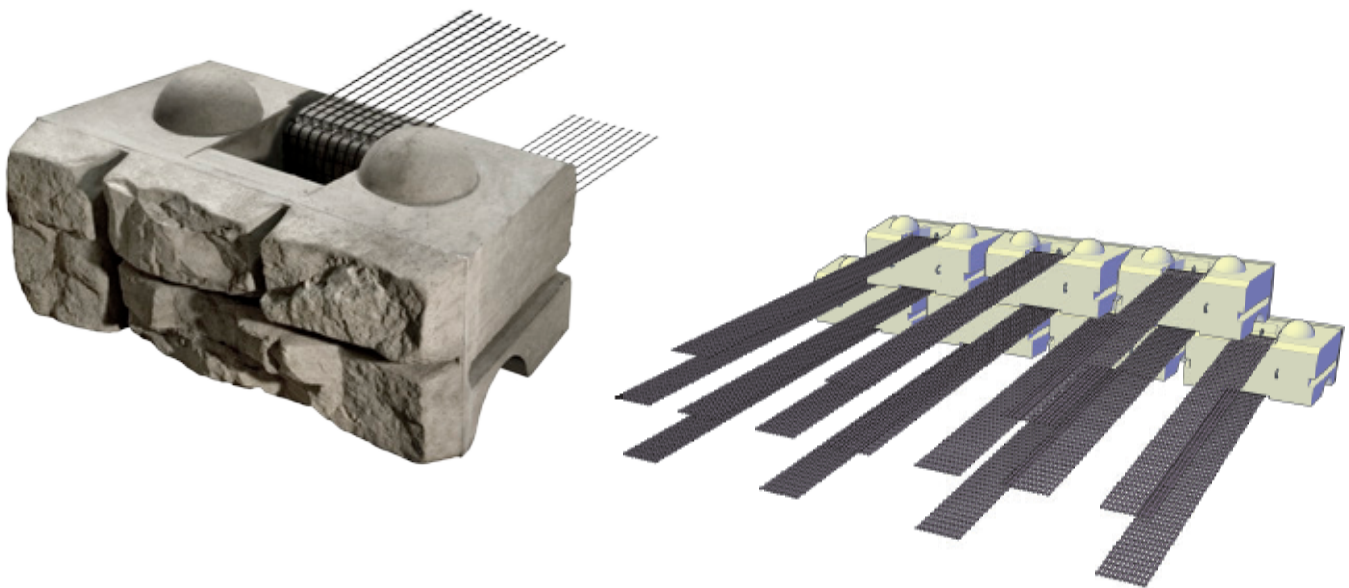

# Preliminary Reinforcement Schedule

$\phi = 30^\circ$  | FINE TO MEDIUM SAND or SILTY SAND

**LOAD CONDITION A** | NO LIVE LOAD SURCHARGE, NO BACK SLOPE, NO TOE SLOPE

2 BLOCK SECTION  
(2) 28" (710 mm) Blocks

Geogrid Rolls Required per Wall Length		
Type	Rolls / linear ft	Rolls / linear m
No Geogrid Needed		

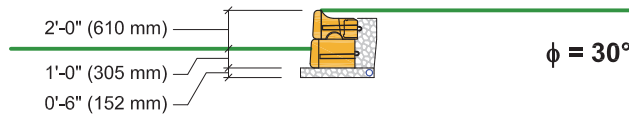

3 BLOCK SECTION  
(3) 28" (710 mm) Blocks

Geogrid Rolls Required per Wall Length		
Type	Rolls / linear ft	Rolls / linear m
No Geogrid Needed		

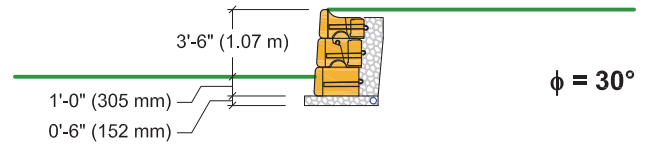

4 BLOCK SECTION  
(3) 28" (710 mm) Blocks  
(1) 41" (1030 mm) Block

Geogrid Rolls Required per Wall Length		
Type	Rolls / linear ft	Rolls / linear m
No Geogrid Needed		

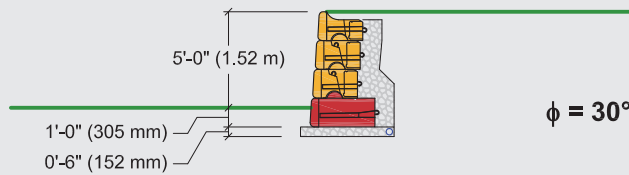

5 BLOCK SECTION  
(5) 28" (710 mm) Blocks

Geogrid Rolls Required per Wall Length		
Type	Rolls / linear ft	Rolls / linear m
5XT	± 0.13	± 0.43

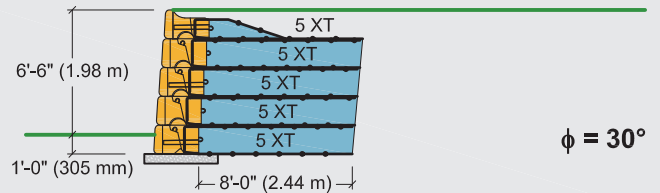

6 BLOCK SECTION  
(6) 28" (710 mm) Blocks

Geogrid Rolls Required per Wall Length		
Type	Rolls / linear ft	Rolls / linear m
5XT	± 0.16	± 0.51

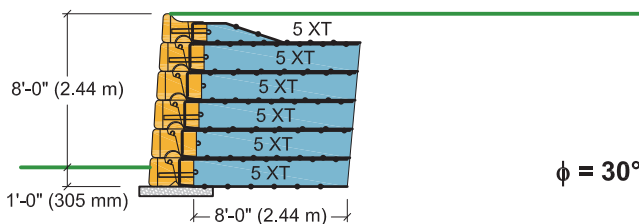

7 BLOCK SECTION  
(7) 28" (710 mm) Blocks

Geogrid Rolls Required per Wall Length		
Type	Rolls / linear ft	Rolls / linear m
5XT	± 0.18	± 0.60

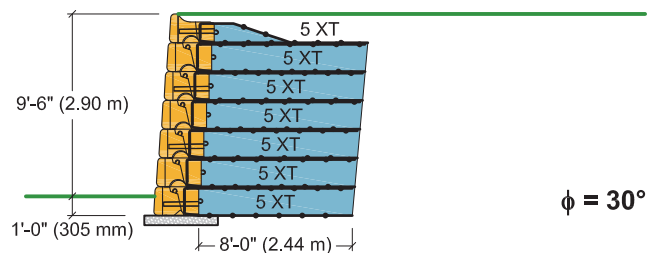

**Legend:**

- = 28" (710mm) BLOCK
- = 41" (1030 mm) BLOCK

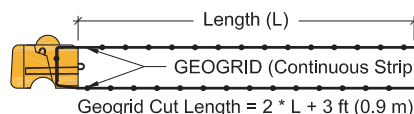

Geogrid shall be 12" (305 mm) wide strips of Mirafi geogrid, type as noted. Geogrid shall be **factory cut** and **certified** for width and strength by TenCate Mirafi.

**SEE NOTES AND RECOMMENDED DETAILS AT START OF PRELIM. REINFORCEMENT SCHEDULE.**

# Preliminary Reinforcement Schedule

$\phi = 30^\circ$  | FINE TO MEDIUM SAND or SILTY SAND

**LOAD CONDITION A** | NO LIVE LOAD SURCHARGE, NO BACK SLOPE, NO TOE SLOPE

8 BLOCK SECTION  
(8) 28" (710 mm) Blocks

Geogrid Rolls Required per Wall Length		
Type	Rolls / linear ft	Rolls / linear m
5XT	± 0.20	± 0.66
8XT	± 0.03	± 0.09

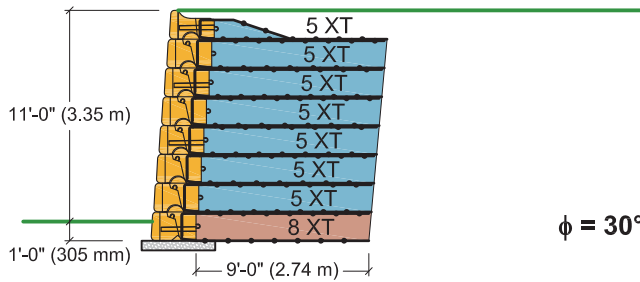

9 BLOCK SECTION  
(9) 28" (710 mm) Blocks

Geogrid Rolls Required per Wall Length		
Type	Rolls / linear ft	Rolls / linear m
5XT	± 0.23	± 0.75
8XT	± 0.07	± 0.21

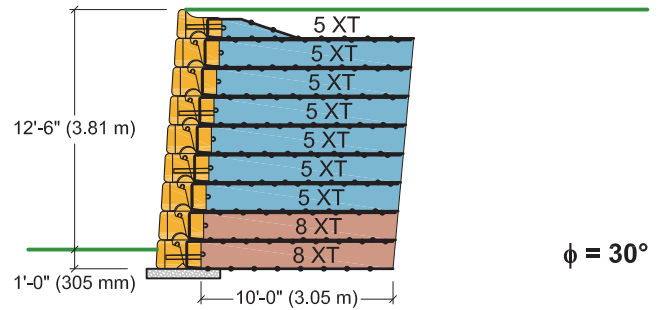

10 BLOCK SECTION  
(10) 28" (710 mm) Blocks

Geogrid Rolls Required per Wall Length		
Type	Rolls / linear ft	Rolls / linear m
5XT	± 0.23	± 0.75
8XT	± 0.10	± 0.32

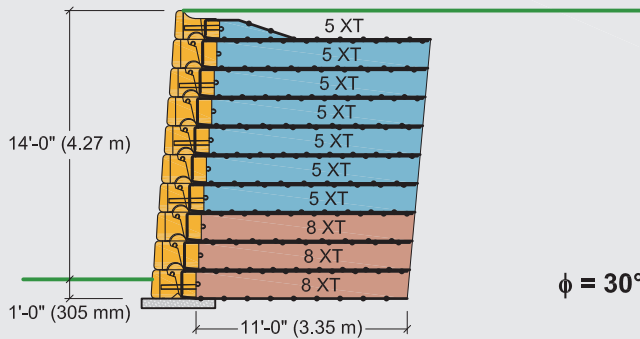

11 BLOCK SECTION  
(11) 28" (710 mm) Blocks

Geogrid Rolls Required per Wall Length		
Type	Rolls / linear ft	Rolls / linear m
5XT	± 0.26	± 0.85
8XT	± 0.15	± 0.49

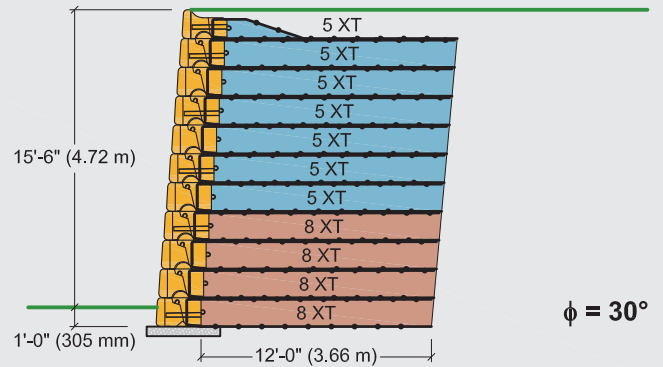

**Legend:**

= 28" (710mm) BLOCK

= 41" (1030 mm) BLOCK

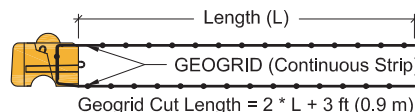

Geogrid shall be 12" (305 mm) wide strips of Mirafi geogrid, type as noted. Geogrid shall be **factory cut** and **certified** for width and strength by TenCate Mirafi.

**SEE NOTES AND RECOMMENDED DETAILS AT START OF PRELIM. REINFORCEMENT SCHEDULE.**

# Preliminary Reinforcement Schedule

$\phi = 30^\circ$  | FINE TO MEDIUM SAND or SILTY SAND

**LOAD CONDITION A** | NO LIVE LOAD SURCHARGE, NO BACK SLOPE, NO TOE SLOPE

12 BLOCK SECTION  
(12) 28" (710 mm) Blocks

Geogrid Rolls Required per Wall Length		
Type	Rolls / linear ft	Rolls / linear m
5XT	± 0.30	± 1.00
8XT	± 0.22	± 0.71

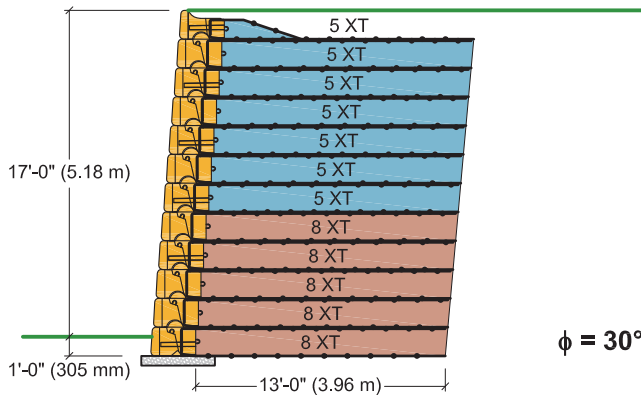

13 BLOCK SECTION  
(13) 28" (710 mm) Blocks

Geogrid Rolls Required per Wall Length		
Type	Rolls / linear ft	Rolls / linear m
5XT	± 0.30	± 1.00
10XT	± 0.26	± 0.85

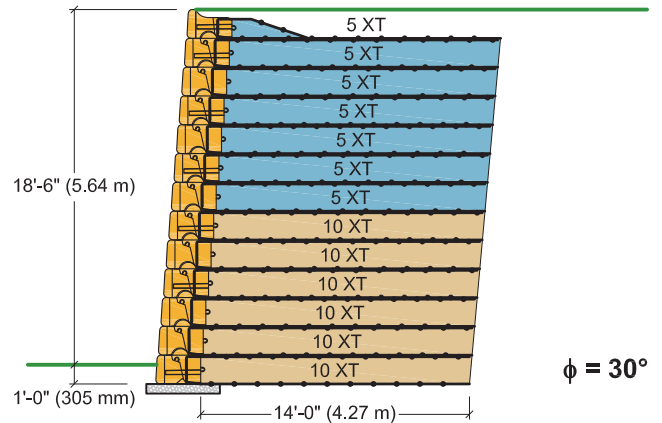

14 BLOCK SECTION  
(14) 28" (710 mm) Blocks

Geogrid Rolls Required per Wall Length		
Type	Rolls / linear ft	Rolls / linear m
5XT	± 0.26	± 0.85
10XT	± 0.30	± 1.00

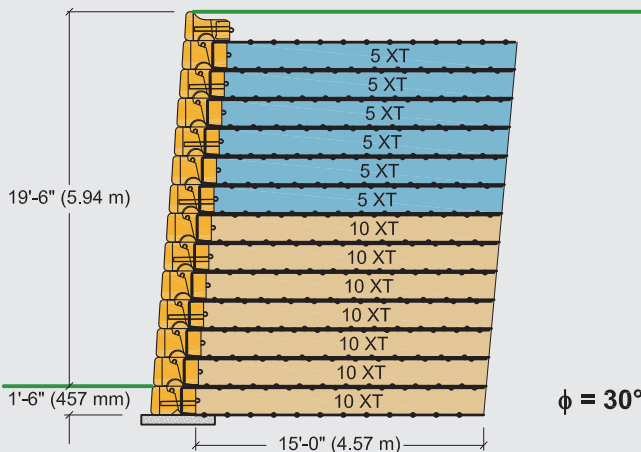

15 BLOCK SECTION  
(15) 28" (710 mm) Blocks

Geogrid Rolls Required per Wall Length		
Type	Rolls / linear ft	Rolls / linear m
5XT	± 0.31	± 1.02
10XT	± 0.42	± 1.37

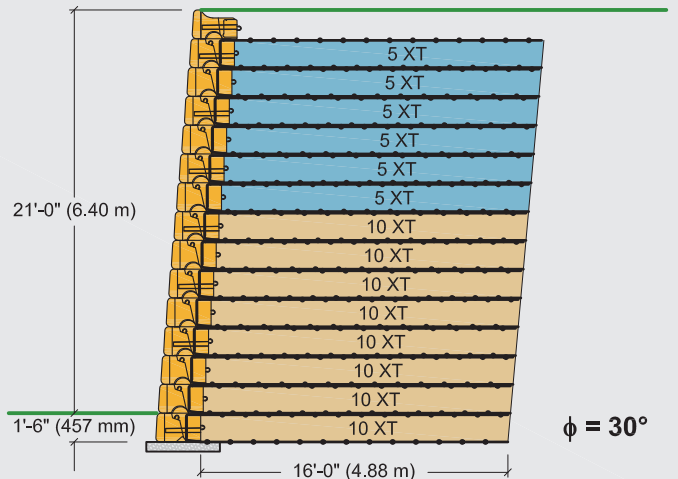

**Legend:**

= 28" (710mm) BLOCK

= 41" (1030 mm) BLOCK

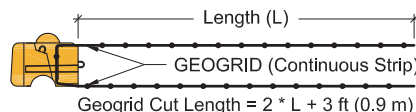

Geogrid shall be 12" (305 mm) wide strips of Mirafi geogrid, type as noted. Geogrid shall be **factory cut** and **certified** for width and strength by TenCate Mirafi.

**SEE NOTES AND RECOMMENDED DETAILS AT START OF PRELIM. REINFORCEMENT SCHEDULE.**

# Preliminary Reinforcement Schedule

$\phi = 30^\circ$  | FINE TO MEDIUM SAND or SILTY SAND

**LOAD CONDITION A** | NO LIVE LOAD SURCHARGE, NO BACK SLOPE, NO TOE SLOPE

16 BLOCK SECTION  
(16) 28" (710 mm) Blocks

Geogrid Rolls Required per Wall Length		
Type	Rolls / linear ft	Rolls / linear m
5XT	± 0.31	± 1.02
10XT	± 0.47	± 1.54

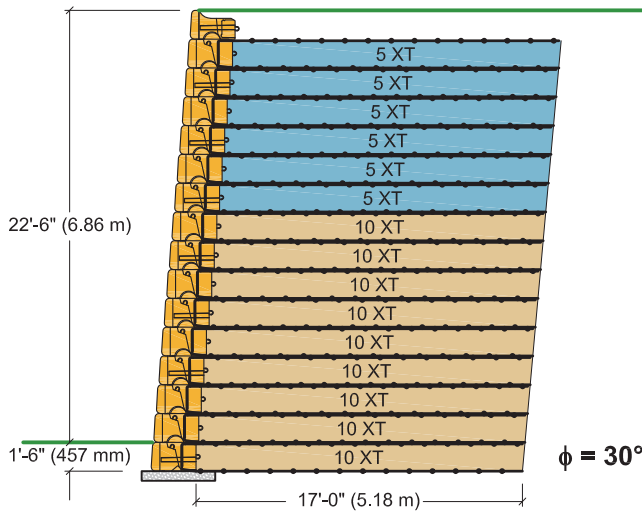

17 BLOCK SECTION  
(17) 28" (710 mm) Blocks

Geogrid Rolls Required per Wall Length		
Type	Rolls / linear ft	Rolls / linear m
5XT	± 0.31	± 1.02
10XT	± 0.42	± 1.37
20XT	± 0.10	± 0.34

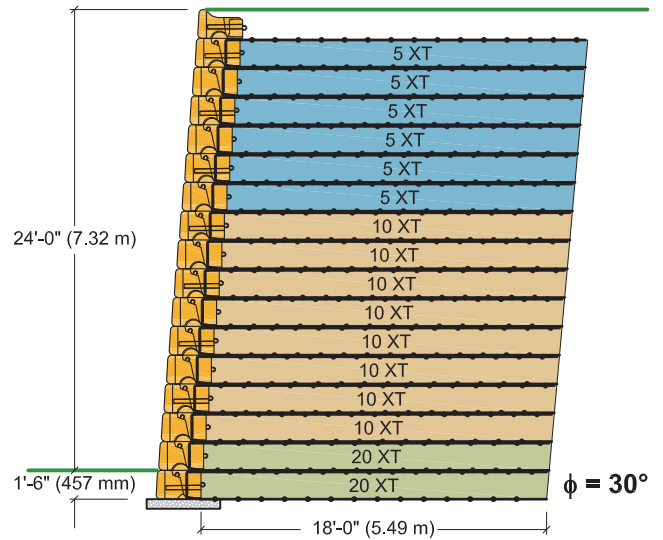

**Legend:**

= 28" (710mm) BLOCK

= 41" (1030 mm) BLOCK

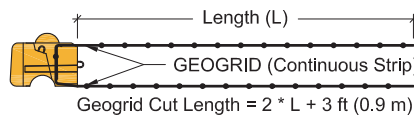

Geogrid shall be 12" (305 mm) wide strips of Mirafi geogrid, type as noted. Geogrid shall be **factory cut** and **certified** for width and strength by TenCate Mirafi.

**SEE NOTES AND RECOMMENDED DETAILS AT START OF PRELIM. REINFORCEMENT SCHEDULE.**

# Preliminary Reinforcement Schedule

$\phi = 30^\circ$  | FINE TO MEDIUM SAND or SILTY SAND



**LOAD CONDITION A** | NO LIVE LOAD SURCHARGE, NO BACK SLOPE, NO TOE SLOPE

18 BLOCK SECTION  
(18) 28" (710 mm) Blocks

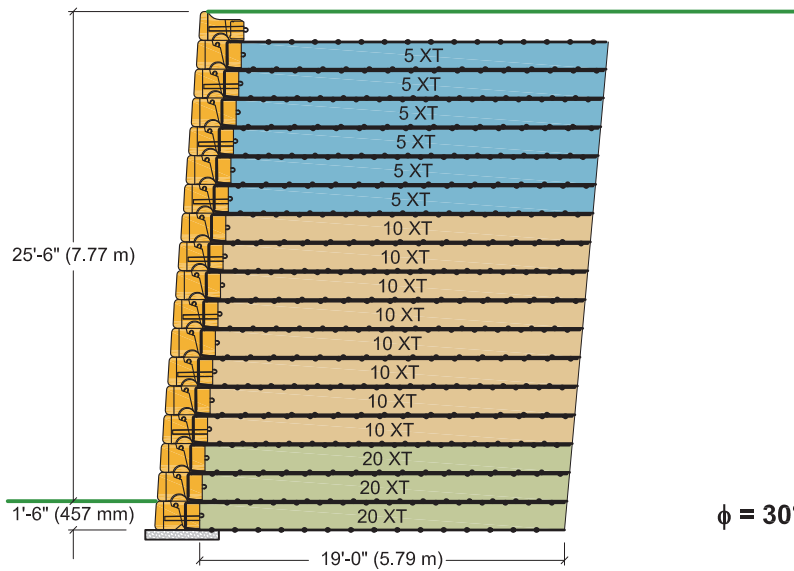
Geogrid Rolls Required per Wall Length		
Type	Rolls / linear ft	Rolls / linear m
5XT	± 0.39	± 1.28
10XT	± 0.52	± 1.71
20XT	± 0.20	± 0.64



**Legend:**

-  = 28" (710mm) BLOCK
-  = 41" (1030 mm) BLOCK

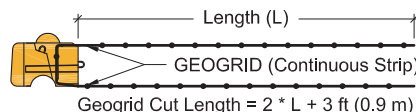

Geogrid shall be 12" (305 mm) wide strips of Mirafi geogrid, type as noted. Geogrid shall be **factory cut** and **certified** for width and strength by TenCate Mirafi.

**SEE NOTES AND RECOMMENDED DETAILS AT START OF PRELIM. REINFORCEMENT SCHEDULE.**

# Preliminary Reinforcement Schedule

$\phi = 30^\circ$  | FINE TO MEDIUM SAND or SILTY SAND



**LOAD CONDITION A** | NO LIVE LOAD SURCHARGE, NO BACK SLOPE, NO TOE SLOPE

19 BLOCK SECTION  
(19) 28" (710 mm) Blocks

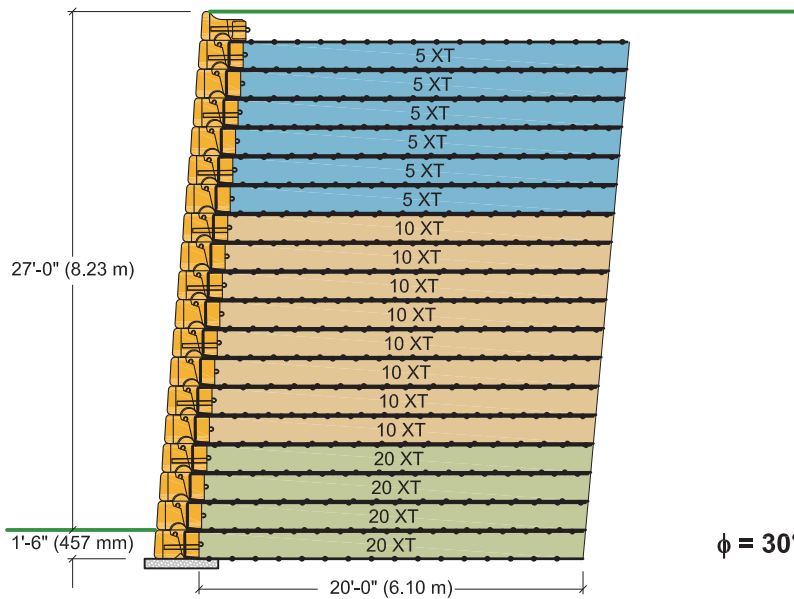
Geogrid Rolls Required per Wall Length		
Type	Rolls / linear ft	Rolls / linear m
5XT	± 0.39	± 1.28
10XT	± 0.52	± 1.71
20XT	± 0.26	± 0.85



**Legend:**

-  = 28" (710mm) BLOCK
-  = 41" (1030 mm) BLOCK

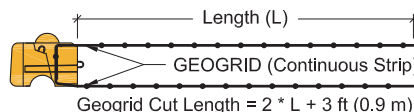

Geogrid shall be 12" (305 mm) wide strips of Mirafi geogrid, type as noted. Geogrid shall be **factory cut** and **certified** for width and strength by TenCate Mirafi.

**SEE NOTES AND RECOMMENDED DETAILS AT START OF PRELIM. REINFORCEMENT SCHEDULE.**

# Preliminary Reinforcement Schedule

$\phi = 30^\circ$  | FINE TO MEDIUM SAND or SILTY SAND



**LOAD CONDITION A** | NO LIVE LOAD SURCHARGE, NO BACK SLOPE, NO TOE SLOPE

20 BLOCK SECTION \*  
(20) 28" (710 mm) Blocks

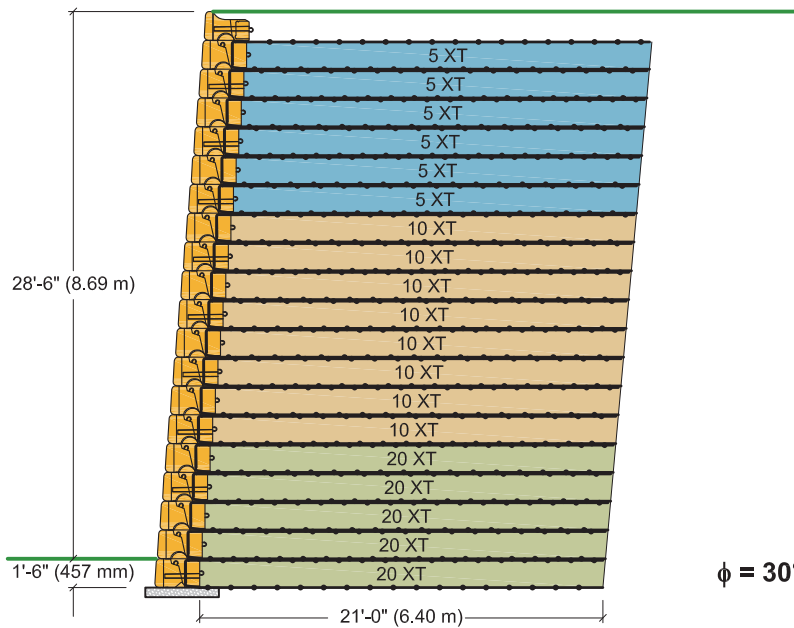
Geogrid Rolls Required per Wall Length		
Type	Rolls / linear ft	Rolls / linear m
5XT	± 0.39	± 1.28
10XT	± 0.52	± 1.71
20XT	± 0.33	± 1.07



**Legend:**

-  = 28" (710mm) BLOCK
-  = 41" (1030 mm) BLOCK

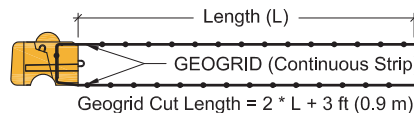

Geogrid shall be 12" (305 mm) wide strips of Mirafi geogrid, type as noted. Geogrid shall be **factory cut** and **certified** for width and strength by TenCate Mirafi.

**\* Not tall enough? You can build significantly taller walls with the Redi-Rock PC System...we just had to stop the preliminary sections somewhere. Talk to your Engineer or give us a call for more info.**

**SEE NOTES AND RECOMMENDED DETAILS AT START OF PRELIM. REINFORCEMENT SCHEDULE.**

# Preliminary Reinforcement Schedule

$\phi = 30^\circ$  | FINE TO MEDIUM SAND or SILTY SAND

**LOAD CONDITION B** | 250 lb/ft<sup>2</sup> (12 kPa) LIVE LOAD SURCHARGE, NO BACK SLOPE, NO TOE SLOPE

**2 BLOCK SECTION**  
 (1) 28" (710 mm) Block  
 (1) 41" (1030 mm) Block

Geogrid Rolls Required per Wall Length		
Type	Rolls / linear ft	Rolls / linear m
No Geogrid Needed		

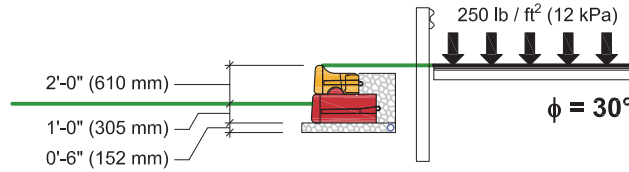

**3 BLOCK SECTION**  
 (3) 28" (710 mm) Blocks

Geogrid Rolls Required per Wall Length		
Type	Rolls / linear ft	Rolls / linear m
5XT	± 0.10	± 0.32

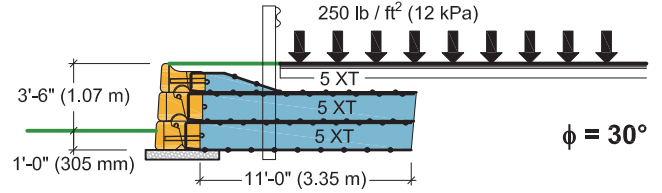

**4 BLOCK SECTION**  
 (4) 28" (710 mm) Blocks

Geogrid Rolls Required per Wall Length		
Type	Rolls / linear ft	Rolls / linear m
5XT	± 0.15	± 0.49

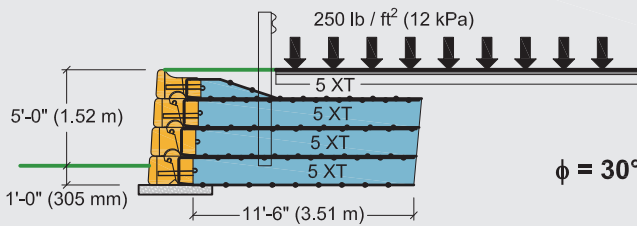

**5 BLOCK SECTION**  
 (5) 28" (710 mm) Blocks

Geogrid Rolls Required per Wall Length		
Type	Rolls / linear ft	Rolls / linear m
5XT	± 0.19	± 0.61

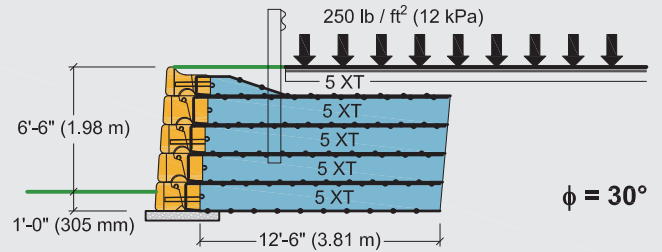

**6 BLOCK SECTION**  
 (6) 28" (710 mm) Blocks

Geogrid Rolls Required per Wall Length		
Type	Rolls / linear ft	Rolls / linear m
5XT	± 0.26	± 0.85

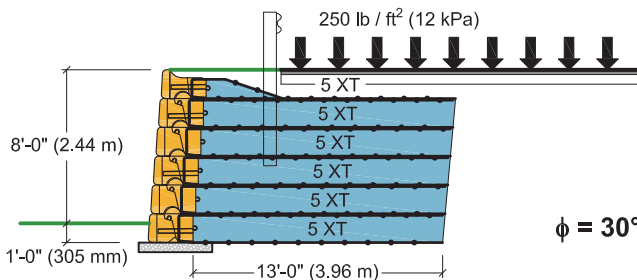

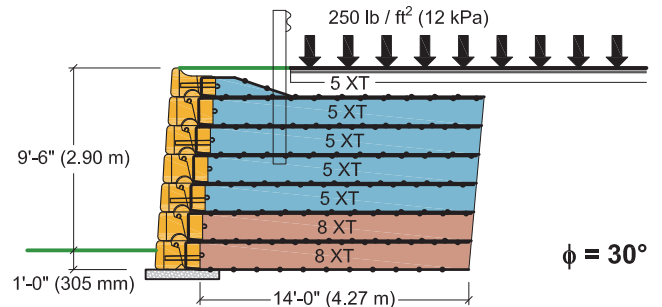

**7 BLOCK SECTION**  
 (7) 28" (710 mm) Blocks

Geogrid Rolls Required per Wall Length		
Type	Rolls / linear ft	Rolls / linear m
5XT	± 0.22	± 0.71
8XT	± 0.09	± 0.28



**Legend:**

-  = 28" (710mm) BLOCK
-  = 41" (1030 mm) BLOCK

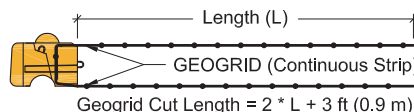

Geogrid shall be 12" (305 mm) wide strips of Mirafi geogrid, type as noted. Geogrid shall be **factory cut** and **certified** for width and strength by TenCate Mirafi.

**SEE NOTES AND RECOMMENDED DETAILS AT START OF PRELIM. REINFORCEMENT SCHEDULE.**

# Preliminary Reinforcement Schedule

$\phi = 30^\circ$  | FINE TO MEDIUM SAND or SILTY SAND

**LOAD CONDITION B** | 250 lb/ft<sup>2</sup> (12 kPa) LIVE LOAD SURCHARGE, NO BACK SLOPE, NO TOE SLOPE

8 BLOCK SECTION  
(8) 28" (710 mm) Blocks

Geogrid Rolls Required per Wall Length		
Type	Rolls / linear ft	Rolls / linear m
5XT	± 0.22	± 0.71
8XT	± 0.13	± 0.43

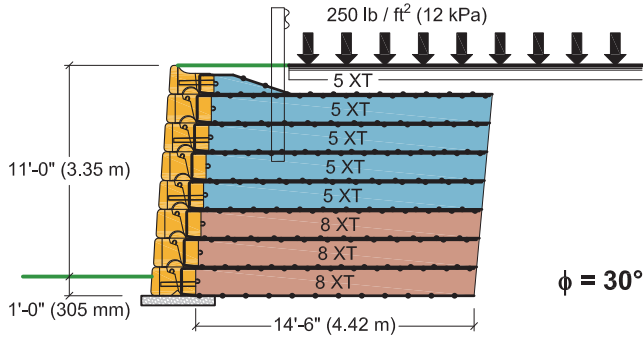

9 BLOCK SECTION  
(9) 28" (710 mm) Blocks

Geogrid Rolls Required per Wall Length		
Type	Rolls / linear ft	Rolls / linear m
5XT	± 0.26	± 0.85
8XT	± 0.21	± 0.68

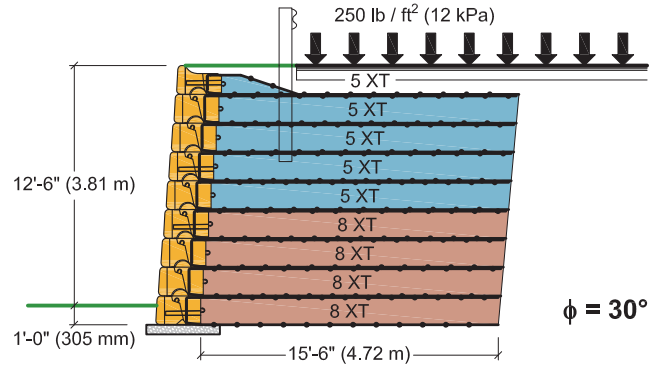

10 BLOCK SECTION  
(10) 28" (710 mm) Blocks

Geogrid Rolls Required per Wall Length		
Type	Rolls / linear ft	Rolls / linear m
5XT	± 0.26	± 0.85
8XT	± 0.26	± 0.85

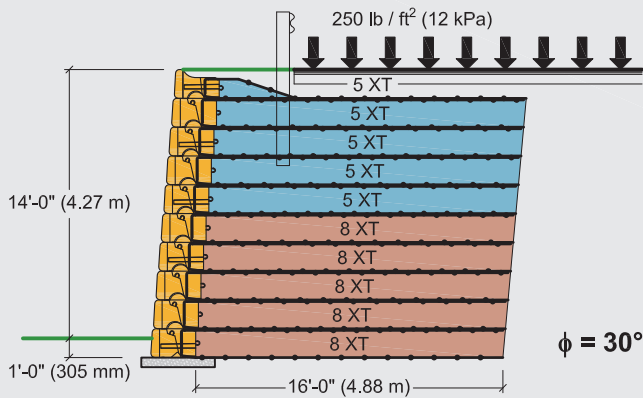

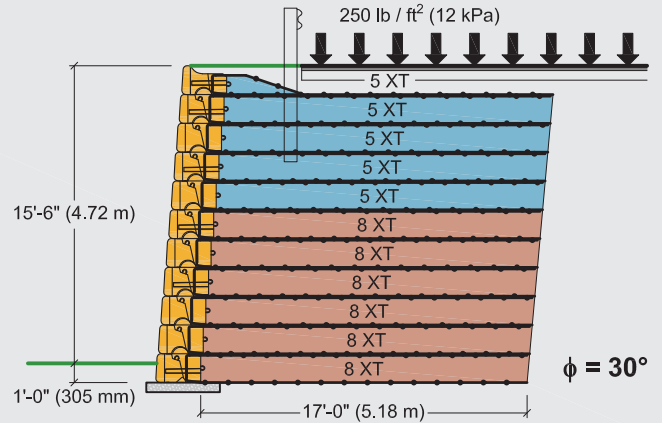

11 BLOCK SECTION  
(11) 28" (710 mm) Blocks

Geogrid Rolls Required per Wall Length		
Type	Rolls / linear ft	Rolls / linear m
5XT	± 0.26	± 0.85
8XT	± 0.31	± 1.02



**Legend:**

-  = 28" (710mm) BLOCK
-  = 41" (1030 mm) BLOCK

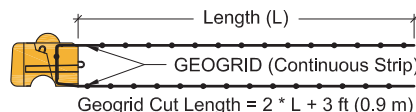

Geogrid shall be 12" (305 mm) wide strips of Mirafi geogrid, type as noted. Geogrid shall be **factory cut** and **certified** for width and strength by TenCate Mirafi.

**SEE NOTES AND RECOMMENDED DETAILS AT START OF PRELIM. REINFORCEMENT SCHEDULE.**

# Preliminary Reinforcement Schedule

$\phi = 30^\circ$  | FINE TO MEDIUM SAND or SILTY SAND

**LOAD CONDITION B** | 250 lb/ft<sup>2</sup> (12 kPa) LIVE LOAD SURCHARGE, NO BACK SLOPE, NO TOE SLOPE

12 BLOCK SECTION  
(12) 28" (710 mm) Blocks

Geogrid Rolls Required per Wall Length		
Type	Rolls / linear ft	Rolls / linear m
5XT	± 0.26	± 0.85
10XT	± 0.36	± 1.19

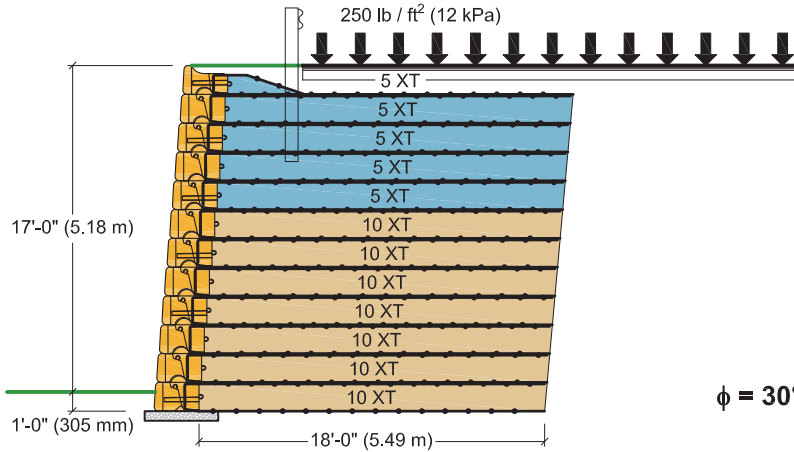

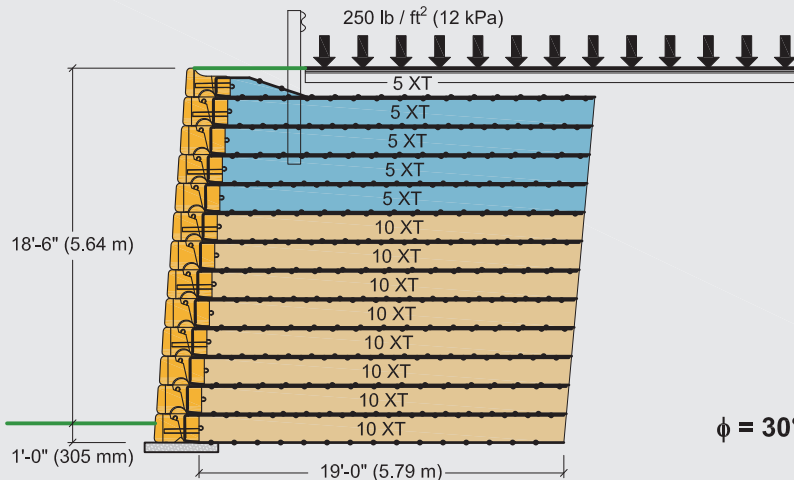

13 BLOCK SECTION  
(13) 28" (710 mm) Blocks

Geogrid Rolls Required per Wall Length		
Type	Rolls / linear ft	Rolls / linear m
5XT	± 0.33	± 1.07
10XT	± 0.52	± 1.71



**Legend:**

-  = 28" (710mm) BLOCK
-  = 41" (1030 mm) BLOCK

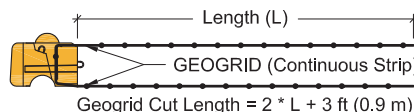

Geogrid shall be 12" (305 mm) wide strips of Mirafi geogrid, type as noted. Geogrid shall be **factory cut** and **certified** for width and strength by TenCate Mirafi.

**SEE NOTES AND RECOMMENDED DETAILS AT START OF PRELIM. REINFORCEMENT SCHEDULE.**

# Preliminary Reinforcement Schedule

$\phi = 30^\circ$  | FINE TO MEDIUM SAND or SILTY SAND

**LOAD CONDITION B** | 250 lb/ft<sup>2</sup> (12 kPa) LIVE LOAD SURCHARGE, NO BACK SLOPE, NO TOE SLOPE

14 BLOCK SECTION  
(14) 28" (710 mm) Blocks

Geogrid Rolls Required per Wall Length		
Type	Rolls / linear ft	Rolls / linear m
5XT	± 0.33	± 1.07
10XT	± 0.59	± 1.92

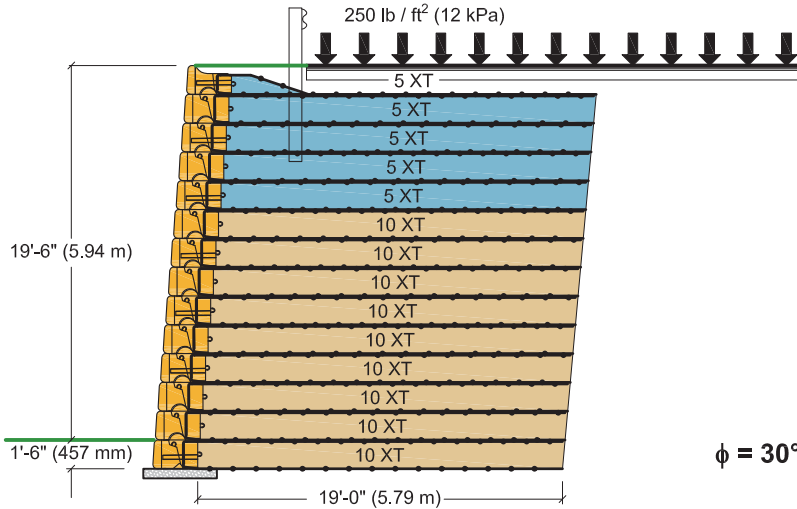

15 BLOCK SECTION  
(15) 28" (710 mm) Blocks

Geogrid Rolls Required per Wall Length		
Type	Rolls / linear ft	Rolls / linear m
5XT	± 0.33	± 1.07
10XT	± 0.59	± 1.92
20XT	± 0.07	± 0.21

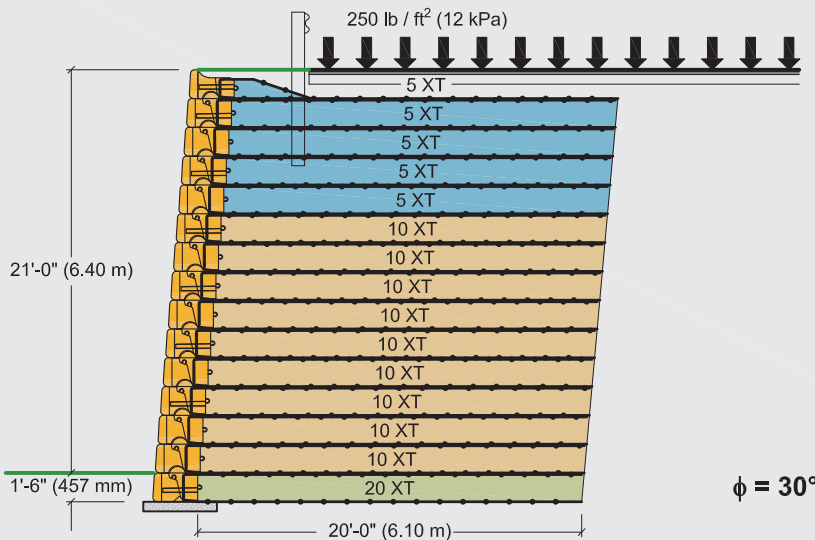

**Legend:**

= 28" (710mm) BLOCK

= 41" (1030 mm) BLOCK

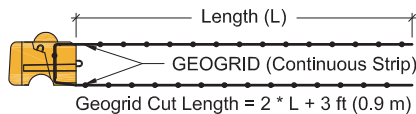

Geogrid shall be 12" (305 mm) wide strips of Mirafi geogrid, type as noted. Geogrid shall be **factory cut** and **certified** for width and strength by TenCate Mirafi.

**SEE NOTES AND RECOMMENDED DETAILS AT START OF PRELIM. REINFORCEMENT SCHEDULE.**

# Preliminary Reinforcement Schedule

$\phi = 30^\circ$  | FINE TO MEDIUM SAND or SILTY SAND



**LOAD CONDITION B** | 250 lb/ft<sup>2</sup> (12 kPa) LIVE LOAD SURCHARGE, NO BACK SLOPE, NO TOE SLOPE

16 BLOCK SECTION  
(16) 28" (710 mm) Blocks

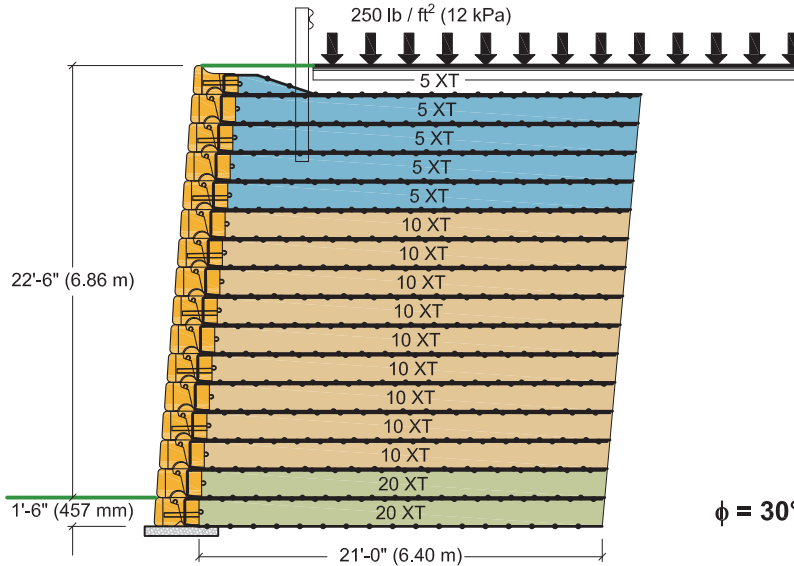
Geogrid Rolls Required per Wall Length		
Type	Rolls / linear ft	Rolls / linear m
5XT	± 0.33	± 1.07
10XT	± 0.59	± 1.92
20XT	± 0.13	± 0.43



**Legend:**

-  = 28" (710mm) BLOCK
-  = 41" (1030 mm) BLOCK

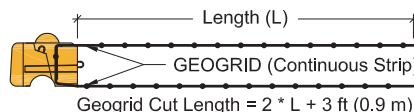

Geogrid shall be 12" (305 mm) wide strips of Mirafi geogrid, type as noted. Geogrid shall be **factory cut** and **certified** for width and strength by TenCate Mirafi.

**SEE NOTES AND RECOMMENDED DETAILS AT START OF PRELIM. REINFORCEMENT SCHEDULE.**

# Preliminary Reinforcement Schedule

$\phi = 30^\circ$  | FINE TO MEDIUM SAND or SILTY SAND



**LOAD CONDITION B** | 250 lb/ft<sup>2</sup> (12 kPa) LIVE LOAD SURCHARGE, NO BACK SLOPE, NO TOE SLOPE

17 BLOCK SECTION  
(17) 28" (710 mm) Blocks

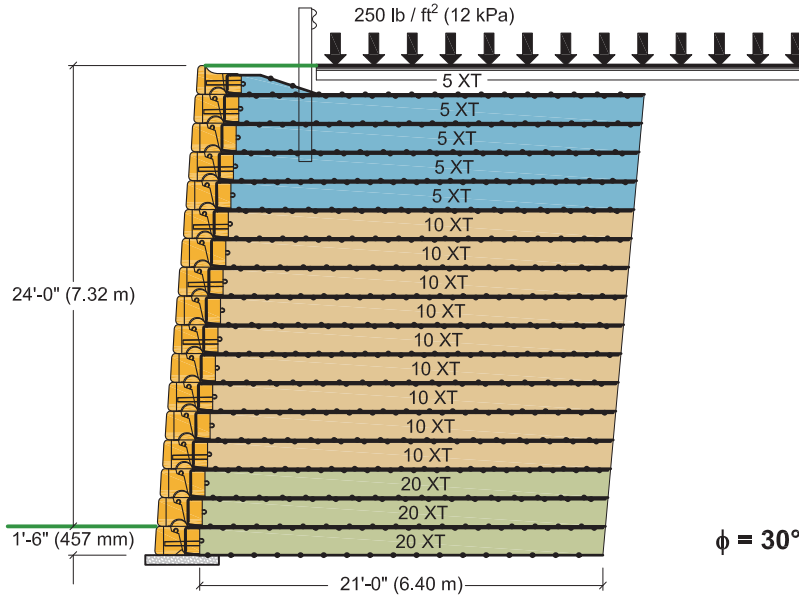
Geogrid Rolls Required per Wall Length		
Type	Rolls / linear ft	Rolls / linear m
5XT	± 0.33	± 1.07
10XT	± 0.59	± 1.92
20XT	± 0.20	± 0.64



**Legend:**

-  = 28" (710mm) BLOCK
-  = 41" (1030 mm) BLOCK

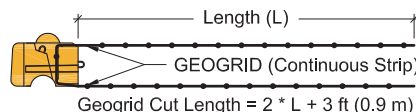

Geogrid shall be 12" (305 mm) wide strips of Mirafi geogrid, type as noted. Geogrid shall be **factory cut** and **certified** for width and strength by TenCate Mirafi.

**SEE NOTES AND RECOMMENDED DETAILS AT START OF PRELIM. REINFORCEMENT SCHEDULE.**

# Preliminary Reinforcement Schedule

$\phi = 30^\circ$  | FINE TO MEDIUM SAND or SILTY SAND

**LOAD CONDITION B** | 250 lb/ft<sup>2</sup> (12 kPa) LIVE LOAD SURCHARGE, NO BACK SLOPE, NO TOE SLOPE

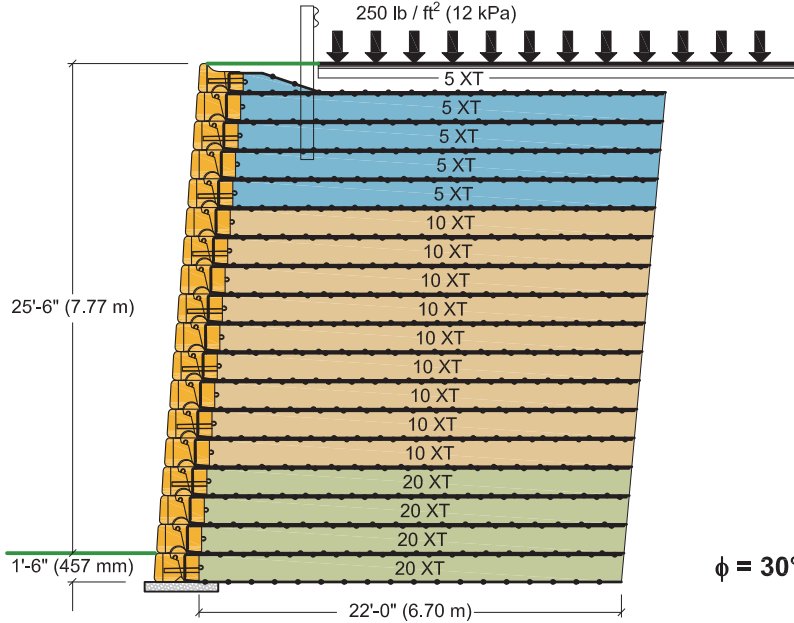

18 BLOCK SECTION  
(18) 28" (710 mm) Blocks

Geogrid Rolls Required per Wall Length		
Type	Rolls / linear ft	Rolls / linear m
5XT	± 0.33	± 1.07
10XT	± 0.59	± 1.92
20XT	± 0.26	± 0.85



$\phi = 30^\circ$

**Legend:**

-  = 28" (710mm) BLOCK
-  = 41" (1030 mm) BLOCK

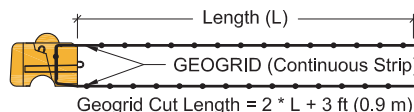

Geogrid shall be 12" (305 mm) wide strips of Mirafi geogrid, type as noted. Geogrid shall be **factory cut** and **certified** for width and strength by TenCate Mirafi.

**SEE NOTES AND RECOMMENDED DETAILS AT START OF PRELIM. REINFORCEMENT SCHEDULE.**

# Preliminary Reinforcement Schedule

$\phi = 30^\circ$  | FINE TO MEDIUM SAND or SILTY SAND



**LOAD CONDITION B** | 250 lb/ft<sup>2</sup> (12 kPa) LIVE LOAD SURCHARGE, NO BACK SLOPE, NO TOE SLOPE

19 BLOCK SECTION  
(19) 28" (710 mm) Blocks

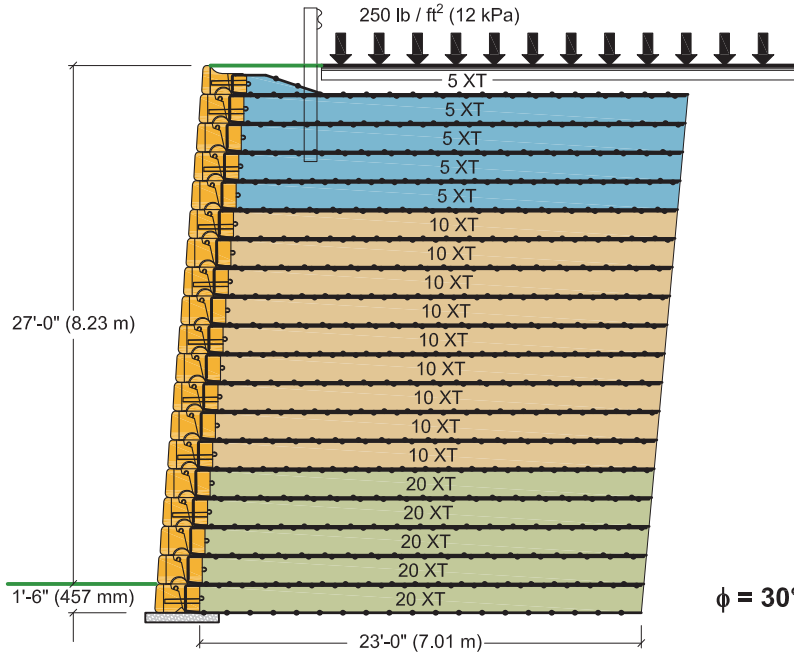
Geogrid Rolls Required per Wall Length		
Type	Rolls / linear ft	Rolls / linear m
5XT	± 0.33	± 1.07
10XT	± 0.59	± 1.92
20XT	± 0.33	± 1.07



**Legend:**

-  = 28" (710mm) BLOCK
-  = 41" (1030 mm) BLOCK

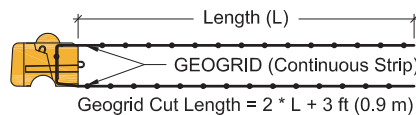

Geogrid shall be 12" (305 mm) wide strips of Mirafi geogrid, type as noted. Geogrid shall be **factory cut** and **certified** for width and strength by TenCate Mirafi.

**SEE NOTES AND RECOMMENDED DETAILS AT START OF PRELIM. REINFORCEMENT SCHEDULE.**

# Preliminary Reinforcement Schedule

$\phi = 30^\circ$  | FINE TO MEDIUM SAND or SILTY SAND

**LOAD CONDITION B** | 250 lb/ft<sup>2</sup> (12 kPa) LIVE LOAD SURCHARGE, NO BACK SLOPE, NO TOE SLOPE

20 BLOCK SECTION \*  
(20) 28" (710 mm) Blocks

Geogrid Rolls Required per Wall Length		
Type	Rolls / linear ft	Rolls / linear m
5XT	± 0.43	± 1.42
10XT	± 0.78	± 2.56
20XT	± 0.52	± 1.71

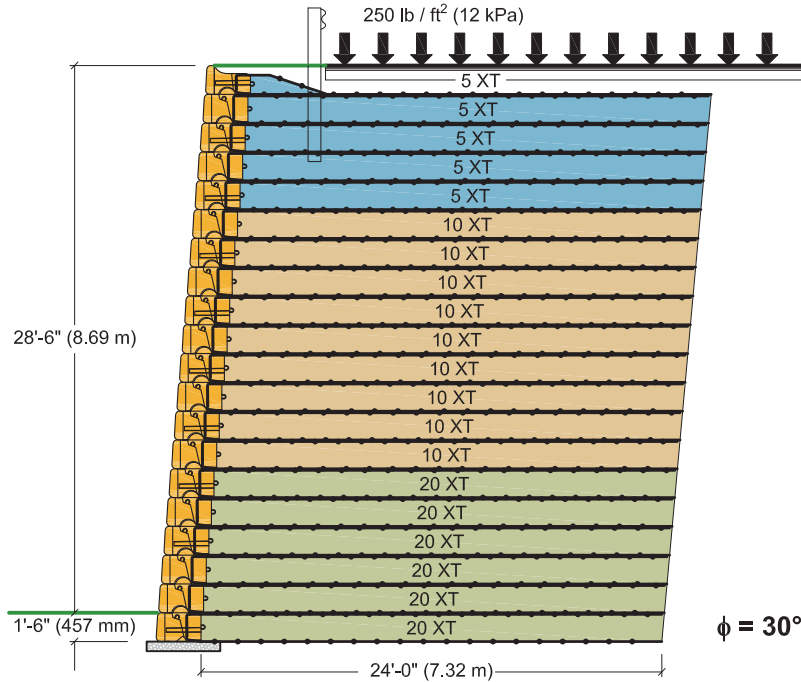

**Legend:**

= 28" (710mm) BLOCK

= 41" (1030 mm) BLOCK

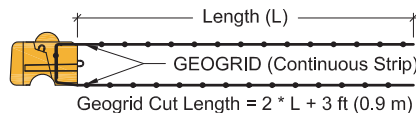

Geogrid shall be 12" (305 mm) wide strips of Mirafi geogrid, type as noted. Geogrid shall be **factory cut** and **certified** for width and strength by TenCate Mirafi.

**\* Not tall enough? You can build significantly taller walls with the Redi-Rock PC System...we just had to stop the preliminary sections somewhere. Talk to your Engineer or give us a call for more info.**

**SEE NOTES AND RECOMMENDED DETAILS AT START OF PRELIM. REINFORCEMENT SCHEDULE.**

# Preliminary Reinforcement Schedule

$\phi = 30^\circ$  | FINE TO MEDIUM SAND or SILTY SAND

**LOAD CONDITION CR** | 1 : 2 CREST SLOPE, 10' (3.0 m) HIGH, 250 lb/ft<sup>2</sup> (12 kPa) SURCHARGE AT CREST, NO TOE SLOPE

2 BLOCK HIGH SECTION  
(2) 28" (710 mm) Blocks

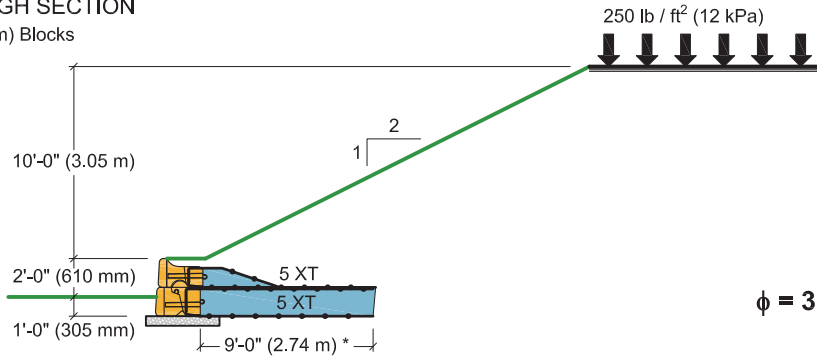

Geogrid Rolls Required per Wall Length		
Type	Rolls / linear ft	Rolls / linear m
5XT	± 0.06	± 0.19

3 BLOCK HIGH SECTION  
(3) 28" (710 mm) Blocks

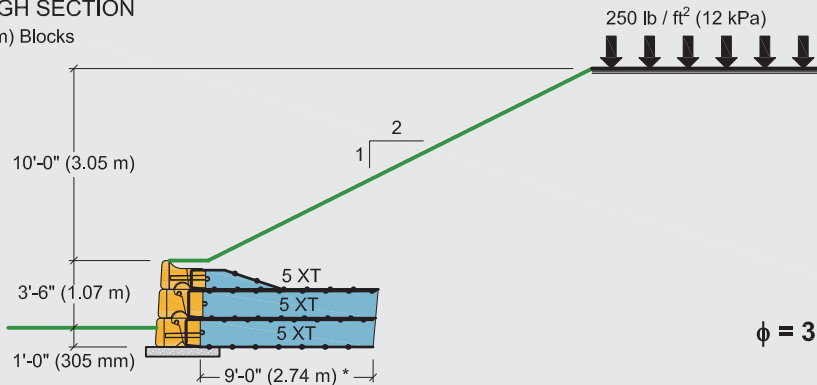

Geogrid Rolls Required per Wall Length		
Type	Rolls / linear ft	Rolls / linear m
5XT	± 0.09	± 0.28

4 BLOCK HIGH SECTION  
(4) 28" (710 mm) Blocks

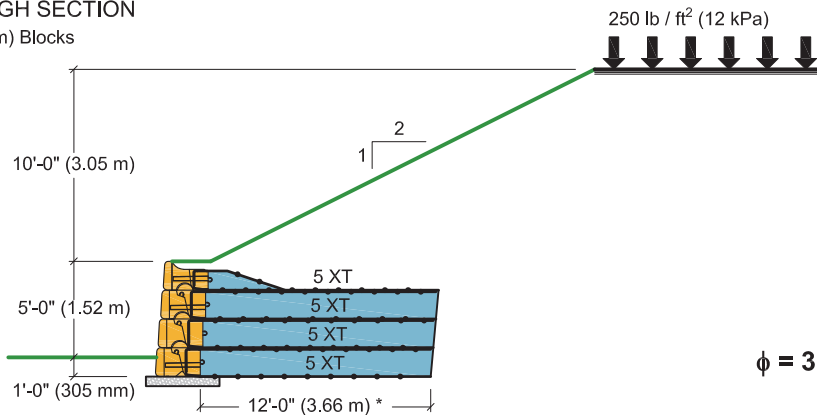

Geogrid Rolls Required per Wall Length		
Type	Rolls / linear ft	Rolls / linear m
5XT	± 0.15	± 0.49

**Legend:**

= 28" (710mm) BLOCK

= 41" (1030 mm) BLOCK

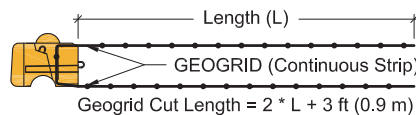

Geogrid shall be 12" (305 mm) wide strips of Mirafi geogrid, type as noted. Geogrid shall be **factory cut** and **certified** for width and strength by TenCate Mirafi.

\* Geogrid length primarily controlled by global stability. Length will change with crest height.

**SEE NOTES AND RECOMMENDED DETAILS AT START OF PRELIM. REINFORCEMENT SCHEDULE.**

# Preliminary Reinforcement Schedule

$\phi = 30^\circ$  | FINE TO MEDIUM SAND or SILTY SAND

**LOAD CONDITION CR** | 1 : 2 CREST SLOPE, 10' (3.0 m) HIGH, 250 lb/ft<sup>2</sup> (12 kPa) SURCHARGE AT CREST, NO TOE SLOPE

5 BLOCK HIGH SECTION  
(5) 28" (710 mm) Blocks

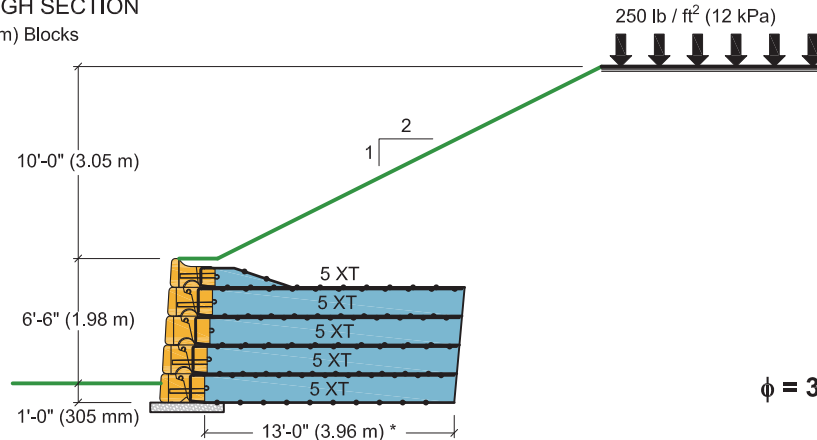

Geogrid Rolls Required per Wall Length		
Type	Rolls / linear ft	Rolls / linear m
5XT	± 0.22	± 0.71

6 BLOCK HIGH SECTION  
(6) 28" (710 mm) Blocks

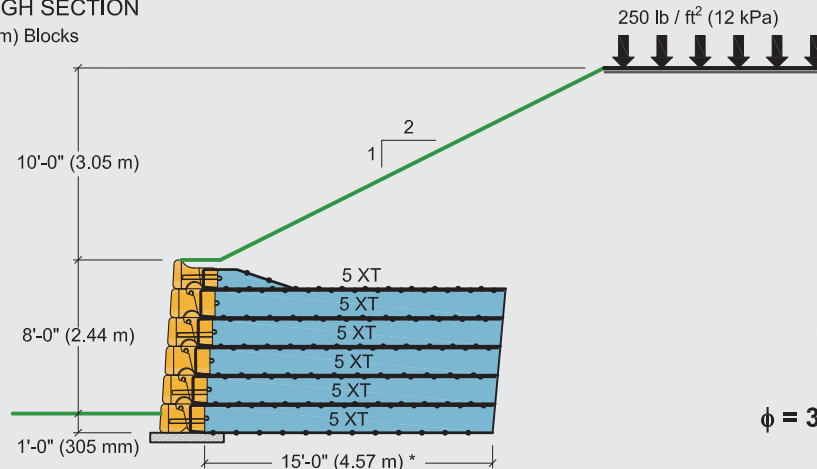

Geogrid Rolls Required per Wall Length		
Type	Rolls / linear ft	Rolls / linear m
5XT	± 0.26	± 0.85

**Legend:**

= 28" (710mm) BLOCK

= 41" (1030 mm) BLOCK

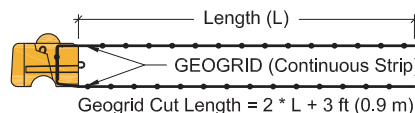

Geogrid shall be 12" (305 mm) wide strips of Mirafi geogrid, type as noted. Geogrid shall be **factory cut** and **certified** for width and strength by TenCate Mirafi.

**\* Geogrid length primarily controlled by global stability. Length will change with crest height.**

**SEE NOTES AND RECOMMENDED DETAILS AT START OF PRELIM. REINFORCEMENT SCHEDULE.**

# Preliminary Reinforcement Schedule

$\phi = 30^\circ$  | FINE TO MEDIUM SAND or SILTY SAND

**LOAD CONDITION CR** | 1 : 2 CREST SLOPE, 10' (3.0 m) HIGH, 250 lb/ft<sup>2</sup> (12 kPa) SURCHARGE AT CREST, NO TOE SLOPE

7 BLOCK HIGH SECTION  
(7) 28" (710 mm) Blocks

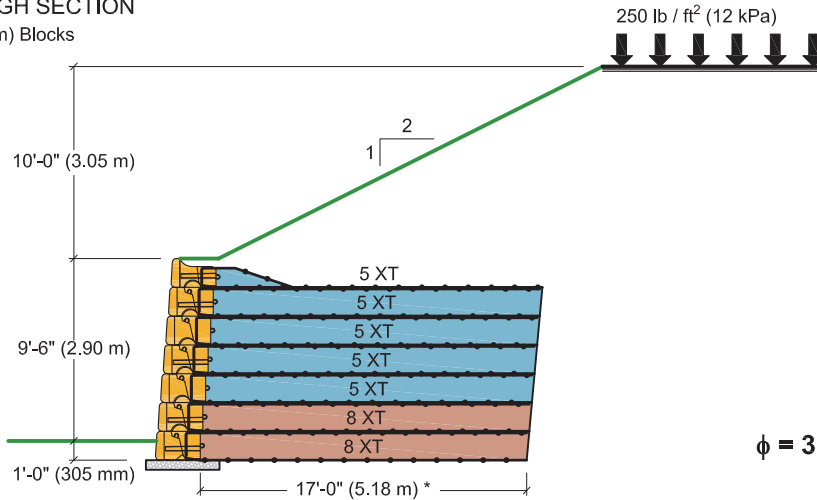

Geogrid Rolls Required per Wall Length		
Type	Rolls / linear ft	Rolls / linear m
5XT	± 0.26	± 0.85
8XT	± 0.10	± 0.34

8 BLOCK HIGH SECTION  
(8) 28" (710 mm) Blocks

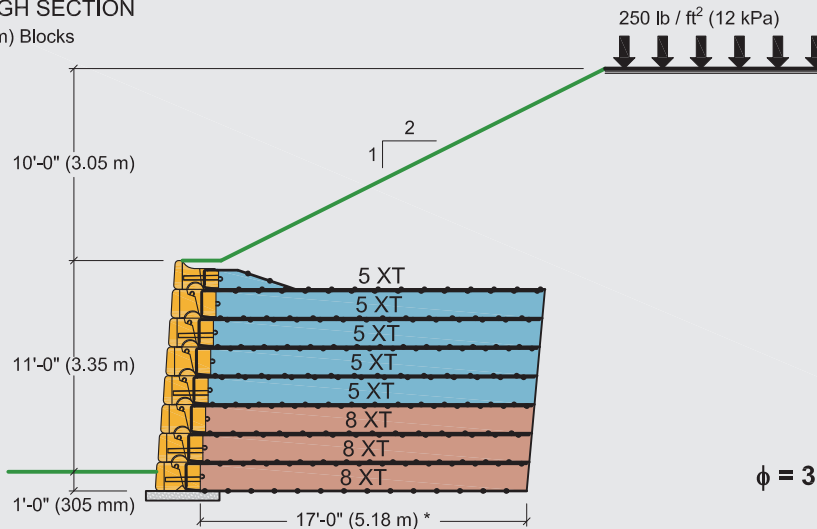

Geogrid Rolls Required per Wall Length		
Type	Rolls / linear ft	Rolls / linear m
5XT	± 0.26	± 0.85
8XT	± 0.16	± 0.51

**Legend:**

= 28" (710mm) BLOCK

= 41" (1030 mm) BLOCK

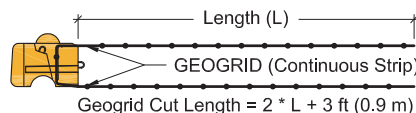

Geogrid shall be 12" (305 mm) wide strips of Mirafi geogrid, type as noted. Geogrid shall be **factory cut** and **certified** for width and strength by TenCate Mirafi.

**\* Geogrid length primarily controlled by global stability. Length will change with crest height.**

**SEE NOTES AND RECOMMENDED DETAILS AT START OF PRELIM. REINFORCEMENT SCHEDULE.**

# Preliminary Reinforcement Schedule

$\phi = 30^\circ$  | FINE TO MEDIUM SAND or SILTY SAND

**LOAD CONDITION CR** | 1 : 2 CREST SLOPE, 10' (3.0 m) HIGH, 250 lb/ft<sup>2</sup> (12 kPa) SURCHARGE AT CREST, NO TOE SLOPE

9 BLOCK HIGH SECTION  
(9) 28" (710 mm) Blocks

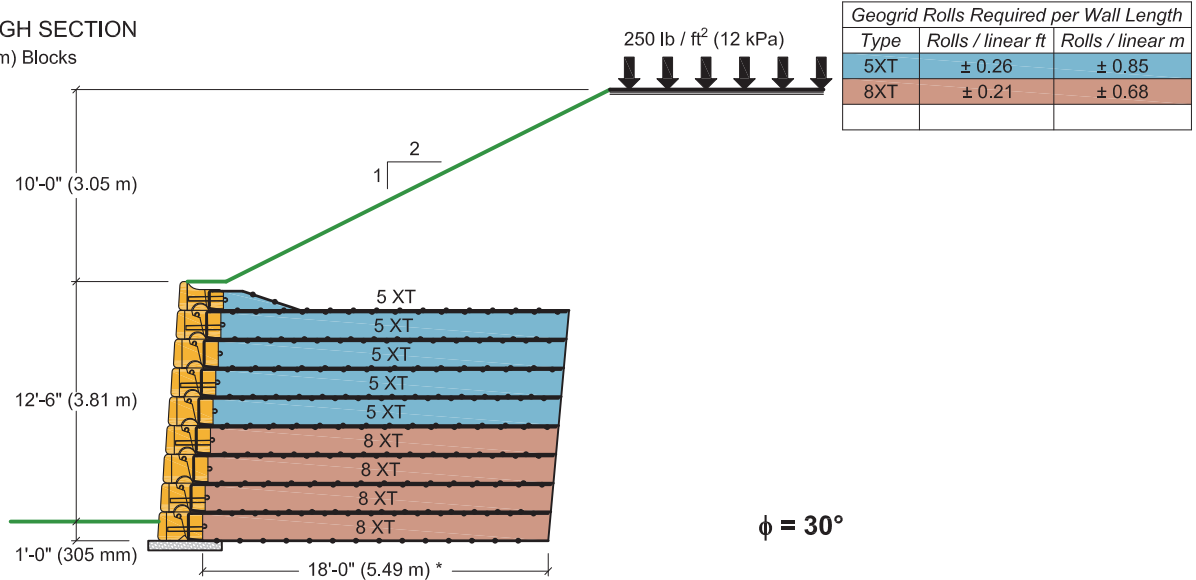

10 BLOCK HIGH SECTION  
(10) 28" (710 mm) Blocks

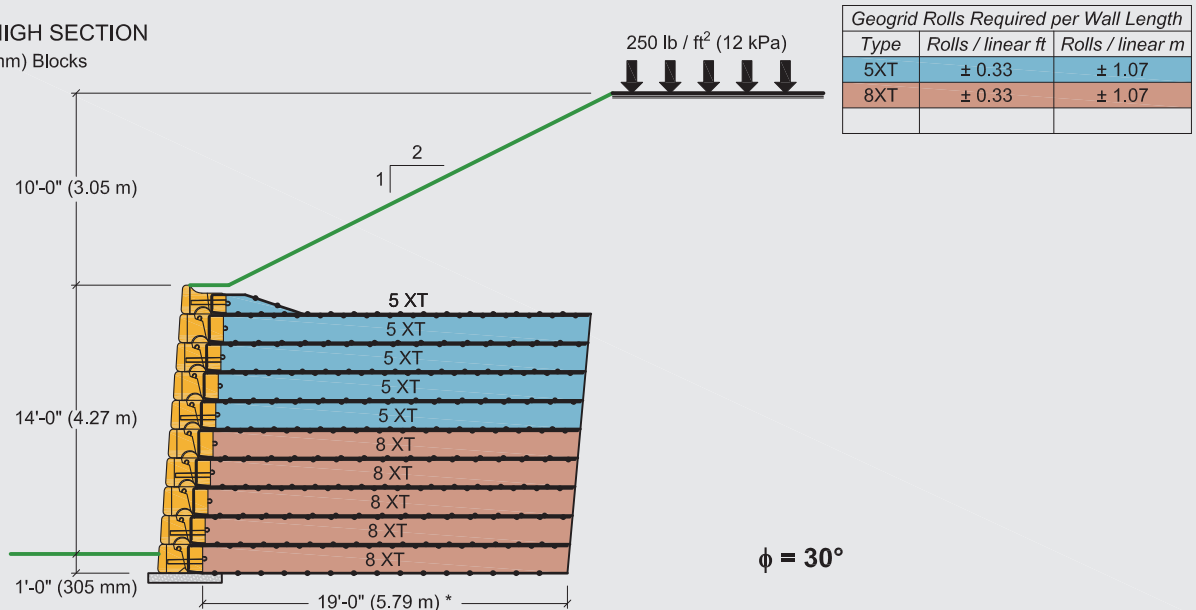

**Legend:**

 = 28" (710mm) BLOCK

 = 41" (1030 mm) BLOCK

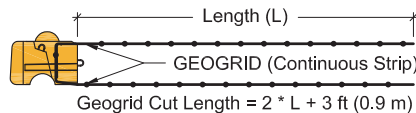

Geogrid shall be 12" (305 mm) wide strips of Mirafi geogrid, type as noted. Geogrid shall be **factory cut** and **certified** for width and strength by TenCate Mirafi.

**\* Geogrid length primarily controlled by global stability. Length will change with crest height.**

**SEE NOTES AND RECOMMENDED DETAILS AT START OF PRELIM. REINFORCEMENT SCHEDULE.**

# Preliminary Reinforcement Schedule

$\phi = 30^\circ$  | FINE TO MEDIUM SAND or SILTY SAND

**LOAD CONDITION CR** | 1 : 2 CREST SLOPE, 10' (3.0 m) HIGH, 250 lb/ft<sup>2</sup> (12 kPa) SURCHARGE AT CREST, NO TOE SLOPE

11 BLOCK HIGH SECTION  
(11) 28" (710 mm) Blocks

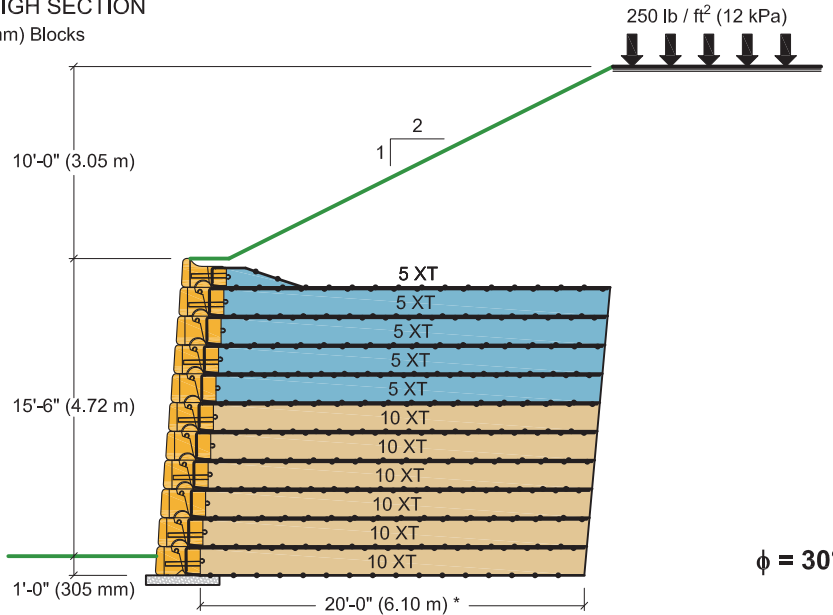

Geogrid Rolls Required per Wall Length		
Type	Rolls / linear ft	Rolls / linear m
5XT	± 0.33	± 1.07
10XT	± 0.39	± 1.28

12 BLOCK HIGH SECTION  
(12) 28" (710 mm) Blocks

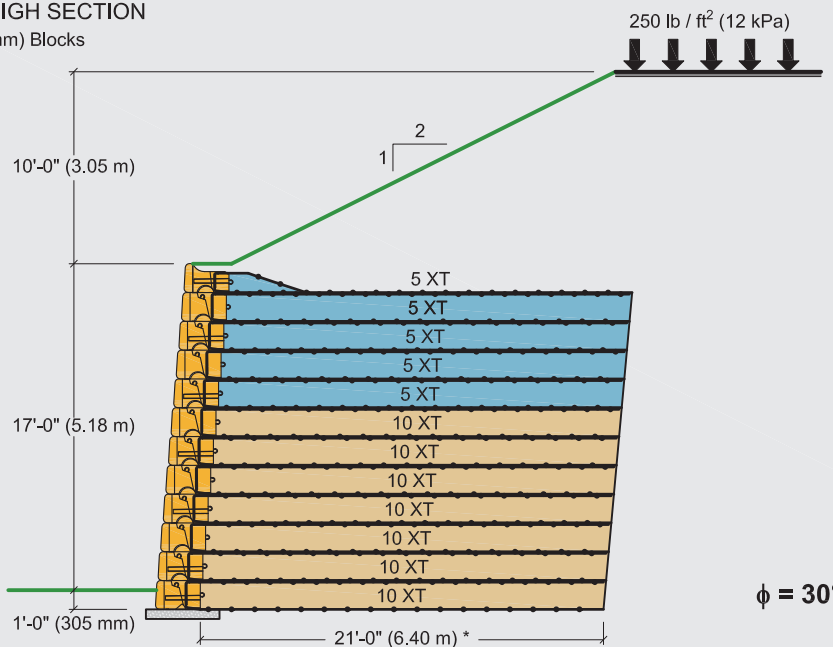

Geogrid Rolls Required per Wall Length		
Type	Rolls / linear ft	Rolls / linear m
5XT	± 0.33	± 1.07
10XT	± 0.46	± 1.49

**Legend:**

= 28" (710mm) BLOCK

= 41" (1030 mm) BLOCK

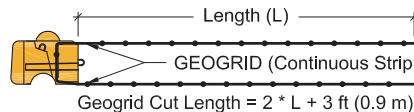

Geogrid shall be 12" (305 mm) wide strips of Mirafi geogrid, type as noted. Geogrid shall be **factory cut** and **certified** for width and strength by TenCate Mirafi.

\* **Geogrid length primarily controlled by global stability. Length will change with crest height.**

**SEE NOTES AND RECOMMENDED DETAILS AT START OF PRELIM. REINFORCEMENT SCHEDULE.**

# Preliminary Reinforcement Schedule

$\phi = 30^\circ$  | FINE TO MEDIUM SAND or SILTY SAND

**LOAD CONDITION CR** | 1 : 2 CREST SLOPE, 10' (3.0 m) HIGH, 250 lb/ft<sup>2</sup> (12 kPa) SURCHARGE AT CREST, NO TOE SLOPE

13 BLOCK HIGH SECTION  
(13) 28" (710 mm) Blocks

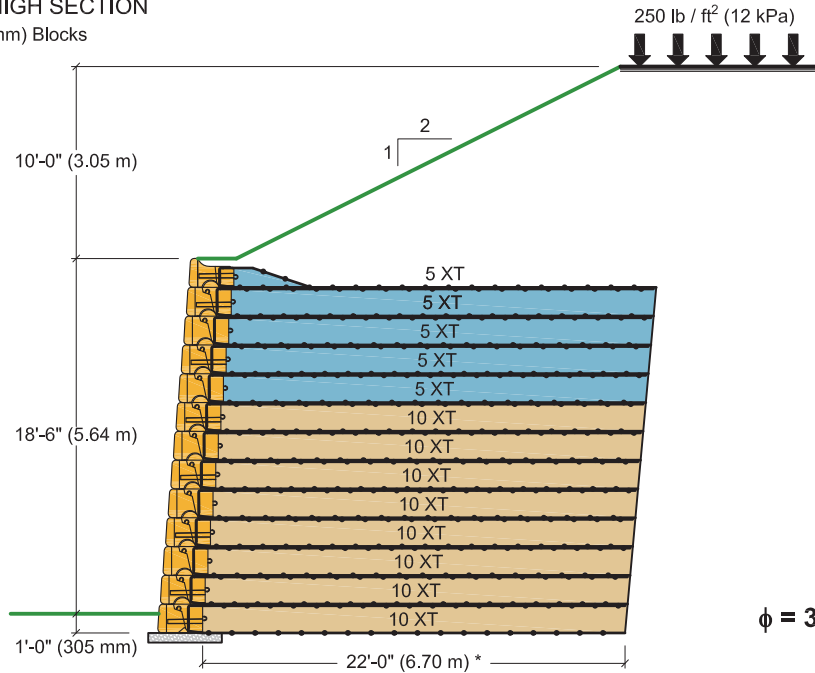

Geogrid Rolls Required per Wall Length		
Type	Rolls / linear ft	Rolls / linear m
5XT	± 0.33	± 1.07
10XT	± 0.52	± 1.71

**Legend:**

= 28" (710mm) BLOCK

= 41" (1030 mm) BLOCK

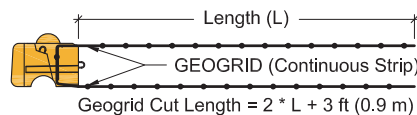

Geogrid shall be 12" (305 mm) wide strips of Mirafi geogrid, type as noted. Geogrid shall be **factory cut** and **certified** for width and strength by TenCate Mirafi.

\* Geogrid length primarily controlled by global stability. Length will change with crest height.

**SEE NOTES AND RECOMMENDED DETAILS AT START OF PRELIM. REINFORCEMENT SCHEDULE.**

# Preliminary Reinforcement Schedule

$\phi = 30^\circ$  | FINE TO MEDIUM SAND or SILTY SAND

**LOAD CONDITION CR** | 1 : 2 CREST SLOPE, 10' (3.0 m) HIGH, 250 lb/ft<sup>2</sup> (12 kPa) SURCHARGE AT CREST, NO TOE SLOPE

14 BLOCK HIGH SECTION  
(14) 28" (710 mm) Blocks

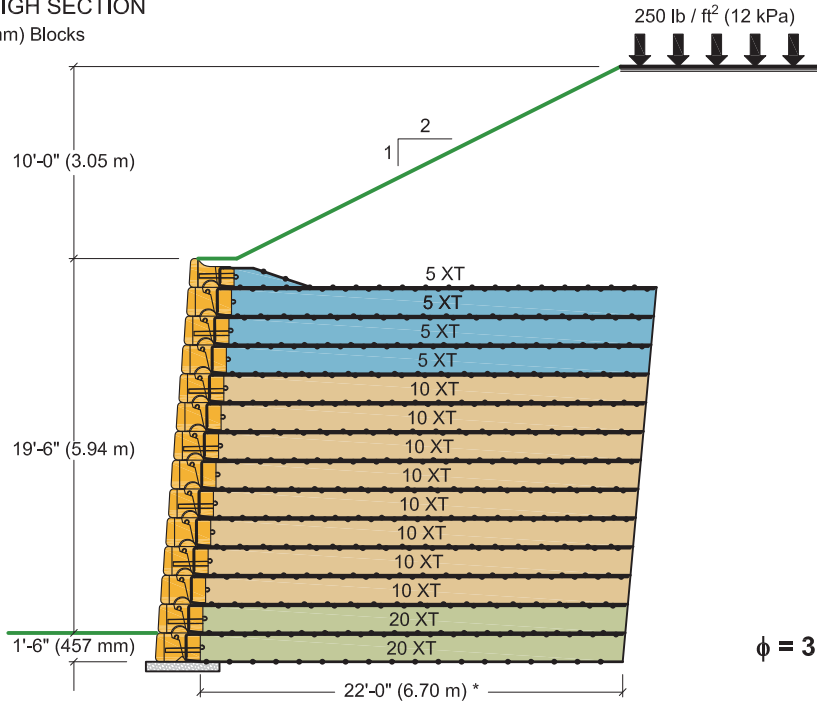

Geogrid Rolls Required per Wall Length		
Type	Rolls / linear ft	Rolls / linear m
5XT	± 0.26	± 0.85
10XT	± 0.52	± 1.71
20XT	± 0.13	± 0.43

$\phi = 30^\circ$

**Legend:**

- = 28" (710mm) BLOCK
- = 41" (1030 mm) BLOCK

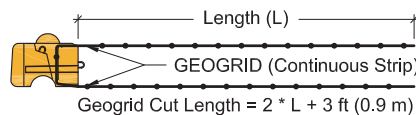

Geogrid shall be 12" (305 mm) wide strips of Mirafi geogrid, type as noted. Geogrid shall be **factory cut** and **certified** for width and strength by TenCate Mirafi.

\* Geogrid length primarily controlled by global stability. Length will change with crest height.

**SEE NOTES AND RECOMMENDED DETAILS AT START OF PRELIM. REINFORCEMENT SCHEDULE.**

# Preliminary Reinforcement Schedule

$\phi = 30^\circ$  | FINE TO MEDIUM SAND or SILTY SAND

**LOAD CONDITION CR** | 1 : 2 CREST SLOPE, 10' (3.0 m) HIGH, 250 lb/ft<sup>2</sup> (12 kPa) SURCHARGE AT CREST, NO TOE SLOPE

15 BLOCK HIGH SECTION  
(15) 28" (710 mm) Blocks

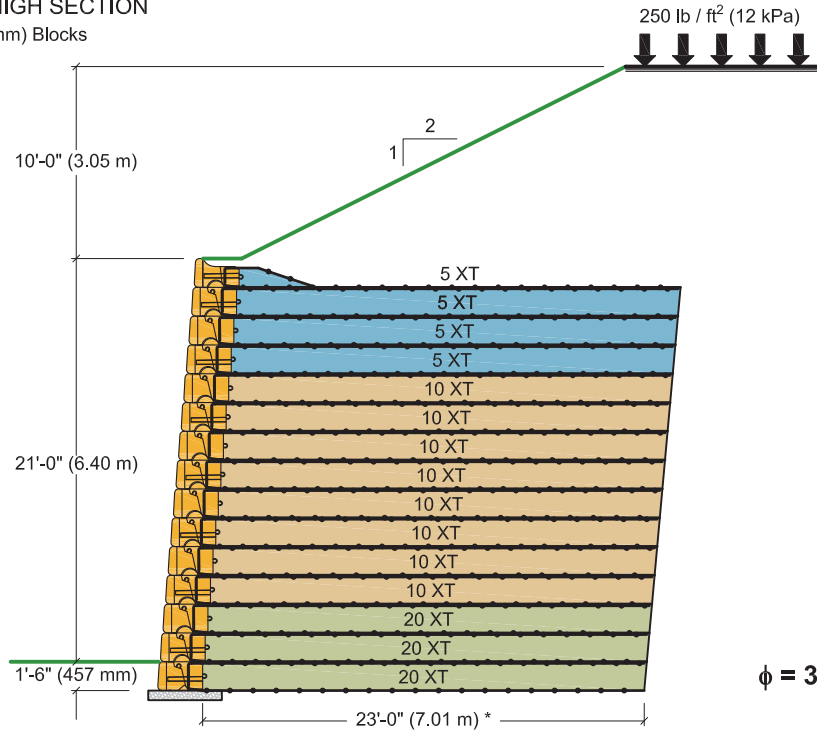

Geogrid Rolls Required per Wall Length		
Type	Rolls / linear ft	Rolls / linear m
5XT	± 0.26	± 0.85
10XT	± 0.52	± 1.71
20XT	± 0.20	± 0.64

$\phi = 30^\circ$

**Legend:**

= 28" (710mm) BLOCK

= 41" (1030 mm) BLOCK

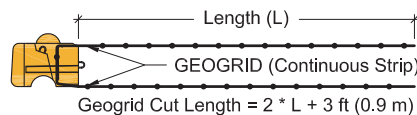

Geogrid shall be 12" (305 mm) wide strips of Mirafi geogrid, type as noted. Geogrid shall be **factory cut** and **certified** for width and strength by TenCate Mirafi.

**\* Geogrid length primarily controlled by global stability. Length will change with crest height.**

**SEE NOTES AND RECOMMENDED DETAILS AT START OF PRELIM. REINFORCEMENT SCHEDULE.**

# Preliminary Reinforcement Schedule

$\phi = 30^\circ$  | FINE TO MEDIUM SAND or SILTY SAND

**LOAD CONDITION CR** | 1 : 2 CREST SLOPE, 10' (3.0 m) HIGH, 250 lb/ft<sup>2</sup> (12 kPa) SURCHARGE AT CREST, NO TOE SLOPE

16 BLOCK HIGH SECTION  
(16) 28" (710 mm) Blocks

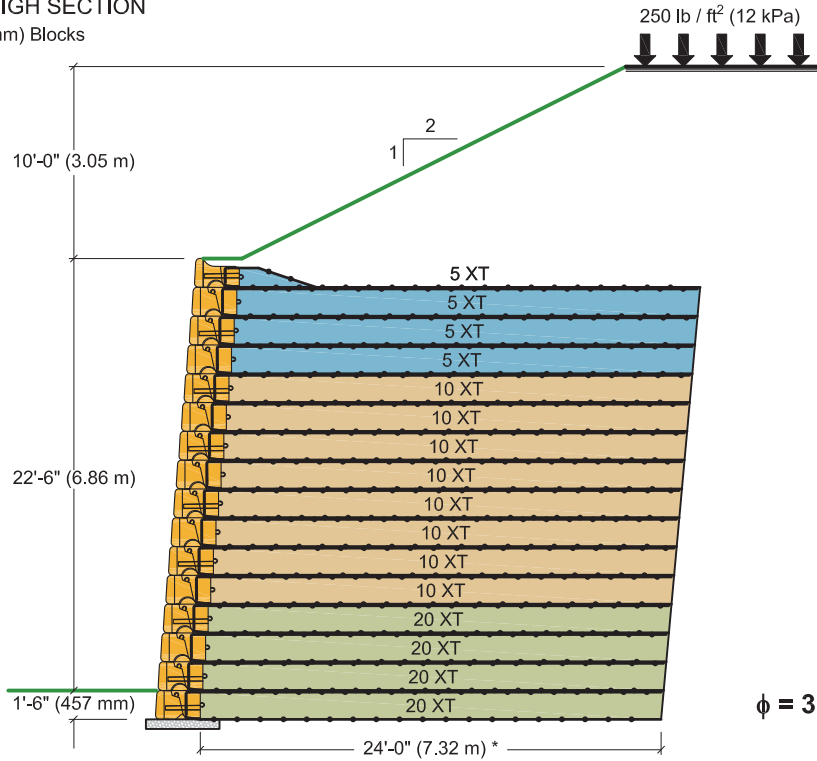

Geogrid Rolls Required per Wall Length		
Type	Rolls / linear ft	Rolls / linear m
5XT	± 0.35	± 1.14
10XT	± 0.69	± 2.28
20XT	± 0.35	± 1.14

**Legend:**

- = 28" (710mm) BLOCK
- = 41" (1030 mm) BLOCK

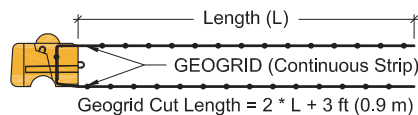

Geogrid shall be 12" (305 mm) wide strips of Mirafi geogrid, type as noted. Geogrid shall be **factory cut** and **certified** for width and strength by TenCate Mirafi.

\* Geogrid length primarily controlled by global stability. Length will change with crest height.

**SEE NOTES AND RECOMMENDED DETAILS AT START OF PRELIM. REINFORCEMENT SCHEDULE.**

# Preliminary Reinforcement Schedule

$\phi = 30^\circ$  | FINE TO MEDIUM SAND or SILTY SAND

**LOAD CONDITION CR** | 1 : 2 CREST SLOPE, 10' (3.0 m) HIGH, 250 lb/ft<sup>2</sup> (12 kPa) SURCHARGE AT CREST, NO TOE SLOPE

17 BLOCK HIGH SECTION  
(17) 28" (710 mm) Blocks

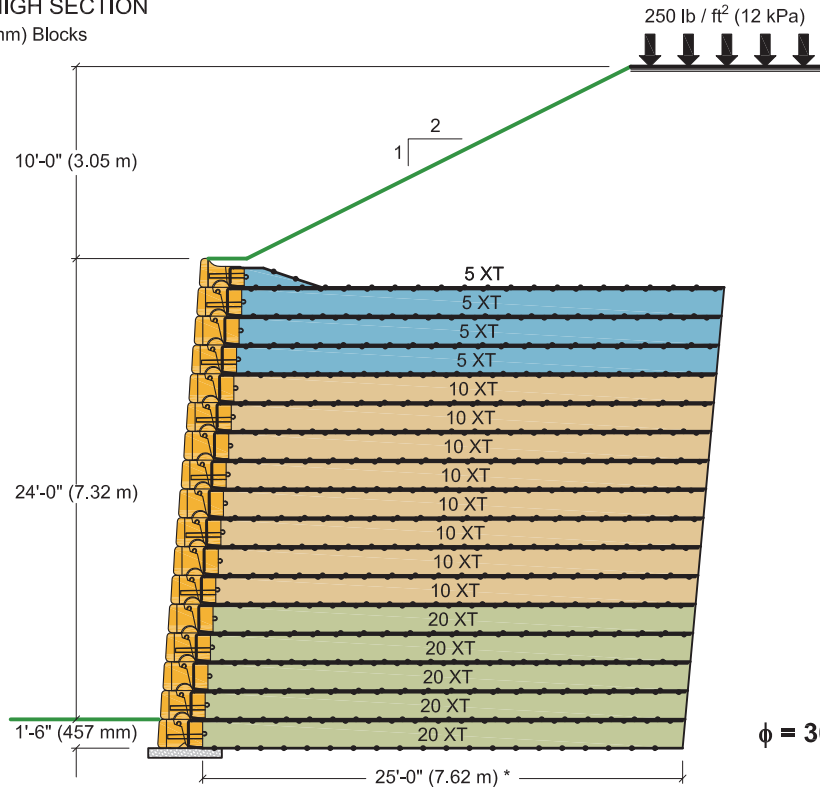

Geogrid Rolls Required per Wall Length		
Type	Rolls / linear ft	Rolls / linear m
5XT	± 0.35	± 1.14
10XT	± 0.69	± 2.28
20XT	± 0.43	± 1.42

**Legend:**

= 28" (710mm) BLOCK

= 41" (1030 mm) BLOCK

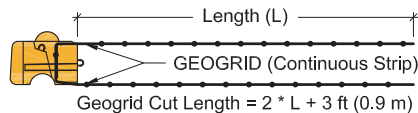

Geogrid shall be 12" (305 mm) wide strips of Mirafi geogrid, type as noted. Geogrid shall be **factory cut** and **certified** for width and strength by TenCate Mirafi.

\* Geogrid length primarily controlled by global stability. Length will change with crest height.

**SEE NOTES AND RECOMMENDED DETAILS AT START OF PRELIM. REINFORCEMENT SCHEDULE.**

# Preliminary Reinforcement Schedule

$\phi = 30^\circ$  | FINE TO MEDIUM SAND or SILTY SAND

**LOAD CONDITION CR** | 1 : 2 CREST SLOPE, 10' (3.0 m) HIGH, 250 lb/ft<sup>2</sup> (12 kPa) SURCHARGE AT CREST, NO TOE SLOPE

18 BLOCK HIGH SECTION  
(18) 28" (710 mm) Blocks

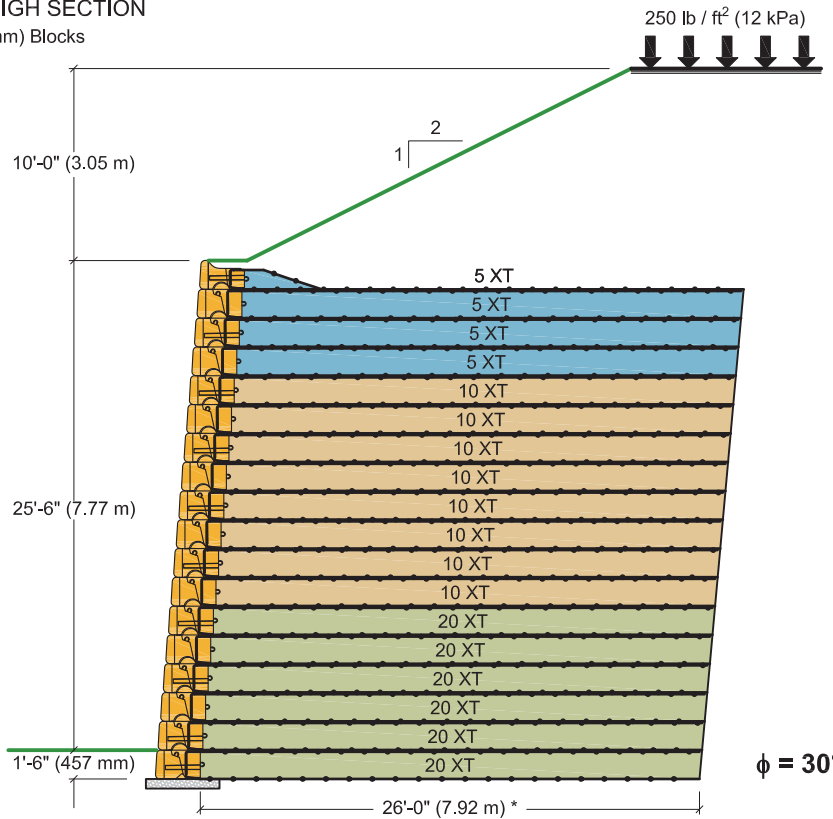

Geogrid Rolls Required per Wall Length		
Type	Rolls / linear ft	Rolls / linear m
5XT	± 0.35	± 1.14
10XT	± 0.69	± 2.28
20XT	± 0.52	± 1.71

**Legend:**

- = 28" (710mm) BLOCK
- = 41" (1030 mm) BLOCK

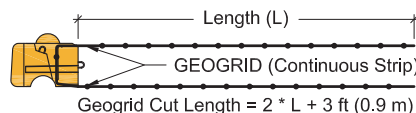

Geogrid shall be 12" (305 mm) wide strips of Mirafi geogrid, type as noted. Geogrid shall be **factory cut** and **certified** for width and strength by TenCate Mirafi.

**\* Geogrid length primarily controlled by global stability. Length will change with crest height.**

**SEE NOTES AND RECOMMENDED DETAILS AT START OF PRELIM. REINFORCEMENT SCHEDULE.**

# Preliminary Reinforcement Schedule

$\phi = 30^\circ$  | FINE TO MEDIUM SAND or SILTY SAND

**LOAD CONDITION CR** | 1 : 2 CREST SLOPE, 10' (3.0 m) HIGH, 250 lb/ft<sup>2</sup> (12 kPa) SURCHARGE AT CREST, NO TOE SLOPE

19 BLOCK HIGH SECTION  
(19) 28" (710 mm) Blocks

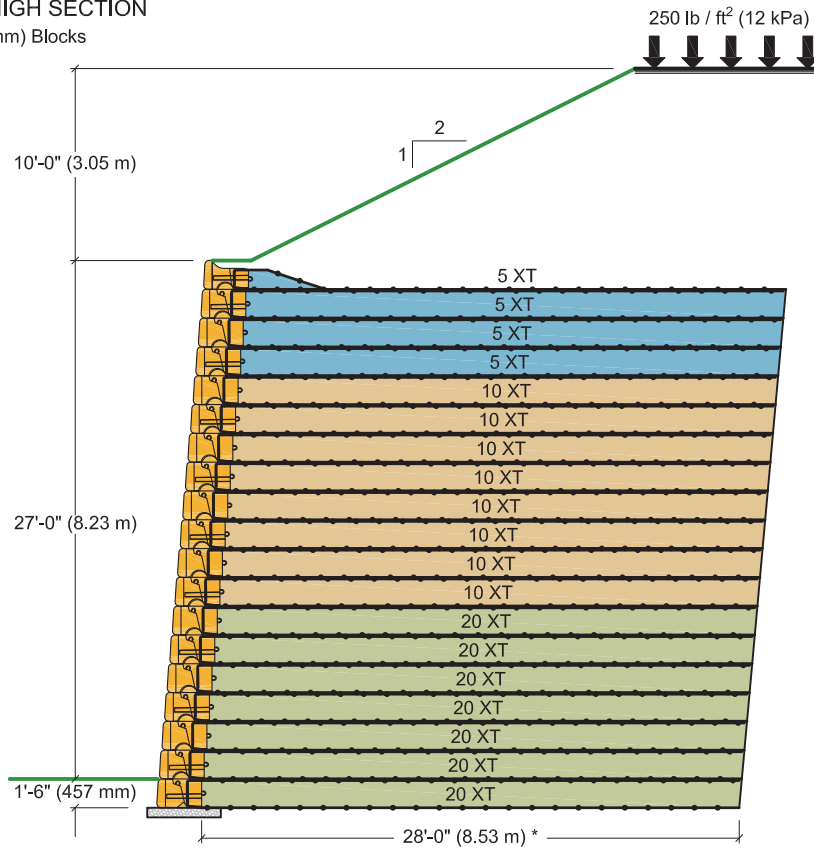

Geogrid Rolls Required per Wall Length		
Type	Rolls / linear ft	Rolls / linear m
5XT	± 0.35	± 1.14
10XT	± 0.69	± 2.28
20XT	± 0.61	± 1.99

**Legend:**

= 28" (710mm) BLOCK

= 41" (1030 mm) BLOCK

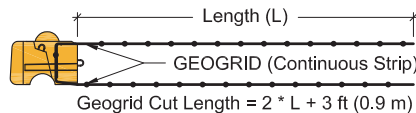

Geogrid shall be 12" (305 mm) wide strips of Mirafi geogrid, type as noted. Geogrid shall be **factory cut** and **certified** for width and strength by TenCate Mirafi.

**\* Geogrid length primarily controlled by global stability. Length will change with crest height.**

**SEE NOTES AND RECOMMENDED DETAILS AT START OF PRELIM. REINFORCEMENT SCHEDULE.**

# Preliminary Reinforcement Schedule

$\phi = 30^\circ$  | FINE TO MEDIUM SAND or SILTY SAND

**LOAD CONDITION CR** | 1 : 2 CREST SLOPE, 10' (3.0 m) HIGH, 250 lb/ft<sup>2</sup> (12 kPa) SURCHARGE AT CREST, NO TOE SLOPE

20 BLOCK HIGH SECTION \*\*  
(20) 28" (710 mm) Blocks

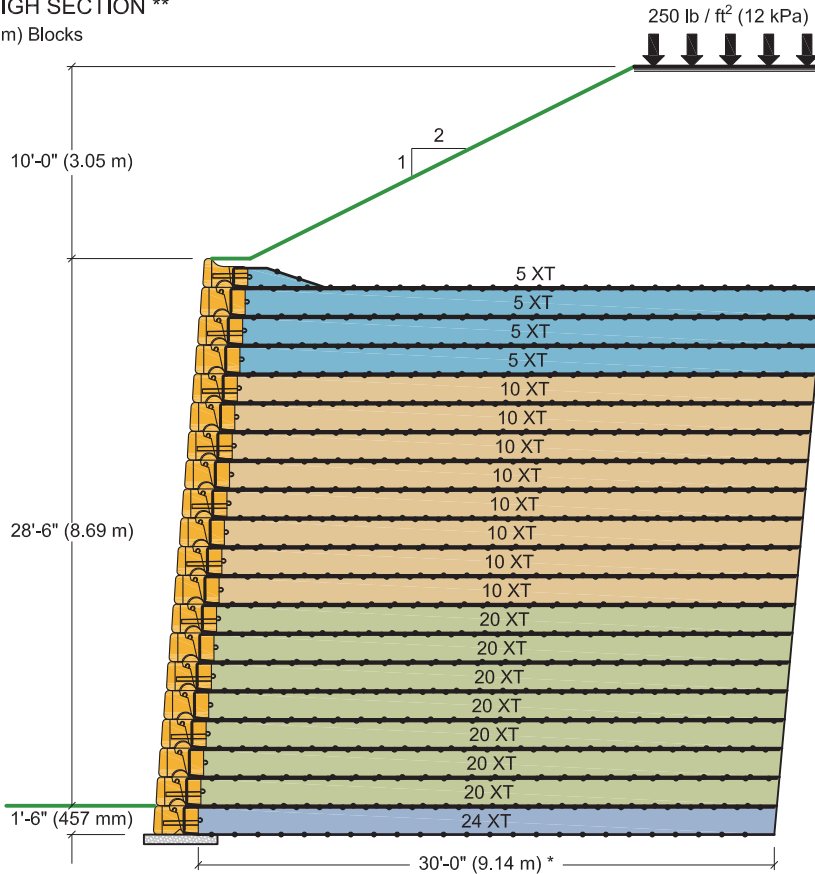

Geogrid Rolls Required per Wall Length		
Type	Rolls / linear ft	Rolls / linear m
5XT	± 0.35	± 1.14
10XT	± 0.69	± 2.28
20XT	± 0.61	± 1.99
24XT	± 0.09	± 0.28

**Legend:**

= 28" (710mm) BLOCK

= 41" (1030 mm) BLOCK

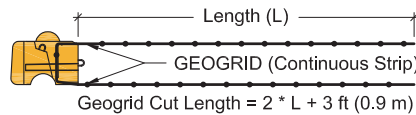

Geogrid shall be 12" (305 mm) wide strips of Mirafi geogrid, type as noted. Geogrid shall be **factory cut** and **certified** for width and strength by TenCate Mirafi.

\* **Geogrid length primarily controlled by global stability. Length will change with crest height.**

\*\* **Not tall enough? You can build significantly taller walls with the Redi-Rock PC System...we just had to stop the preliminary sections somewhere. Talk to your Engineer or give us a call for more info.**

**SEE NOTES AND RECOMMENDED DETAILS AT START OF PRELIM. REINFORCEMENT SCHEDULE.**

# Preliminary Reinforcement Schedule

$\phi = 28^\circ$  | SILTY SAND or CLAYEY SAND

Positive Connection System MSE Walls	SECTION 3 OF 3
Assumed reinforced zone, retained, and foundation soils for this Section <sup>(1)</sup>	SM, SC
Internal angle of friction	$\phi = 28^\circ$
Unit weight	$\gamma = 120 \text{ lb / ft}^3 \text{ (18.8 kN / m}^3\text{)}$
Cohesion	$c = 0 \text{ lb / ft}^2 \text{ (0 kPa)}$
AASHTO requirements for reinforced zone material <sup>(2)</sup>	
Particles passing 4" (100 mm)	100%
Particles passing the No. 40 (425 $\mu\text{m}$ ) Sieve	0% - 60%
Particles passing the No. 200 (75 $\mu\text{m}$ ) Sieve <sup>(3)</sup>	0% - 15%
Plasticity index of material passing the No. 40 (425 $\mu\text{m}$ ) Sieve	$\leq 6$

<sup>(1)</sup> Assumed material in this section will not typically meet AASHTO requirements for material used in the reinforced soil zone and would need to be replaced with select fill material. Some projects routinely choose to allow the use of on-site soils in the reinforced soil zone. This section of the preliminary reinforcement schedule demonstrates reinforcement requirements for walls that elect to deviate from AASHTO specifications for material in the reinforced soil zone but otherwise design per AASHTO specifications.

<sup>(2)</sup> AASHTO LRFD *Bridge Construction Specifications — 3rd Edition* (2010) Section 7.3.6.3 Structure Backfill for MSE Walls

<sup>(3)</sup> Wall designs electing to deviate from AASHTO specifications and relax this requirement shall not exceed 30% particles passing the No. 200 (75  $\mu\text{m}$ ) Sieve.

**LOAD CONDITION A** | NO LIVE LOAD SURFACE, NO BACK SLOPE, NO TOE SLOPE.....189

**LOAD CONDITION B** | 250 lb/ft<sup>2</sup> (12 kPa) LIVE LOAD SURCHARGE, NO BACK SLOPE, NO TOE SLOPE.....197

**LOAD CONDITION CR** | 1 : 2 CREST SLOPE, 10' (3.0 m) HIGH, 250 lb/ft<sup>2</sup> (12 kPa) LIVE LOAD SURCHARGE AT CREST, NO TOE SLOPE .....207

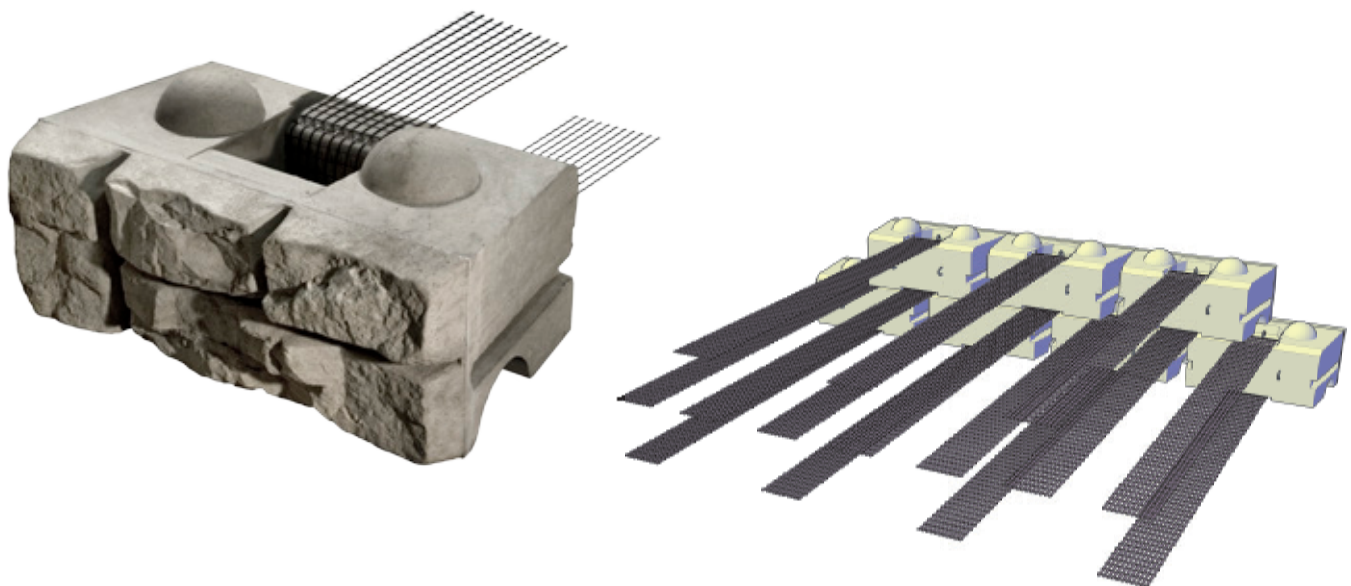

# Preliminary Reinforcement Schedule

$\phi = 28^\circ$  | SILTY SAND or CLAYEY SAND

**LOAD CONDITION A** | NO LIVE LOAD SURCHARGE, NO BACK SLOPE, NO TOE SLOPE

**2 BLOCK SECTION**  
(2) 28" (710 mm) Blocks

Geogrid Rolls Required per Wall Length		
Type	Rolls / linear ft	Rolls / linear m
No Geogrid Needed		

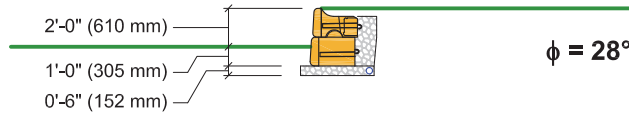

**3 BLOCK SECTION**  
(2) 28" (710 mm) Blocks  
(1) 41" (1030 mm) Block

Geogrid Rolls Required per Wall Length		
Type	Rolls / linear ft	Rolls / linear m
No Geogrid Needed		

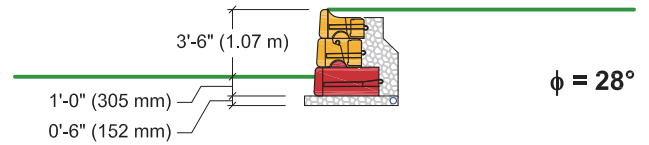

**4 BLOCK SECTION**  
(2) 28" (710 mm) Blocks  
(2) 41" (1030 mm) Blocks

Geogrid Rolls Required per Wall Length		
Type	Rolls / linear ft	Rolls / linear m
No Geogrid Needed		

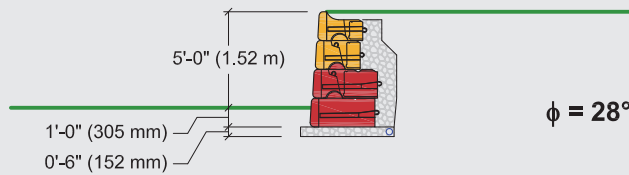

**5 BLOCK SECTION**  
(5) 28" (710 mm) Blocks

Geogrid Rolls Required per Wall Length		
Type	Rolls / linear ft	Rolls / linear m
5XT	± 0.13	± 0.43

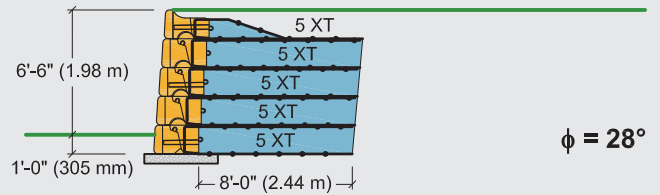

**6 BLOCK SECTION**  
(6) 28" (710 mm) Blocks

Geogrid Rolls Required per Wall Length		
Type	Rolls / linear ft	Rolls / linear m
5XT	± 0.16	± 0.51

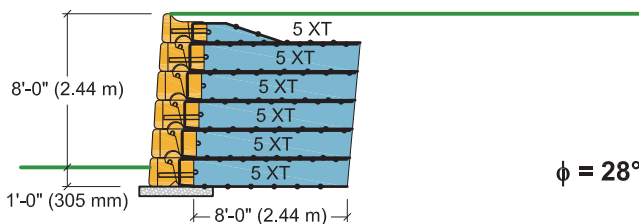

**7 BLOCK SECTION**  
(7) 28" (710 mm) Blocks

Geogrid Rolls Required per Wall Length		
Type	Rolls / linear ft	Rolls / linear m
5XT	± 0.18	± 0.60

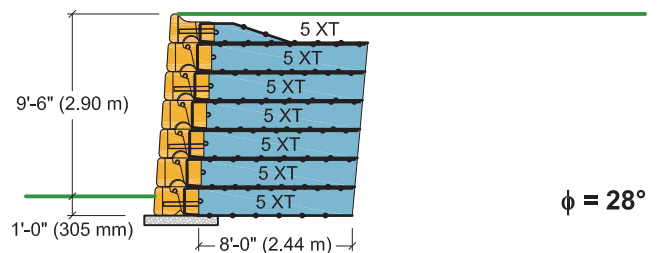

**Legend:**

= 28" (710mm) BLOCK

= 41" (1030 mm) BLOCK

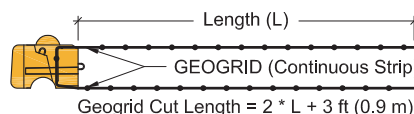

Geogrid shall be 12" (305 mm) wide strips of Mirafi geogrid, type as noted. Geogrid shall be **factory cut** and **certified** for width and strength by TenCate Mirafi.

**SEE NOTES AND RECOMMENDED DETAILS AT START OF PRELIM. REINFORCEMENT SCHEDULE.**

# Preliminary Reinforcement Schedule

$\phi = 28^\circ$  | SILTY SAND or CLAYEY SAND

**LOAD CONDITION A** | NO LIVE LOAD SURCHARGE, NO BACK SLOPE, NO TOE SLOPE

8 BLOCK SECTION  
(8) 28" (710 mm) Blocks

Geogrid Rolls Required per Wall Length		
Type	Rolls / linear ft	Rolls / linear m
5XT	± 0.20	± 0.66
8XT	± 0.03	± 0.09

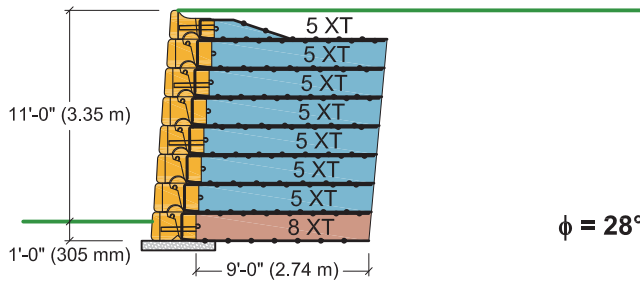

9 BLOCK SECTION  
(9) 28" (710 mm) Blocks

Geogrid Rolls Required per Wall Length		
Type	Rolls / linear ft	Rolls / linear m
5XT	± 0.23	± 0.75
8XT	± 0.07	± 0.21

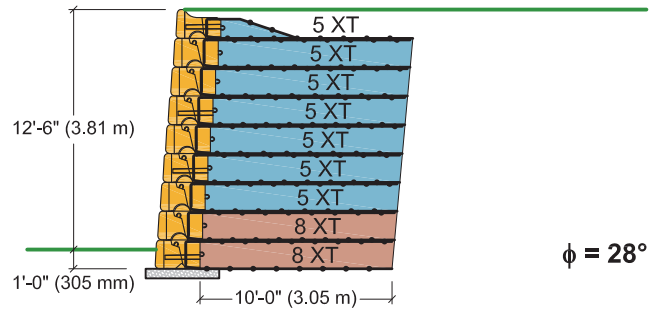

10 BLOCK SECTION  
(10) 28" (710 mm) Blocks

Geogrid Rolls Required per Wall Length		
Type	Rolls / linear ft	Rolls / linear m
5XT	± 0.26	± 0.85
8XT	± 0.11	± 0.37

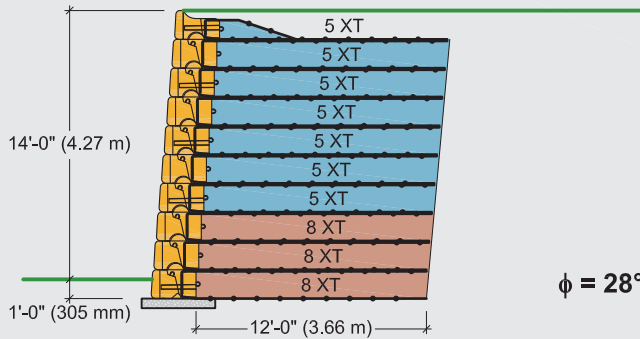

11 BLOCK SECTION  
(11) 28" (710 mm) Blocks

Geogrid Rolls Required per Wall Length		
Type	Rolls / linear ft	Rolls / linear m
5XT	± 0.30	± 1.00
8XT	± 0.17	± 0.57

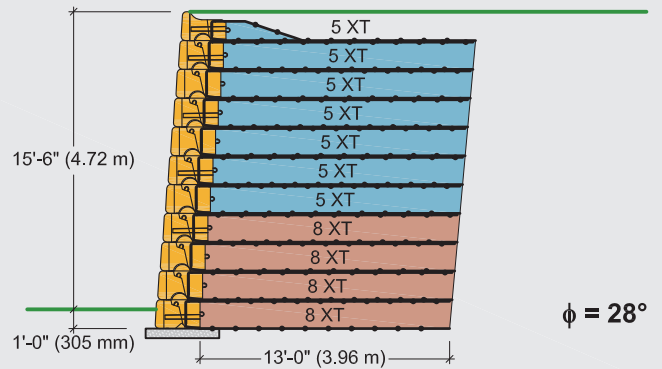

**Legend:**

= 28" (710mm) BLOCK

= 41" (1030 mm) BLOCK

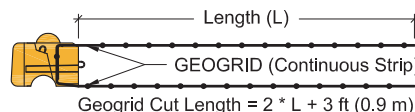

Geogrid shall be 12" (305 mm) wide strips of Mirafi geogrid, type as noted. Geogrid shall be **factory cut** and **certified** for width and strength by TenCate Mirafi.

**SEE NOTES AND RECOMMENDED DETAILS AT START OF PRELIM. REINFORCEMENT SCHEDULE.**

# Preliminary Reinforcement Schedule

$\phi = 28^\circ$  | SILTY SAND or CLAYEY SAND

**LOAD CONDITION A** | NO LIVE LOAD SURCHARGE, NO BACK SLOPE, NO TOE SLOPE

12 BLOCK SECTION  
(12) 28" (710 mm) Blocks

Geogrid Rolls Required per Wall Length		
Type	Rolls / linear ft	Rolls / linear m
5XT	± 0.30	± 1.00
10XT	± 0.22	± 0.71

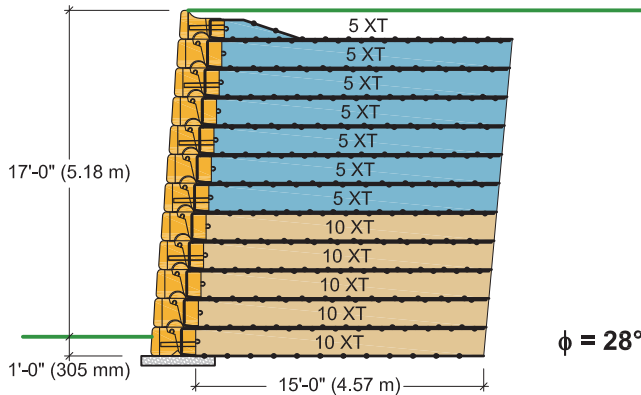

13 BLOCK SECTION  
(13) 28" (710 mm) Blocks

Geogrid Rolls Required per Wall Length		
Type	Rolls / linear ft	Rolls / linear m
5XT	± 0.36	± 1.19
10XT	± 0.31	± 1.02

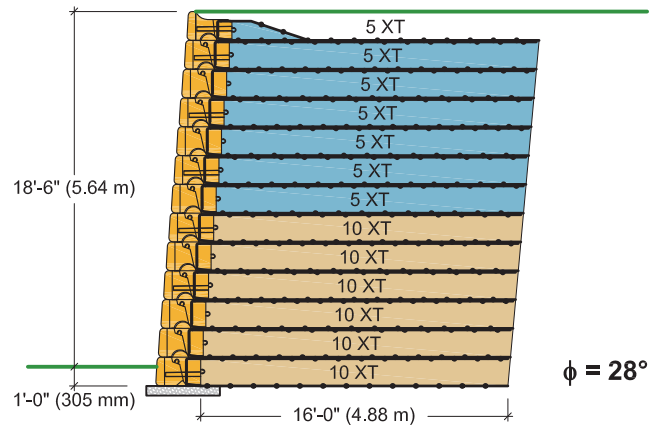

14 BLOCK SECTION  
(14) 28" (710 mm) Blocks

Geogrid Rolls Required per Wall Length		
Type	Rolls / linear ft	Rolls / linear m
5XT	± 0.36	± 1.19
10XT	± 0.36	± 1.19

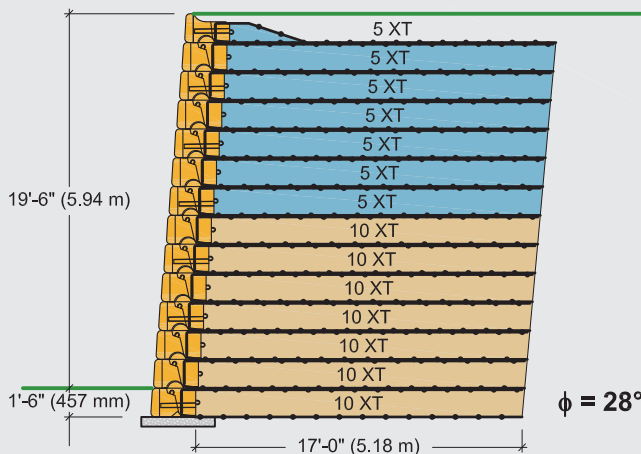

15 BLOCK SECTION  
(15) 28" (710 mm) Blocks

Geogrid Rolls Required per Wall Length		
Type	Rolls / linear ft	Rolls / linear m
5XT	± 0.36	± 1.19
10XT	± 0.36	± 1.19
20XT	± 0.05	± 0.17

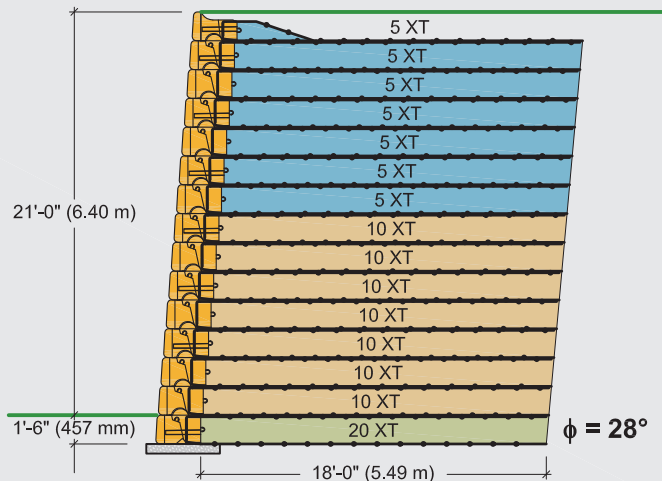

**Legend:**

= 28" (710mm) BLOCK

= 41" (1030 mm) BLOCK

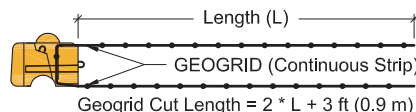

Geogrid shall be 12" (305 mm) wide strips of Mirafi geogrid, type as noted. Geogrid shall be **factory cut** and **certified** for width and strength by TenCate Mirafi.

**SEE NOTES AND RECOMMENDED DETAILS AT START OF PRELIM. REINFORCEMENT SCHEDULE.**

# Preliminary Reinforcement Schedule

$\phi = 28^\circ$  | SILTY SAND or CLAYEY SAND



**LOAD CONDITION A** | NO LIVE LOAD SURCHARGE, NO BACK SLOPE, NO TOE SLOPE

16 BLOCK SECTION  
(16) 28" (710 mm) Blocks

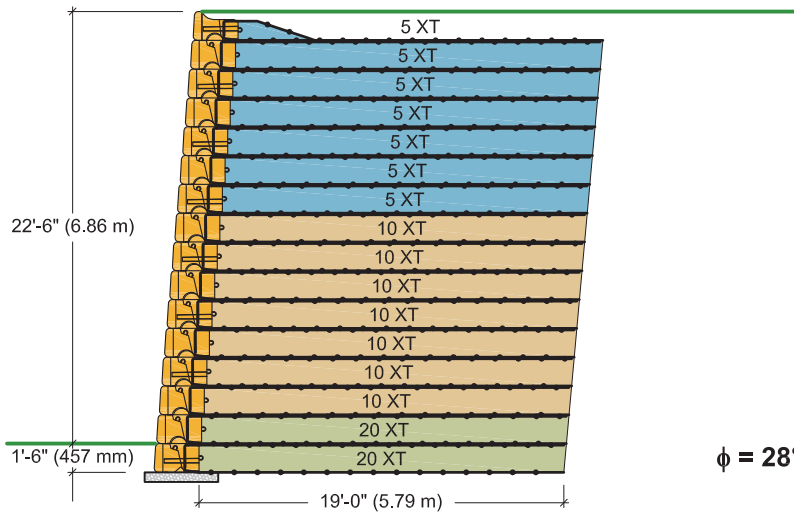
Geogrid Rolls Required per Wall Length		
Type	Rolls / linear ft	Rolls / linear m
5XT	± 0.46	± 1.49
10XT	± 0.46	± 1.49
20XT	± 0.13	± 0.43



**Legend:**

-  = 28" (710mm) BLOCK
-  = 41" (1030 mm) BLOCK

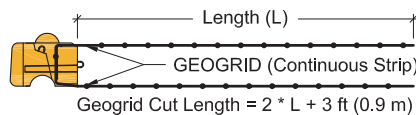

Geogrid shall be 12" (305 mm) wide strips of Mirafi geogrid, type as noted. Geogrid shall be **factory cut** and **certified** for width and strength by TenCate Mirafi.

**SEE NOTES AND RECOMMENDED DETAILS AT START OF PRELIM. REINFORCEMENT SCHEDULE.**

# Preliminary Reinforcement Schedule

$\phi = 28^\circ$  | SILTY SAND or CLAYEY SAND



**LOAD CONDITION A** | NO LIVE LOAD SURCHARGE, NO BACK SLOPE, NO TOE SLOPE

17 BLOCK SECTION  
(17) 28" (710 mm) Blocks

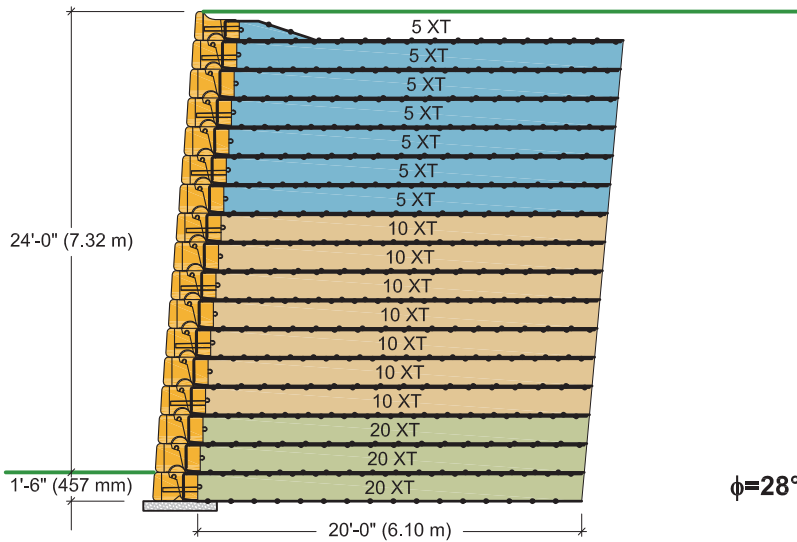
Geogrid Rolls Required per Wall Length		
Type	Rolls / linear ft	Rolls / linear m
5XT	± 0.46	± 1.49
10XT	± 0.46	± 1.49
20XT	± 0.20	± 0.64



**Legend:**

-  = 28" (710mm) BLOCK
-  = 41" (1030 mm) BLOCK

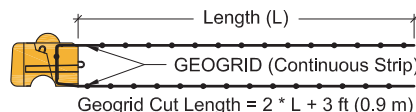

Geogrid shall be 12" (305 mm) wide strips of Mirafi geogrid, type as noted. Geogrid shall be **factory cut** and **certified** for width and strength by TenCate Mirafi.

**SEE NOTES AND RECOMMENDED DETAILS AT START OF PRELIM. REINFORCEMENT SCHEDULE.**

# Preliminary Reinforcement Schedule

$\phi = 28^\circ$  | SILTY SAND or CLAYEY SAND



**LOAD CONDITION A** | NO LIVE LOAD SURCHARGE, NO BACK SLOPE, NO TOE SLOPE

18 BLOCK SECTION  
(18) 28" (710 mm) Blocks

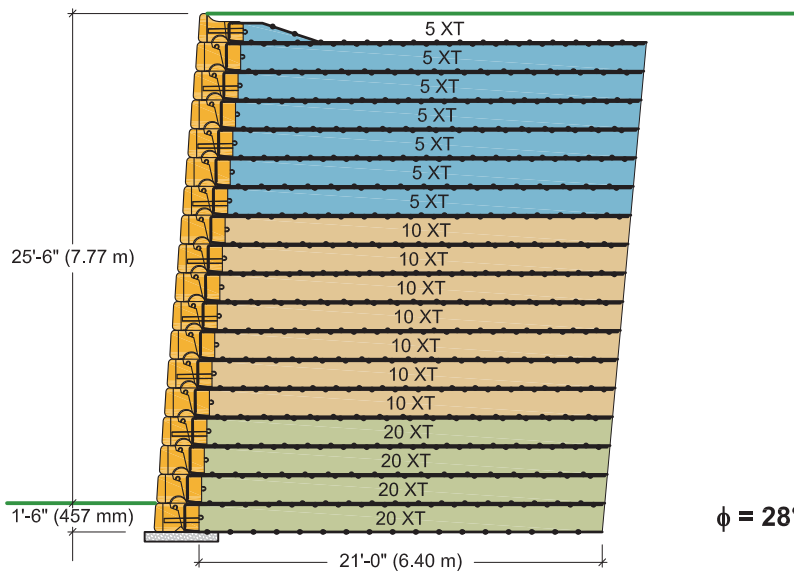
Geogrid Rolls Required per Wall Length		
Type	Rolls / linear ft	Rolls / linear m
5XT	± 0.46	± 1.49
10XT	± 0.46	± 1.49
20XT	± 0.26	± 0.85



**Legend:**

-  = 28" (710mm) BLOCK
-  = 41" (1030 mm) BLOCK

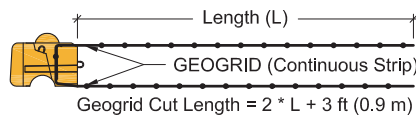

Geogrid shall be 12" (305 mm) wide strips of Mirafi geogrid, type as noted. Geogrid shall be **factory cut** and **certified** for width and strength by TenCate Mirafi.

**SEE NOTES AND RECOMMENDED DETAILS AT START OF PRELIM. REINFORCEMENT SCHEDULE.**

# Preliminary Reinforcement Schedule

$\phi = 28^\circ$  | SILTY SAND or CLAYEY SAND



**LOAD CONDITION A** | NO LIVE LOAD SURCHARGE, NO BACK SLOPE, NO TOE SLOPE

19 BLOCK SECTION  
(19) 28" (710 mm) Blocks

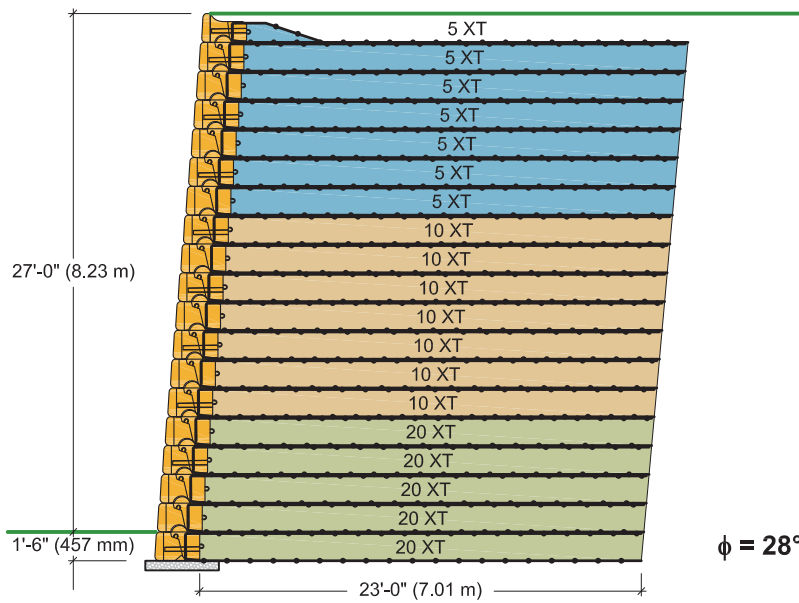
Geogrid Rolls Required per Wall Length		
Type	Rolls / linear ft	Rolls / linear m
5XT	± 0.46	± 1.49
10XT	± 0.46	± 1.49
20XT	± 0.33	± 1.07



**Legend:**

-  = 28" (710mm) BLOCK
-  = 41" (1030 mm) BLOCK

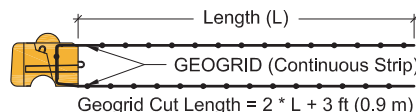

Geogrid shall be 12" (305 mm) wide strips of Mirafi geogrid, type as noted. Geogrid shall be **factory cut** and **certified** for width and strength by TenCate Mirafi.

**SEE NOTES AND RECOMMENDED DETAILS AT START OF PRELIM. REINFORCEMENT SCHEDULE.**

# Preliminary Reinforcement Schedule

$\phi = 28^\circ$  | SILTY SAND or CLAYEY SAND

**LOAD CONDITION A** | NO LIVE LOAD SURCHARGE, NO BACK SLOPE, NO TOE SLOPE

20 BLOCK SECTION \*  
(20) 28" (710 mm) Blocks

Type	Rolls / linear ft	Rolls / linear m
5XT	± 0.61	± 1.99
10XT	± 0.61	± 1.99
20XT	± 0.52	± 1.71

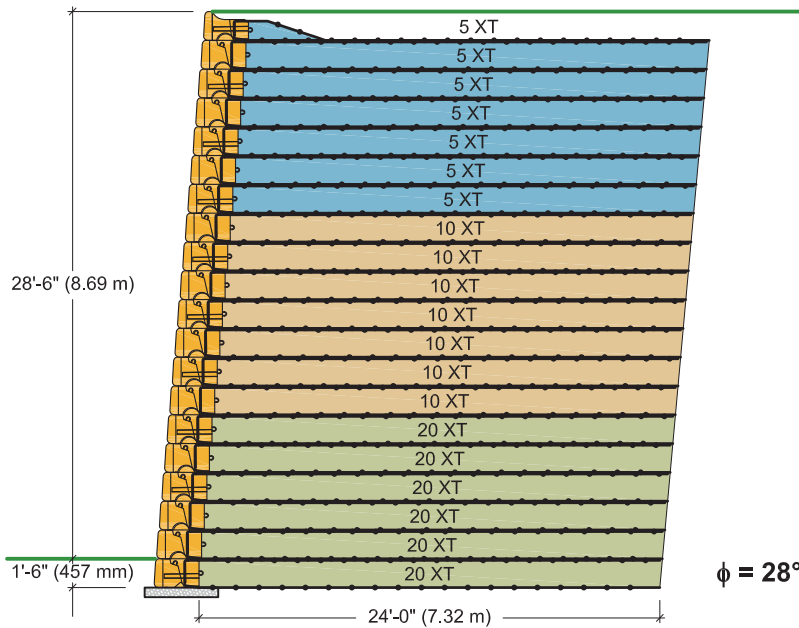

**Legend:**

= 28" (710mm) BLOCK

= 41" (1030 mm) BLOCK

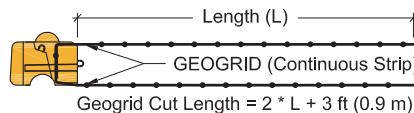

Geogrid shall be 12" (305 mm) wide strips of Mirafi geogrid, type as noted. Geogrid shall be **factory cut** and **certified** for width and strength by TenCate Mirafi.

**\* Not tall enough? You can build significantly taller walls with the Redi-Rock PC System...we just had to stop the preliminary sections somewhere. Talk to your Engineer or give us a call for more info.**

**SEE NOTES AND RECOMMENDED DETAILS AT START OF PRELIM. REINFORCEMENT SCHEDULE.**

# Preliminary Reinforcement Schedule

$\phi = 28^\circ$  | SILTY SAND or CLAYEY SAND

**LOAD CONDITION B** | 250 lb/ft<sup>2</sup> (12 kPa) LIVE LOAD SURCHARGE, NO BACK SLOPE, NO TOE SLOPE

**2 BLOCK SECTION**  
(2) 28" (710 mm) Blocks

Geogrid Rolls Required per Wall Length		
Type	Rolls / linear ft	Rolls / linear m
5XT	± 0.07	± 0.24

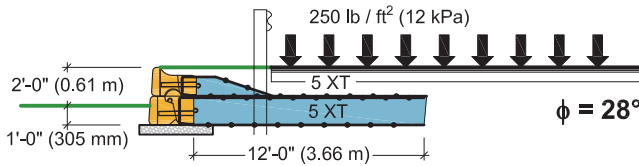

**3 BLOCK SECTION**  
(3) 28" (710 mm) Blocks

Geogrid Rolls Required per Wall Length		
Type	Rolls / linear ft	Rolls / linear m
5XT	± 0.11	± 0.37

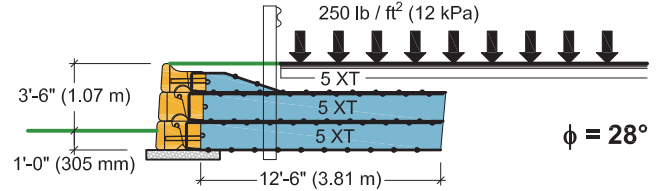

**4 BLOCK SECTION**  
(4) 28" (710 mm) Blocks

Geogrid Rolls Required per Wall Length		
Type	Rolls / linear ft	Rolls / linear m
5XT	± 0.17	± 0.57

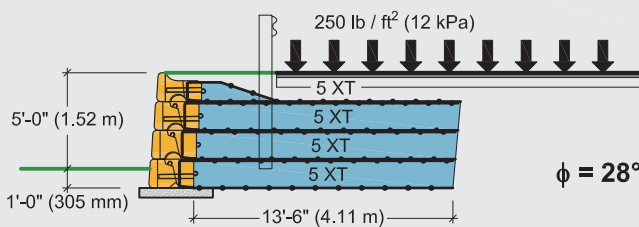

**5 BLOCK SECTION**  
(5) 28" (710 mm) Blocks

Geogrid Rolls Required per Wall Length		
Type	Rolls / linear ft	Rolls / linear m
5XT	± 0.22	± 0.71

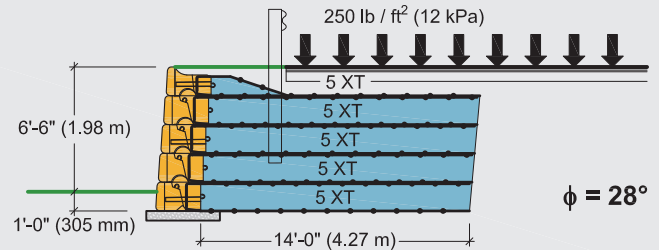

**6 BLOCK SECTION**  
(6) 28" (710 mm) Blocks

Geogrid Rolls Required per Wall Length		
Type	Rolls / linear ft	Rolls / linear m
5XT	± 0.22	± 0.71
8XT	± 0.04	± 0.14

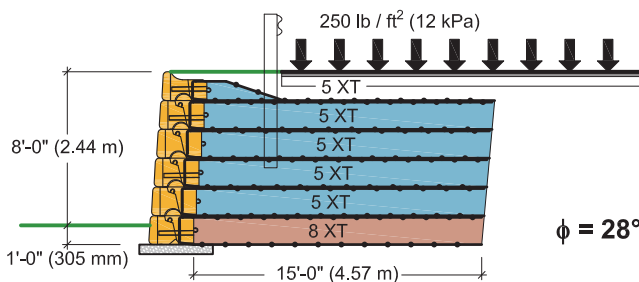

**7 BLOCK SECTION**  
(7) 28" (710 mm) Blocks

Geogrid Rolls Required per Wall Length		
Type	Rolls / linear ft	Rolls / linear m
5XT	± 0.26	± 0.85
8XT	± 0.10	± 0.34

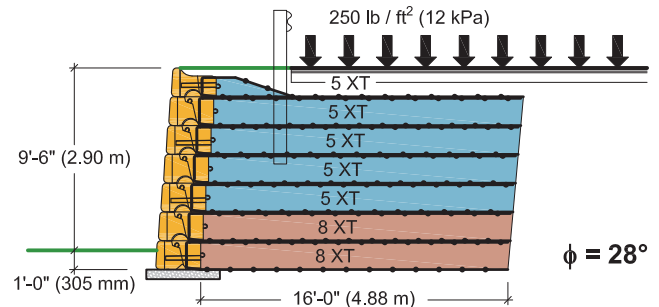

**Legend:**

= 28" (710mm) BLOCK

= 41" (1030 mm) BLOCK

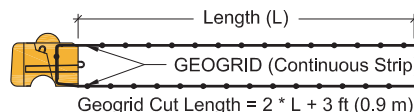

Geogrid shall be 12" (305 mm) wide strips of Mirafi geogrid, type as noted. Geogrid shall be **factory cut** and **certified** for width and strength by TenCate Mirafi.

**SEE NOTES AND RECOMMENDED DETAILS AT START OF PRELIM. REINFORCEMENT SCHEDULE.**

# Preliminary Reinforcement Schedule

$\phi = 28^\circ$  | SILTY SAND or CLAYEY SAND

**LOAD CONDITION B** | 250 lb/ft<sup>2</sup> (12 kPa) LIVE LOAD SURCHARGE, NO BACK SLOPE, NO TOE SLOPE

8 BLOCK SECTION  
(8) 28" (710 mm) Blocks

Geogrid Rolls Required per Wall Length		
Type	Rolls / linear ft	Rolls / linear m
5XT	± 0.26	± 0.85
8XT	± 0.16	± 0.51

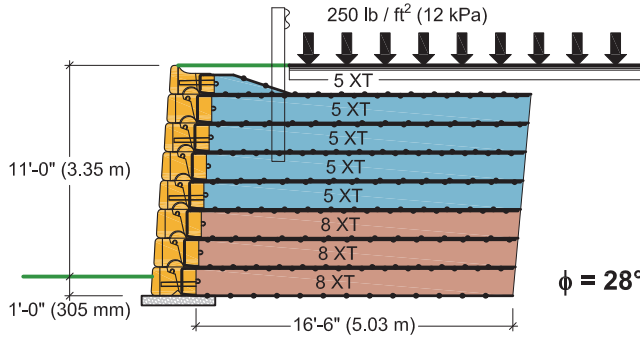

9 BLOCK SECTION  
(9) 28" (710 mm) Blocks

Geogrid Rolls Required per Wall Length		
Type	Rolls / linear ft	Rolls / linear m
5XT	± 0.26	± 0.85
8XT	± 0.21	± 0.68

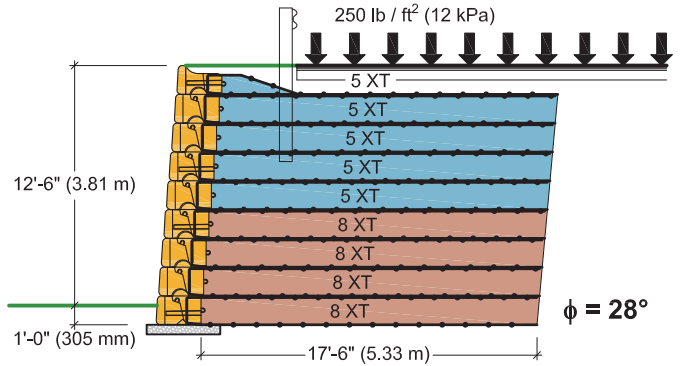

10 BLOCK SECTION  
(10) 28" (710 mm) Blocks

Geogrid Rolls Required per Wall Length		
Type	Rolls / linear ft	Rolls / linear m
5XT	± 0.26	± 0.85
8XT	± 0.26	± 0.85

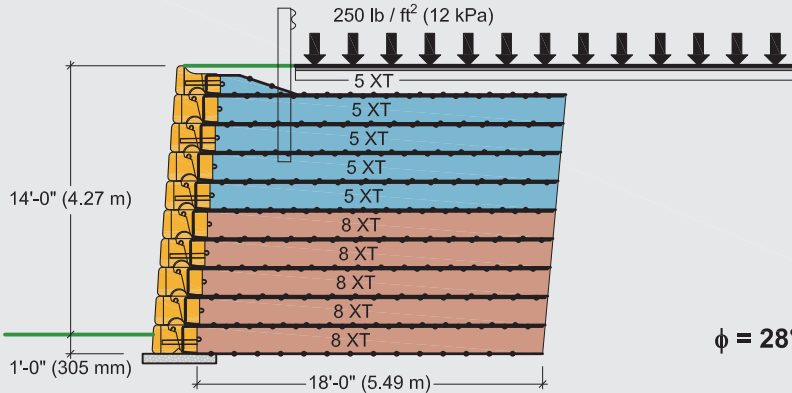

**Legend:**

= 28" (710mm) BLOCK

= 41" (1030 mm) BLOCK

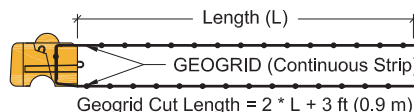

Geogrid shall be 12" (305 mm) wide strips of Mirafi geogrid, type as noted. Geogrid shall be **factory cut** and **certified** for width and strength by TenCate Mirafi.

**SEE NOTES AND RECOMMENDED DETAILS AT START OF PRELIM. REINFORCEMENT SCHEDULE.**

# Preliminary Reinforcement Schedule

$\phi = 28^\circ$  | SILTY SAND or CLAYEY SAND

**LOAD CONDITION B** | 250 lb/ft<sup>2</sup> (12 kPa) LIVE LOAD SURCHARGE, NO BACK SLOPE, NO TOE SLOPE

11 BLOCK SECTION  
(11) 28" (710 mm) Blocks

Geogrid Rolls Required per Wall Length		
Type	Rolls / linear ft	Rolls / linear m
5XT	± 0.33	± 1.07
10XT	± 0.39	± 1.28

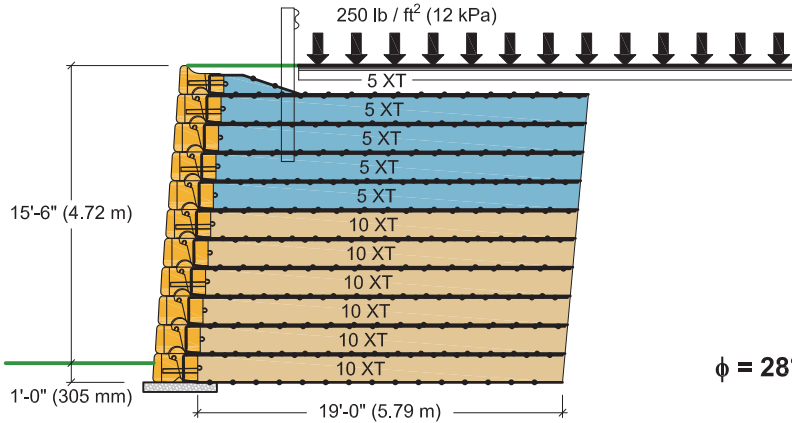

$\phi = 28^\circ$

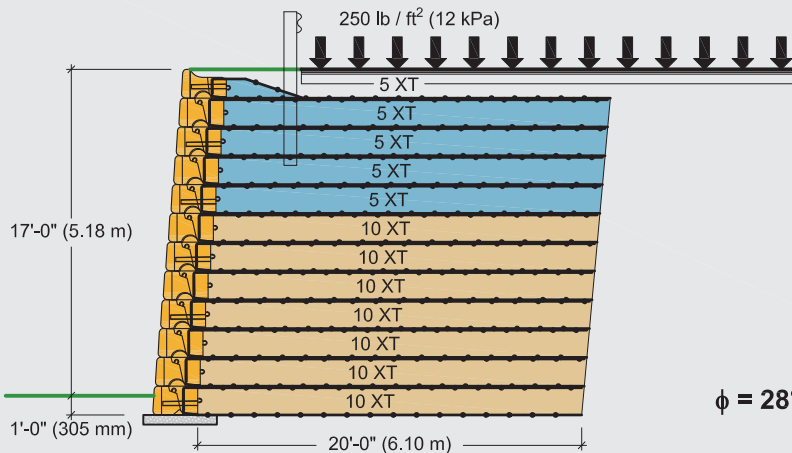

12 BLOCK SECTION  
(12) 28" (710 mm) Blocks

Geogrid Rolls Required per Wall Length		
Type	Rolls / linear ft	Rolls / linear m
5XT	± 0.33	± 1.07
10XT	± 0.46	± 1.49



$\phi = 28^\circ$

**Legend:**

-  = 28" (710mm) BLOCK
-  = 41" (1030 mm) BLOCK

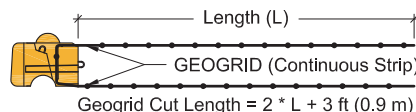

Geogrid shall be 12" (305 mm) wide strips of Mirafi geogrid, type as noted. Geogrid shall be **factory cut** and **certified** for width and strength by TenCate Mirafi.

**SEE NOTES AND RECOMMENDED DETAILS AT START OF PRELIM. REINFORCEMENT SCHEDULE.**

# Preliminary Reinforcement Schedule

$\phi = 28^\circ$  | SILTY SAND or CLAYEY SAND

**LOAD CONDITION B** | 250 lb/ft<sup>2</sup> (12 kPa) LIVE LOAD SURCHARGE, NO BACK SLOPE, NO TOE SLOPE

13 BLOCK SECTION  
(13) 28" (710 mm) Blocks

Geogrid Rolls Required per Wall Length		
Type	Rolls / linear ft	Rolls / linear m
5XT	± 0.33	± 1.07
10XT	± 0.52	± 1.71

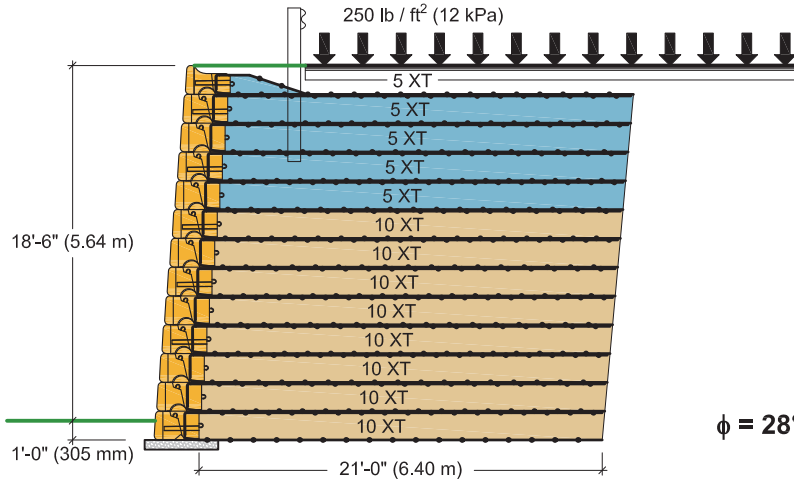

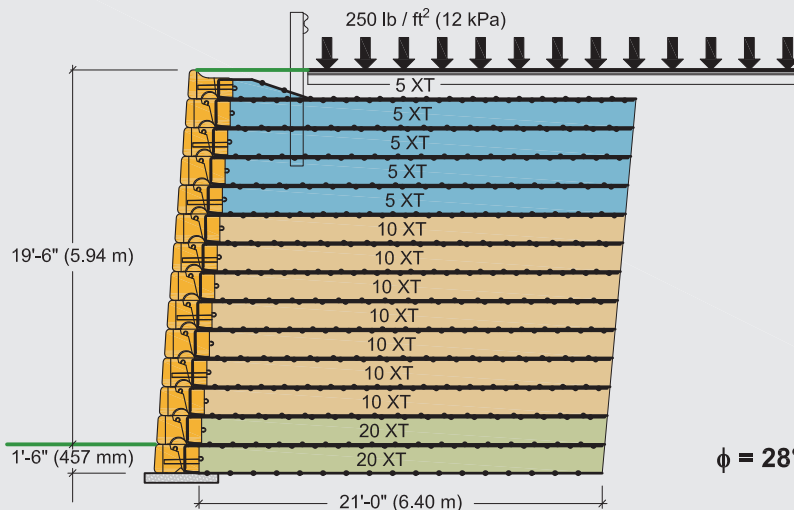

14 BLOCK SECTION  
(14) 28" (710 mm) Blocks

Geogrid Rolls Required per Wall Length		
Type	Rolls / linear ft	Rolls / linear m
5XT	± 0.33	± 1.07
10XT	± 0.46	± 1.49
20XT	± 0.13	± 0.43



**Legend:**

-  = 28" (710mm) BLOCK
-  = 41" (1030 mm) BLOCK

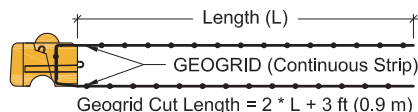

Geogrid shall be 12" (305 mm) wide strips of Mirafi geogrid, type as noted. Geogrid shall be **factory cut** and **certified** for width and strength by TenCate Mirafi.

**SEE NOTES AND RECOMMENDED DETAILS AT START OF PRELIM. REINFORCEMENT SCHEDULE.**

# Preliminary Reinforcement Schedule

$\phi = 28^\circ$  | SILTY SAND or CLAYEY SAND



**LOAD CONDITION B** | 250 lb/ft<sup>2</sup> (12 kPa) LIVE LOAD SURCHARGE, NO BACK SLOPE, NO TOE SLOPE

15 BLOCK SECTION  
(15) 28" (710 mm) Blocks

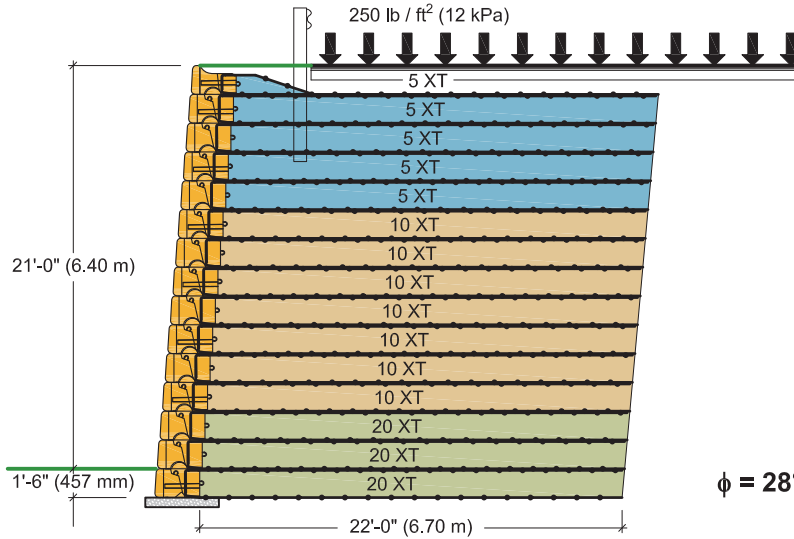
Geogrid Rolls Required per Wall Length		
Type	Rolls / linear ft	Rolls / linear m
5XT	± 0.33	± 1.07
10XT	± 0.46	± 1.49
20XT	± 0.20	± 0.64



**Legend:**

-  = 28" (710mm) BLOCK
-  = 41" (1030 mm) BLOCK

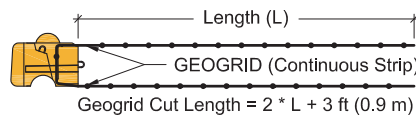

Geogrid shall be 12" (305 mm) wide strips of Mirafi geogrid, type as noted. Geogrid shall be **factory cut** and **certified** for width and strength by TenCate Mirafi.

**SEE NOTES AND RECOMMENDED DETAILS AT START OF PRELIM. REINFORCEMENT SCHEDULE.**

# Preliminary Reinforcement Schedule

$\phi = 28^\circ$  | SILTY SAND or CLAYEY SAND



**LOAD CONDITION B** | 250 lb/ft<sup>2</sup> (12 kPa) LIVE LOAD SURCHARGE, NO BACK SLOPE, NO TOE SLOPE

16 BLOCK SECTION  
(16) 28" (710 mm) Blocks

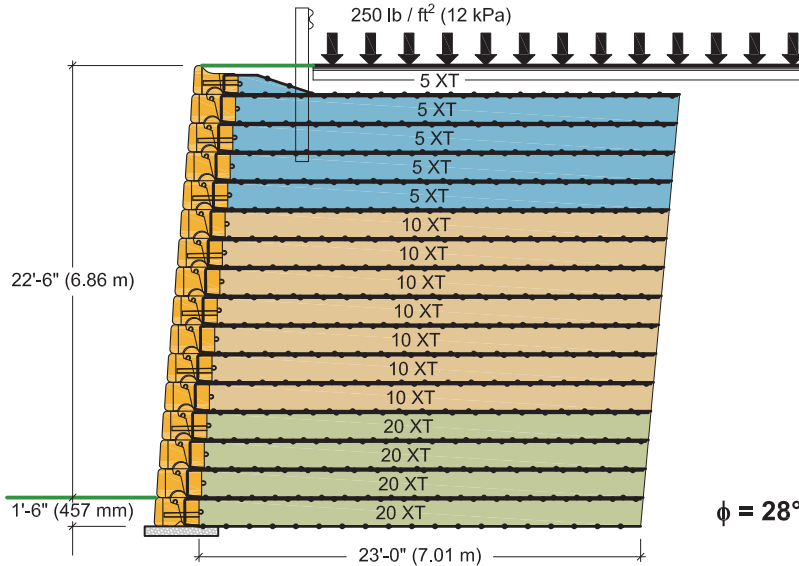
Geogrid Rolls Required per Wall Length		
Type	Rolls / linear ft	Rolls / linear m
5XT	± 0.33	± 1.07
10XT	± 0.46	± 1.49
20XT	± 0.26	± 0.85



**Legend:**

-  = 28" (710mm) BLOCK
-  = 41" (1030 mm) BLOCK

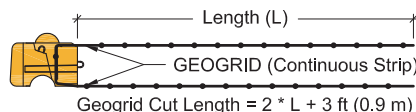

Geogrid shall be 12" (305 mm) wide strips of Mirafi geogrid, type as noted. Geogrid shall be **factory cut** and **certified** for width and strength by TenCate Mirafi.

**SEE NOTES AND RECOMMENDED DETAILS AT START OF PRELIM. REINFORCEMENT SCHEDULE.**

# Preliminary Reinforcement Schedule

$\phi = 28^\circ$  | SILTY SAND or CLAYEY SAND



**LOAD CONDITION B** | 250 lb/ft<sup>2</sup> (12 kPa) LIVE LOAD SURCHARGE, NO BACK SLOPE, NO TOE SLOPE

17 BLOCK SECTION  
(17) 28" (710 mm) Blocks

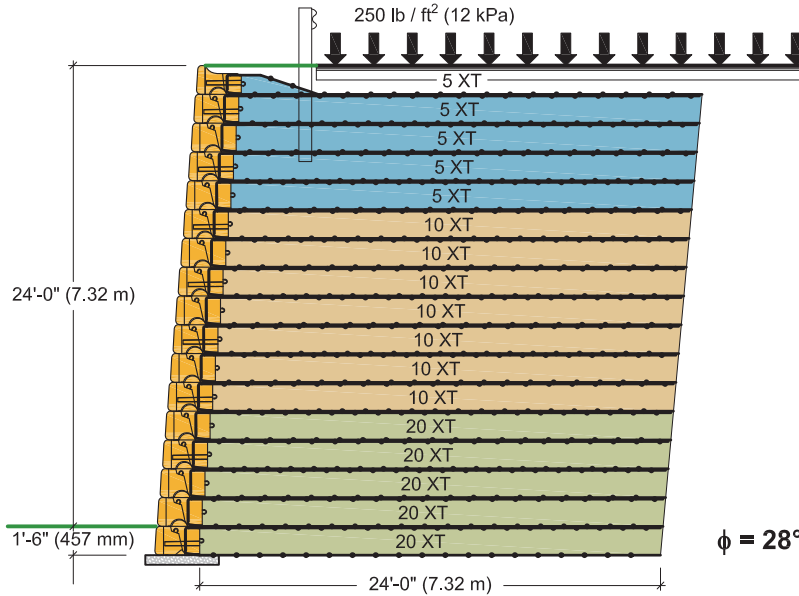
Geogrid Rolls Required per Wall Length		
Type	Rolls / linear ft	Rolls / linear m
5XT	± 0.43	± 1.42
10XT	± 0.61	± 1.99
20XT	± 0.43	± 1.42



**Legend:**

-  = 28" (710mm) BLOCK
-  = 41" (1030 mm) BLOCK

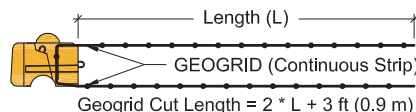

Geogrid shall be 12" (305 mm) wide strips of Mirafi geogrid, type as noted. Geogrid shall be **factory cut** and **certified** for width and strength by TenCate Mirafi.

**SEE NOTES AND RECOMMENDED DETAILS AT START OF PRELIM. REINFORCEMENT SCHEDULE.**

# Preliminary Reinforcement Schedule

$\phi = 28^\circ$  | SILTY SAND or CLAYEY SAND

**LOAD CONDITION B** | 250 lb/ft<sup>2</sup> (12 kPa) LIVE LOAD SURCHARGE, NO BACK SLOPE, NO TOE SLOPE

18 BLOCK SECTION  
(18) 28" (710 mm) Blocks

Geogrid Rolls Required per Wall Length		
Type	Rolls / linear ft	Rolls / linear m
5XT	± 0.43	± 1.42
10XT	± 0.61	± 1.99
20XT	± 0.52	± 1.71

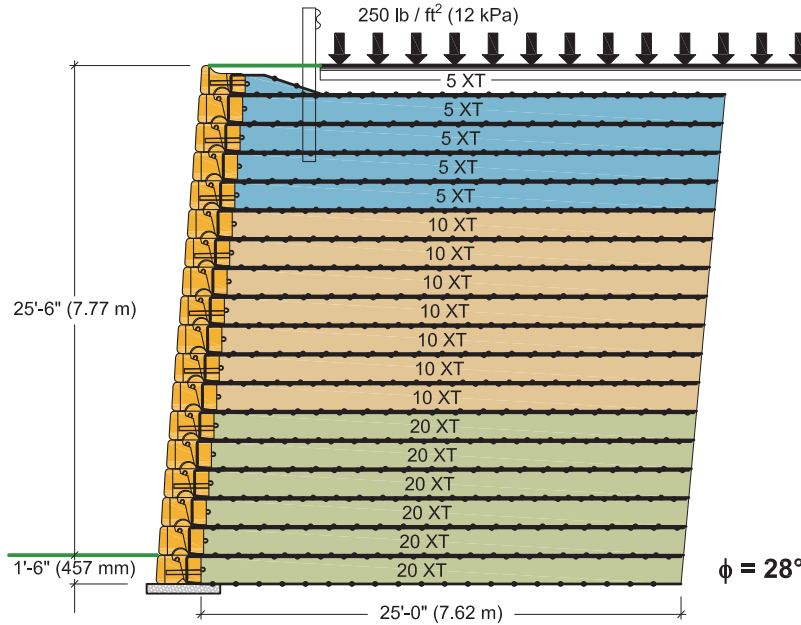

**Legend:**

- = 28" (710mm) BLOCK
- = 41" (1030 mm) BLOCK

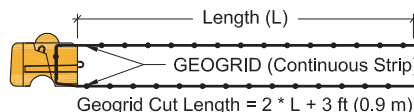

Geogrid shall be 12" (305 mm) wide strips of Mirafi geogrid, type as noted. Geogrid shall be **factory cut** and **certified** for width and strength by TenCate Mirafi.

**SEE NOTES AND RECOMMENDED DETAILS AT START OF PRELIM. REINFORCEMENT SCHEDULE.**

# Preliminary Reinforcement Schedule

$\phi = 28^\circ$  | SILTY SAND or CLAYEY SAND

**LOAD CONDITION B** | 250 lb/ft<sup>2</sup> (12 kPa) LIVE LOAD SURCHARGE, NO BACK SLOPE, NO TOE SLOPE

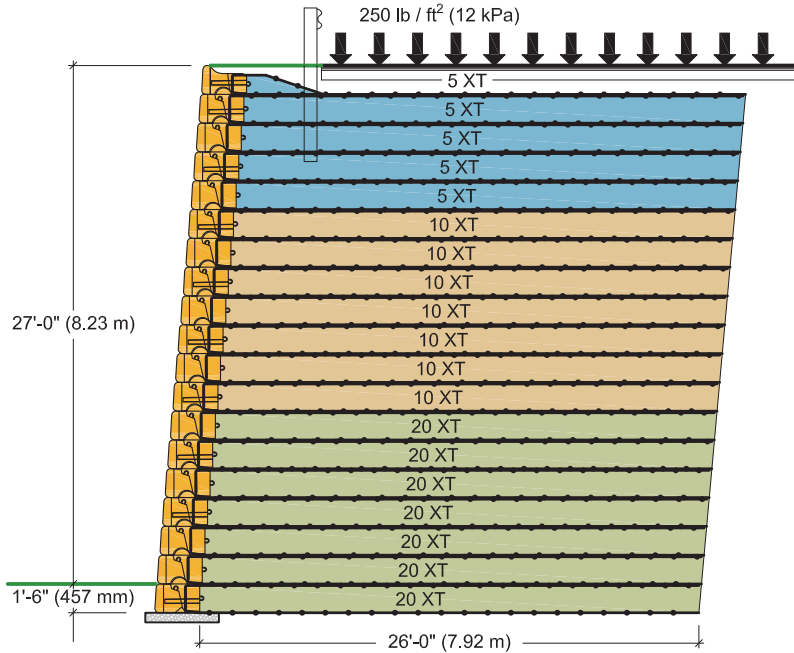

19 BLOCK SECTION  
(19) 28" (710 mm) Blocks

Geogrid Rolls Required per Wall Length		
Type	Rolls / linear ft	Rolls / linear m
5XT	± 0.43	± 1.42
10XT	± 0.61	± 1.99
20XT	± 0.61	± 1.99



$\phi = 28^\circ$

**Legend:**

-  = 28" (710mm) BLOCK
-  = 41" (1030 mm) BLOCK

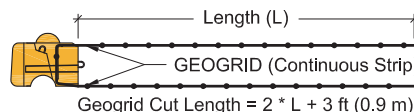

Geogrid shall be 12" (305 mm) wide strips of Mirafi geogrid, type as noted. Geogrid shall be **factory cut** and **certified** for width and strength by TenCate Mirafi.

**SEE NOTES AND RECOMMENDED DETAILS AT START OF PRELIM. REINFORCEMENT SCHEDULE.**

# Preliminary Reinforcement Schedule

$\phi = 28^\circ$  | SILTY SAND or CLAYEY SAND

**LOAD CONDITION B** | 250 lb/ft<sup>2</sup> (12 kPa) LIVE LOAD SURCHARGE, NO BACK SLOPE, NO TOE SLOPE

20 BLOCK SECTION \*  
(20) 28" (710 mm) Blocks

Geogrid Rolls Required per Wall Length		
Type	Rolls / linear ft	Rolls / linear m
5XT	± 0.43	± 1.42
10XT	± 0.61	± 1.99
20XT	± 0.52	± 1.71
24XT	± 0.17	± 0.57

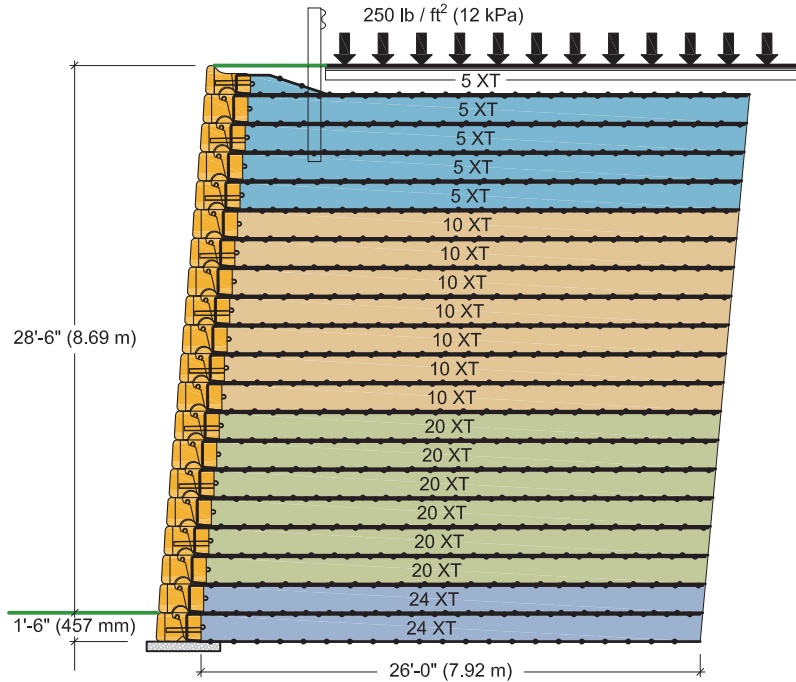

$\phi = 28^\circ$

**Legend:**

= 28" (710mm) BLOCK

= 41" (1030 mm) BLOCK

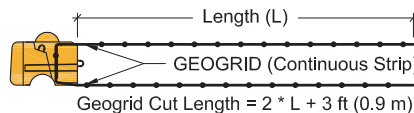

Geogrid shall be 12" (305 mm) wide strips of Mirafi geogrid, type as noted. Geogrid shall be **factory cut** and **certified** for width and strength by TenCate Mirafi.

**\* Not tall enough? You can build significantly taller walls with the Redi-Rock PC System...we just had to stop the preliminary sections somewhere. Talk to your Engineer or give us a call for more info.**

**SEE NOTES AND RECOMMENDED DETAILS AT START OF PRELIM. REINFORCEMENT SCHEDULE.**

# Preliminary Reinforcement Schedule

$\phi = 28^\circ$  | SILTY SAND or CLAYEY SAND

**LOAD CONDITION CR** | 1 : 2 CREST SLOPE, 10' (3.0 m) HIGH, 250 lb/ft<sup>2</sup> (12 kPa) SURCHARGE AT CREST, NO TOE SLOPE

2 BLOCK HIGH SECTION  
(2) 28" (710 mm) Blocks

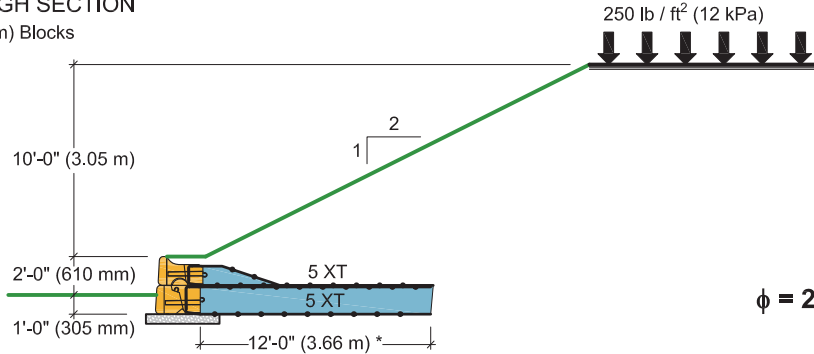

Geogrid Rolls Required per Wall Length		
Type	Rolls / linear ft	Rolls / linear m
5XT	± 0.07	± 0.24

3 BLOCK HIGH SECTION  
(3) 28" (710 mm) Blocks

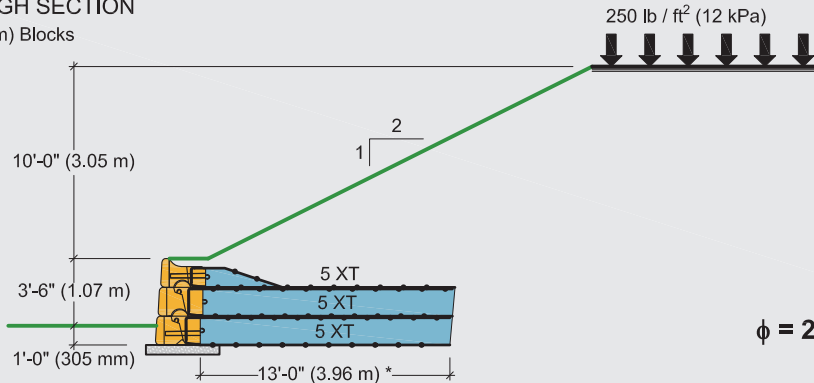

Geogrid Rolls Required per Wall Length		
Type	Rolls / linear ft	Rolls / linear m
5XT	± 0.13	± 0.43

4 BLOCK HIGH SECTION  
(4) 28" (710 mm) Blocks

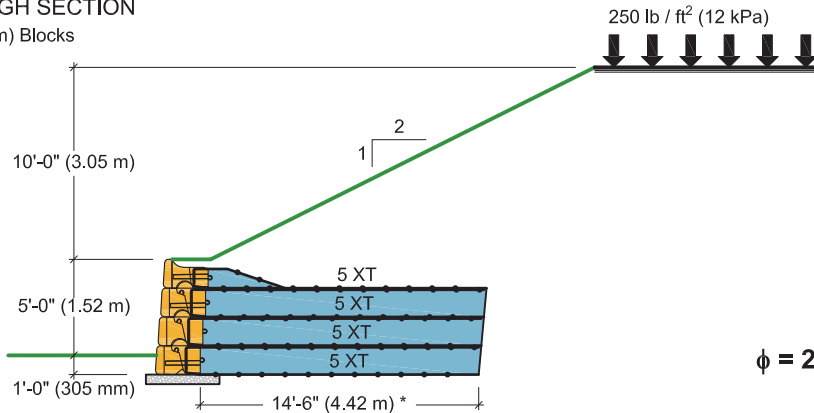

Geogrid Rolls Required per Wall Length		
Type	Rolls / linear ft	Rolls / linear m
5XT	± 0.17	± 0.57

**Legend:**

= 28" (710mm) BLOCK

= 41" (1030 mm) BLOCK

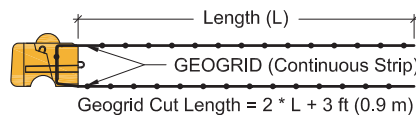

Geogrid shall be 12" (305 mm) wide strips of Mirafi geogrid, type as noted. Geogrid shall be **factory cut** and **certified** for width and strength by TenCate Mirafi.

\* Geogrid length primarily controlled by global stability. Length will change with crest height.

**SEE NOTES AND RECOMMENDED DETAILS AT START OF PRELIM. REINFORCEMENT SCHEDULE.**

# Preliminary Reinforcement Schedule

$\phi = 28^\circ$  | SILTY SAND or CLAYEY SAND

**LOAD CONDITION CR** | 1 : 2 CREST SLOPE, 10' (3.0 m) HIGH, 250 lb/ft<sup>2</sup> (12 kPa) SURCHARGE AT CREST, NO TOE SLOPE

5 BLOCK HIGH SECTION  
(5) 28" (710 mm) Blocks

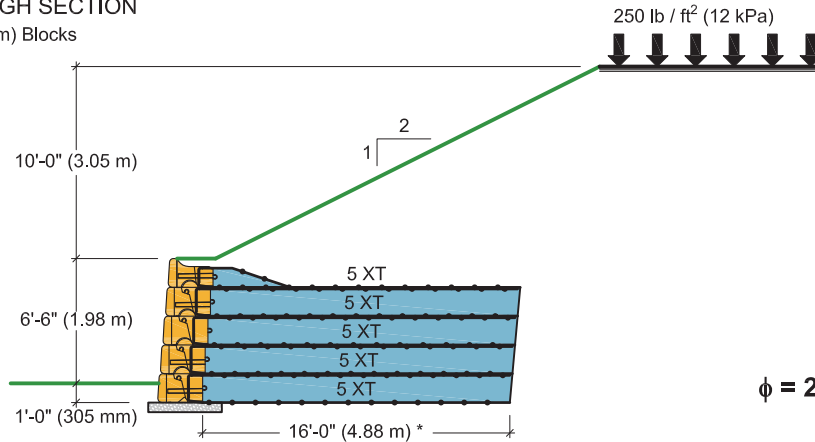

Geogrid Rolls Required per Wall Length		
Type	Rolls / linear ft	Rolls / linear m
5XT	± 0.26	± 0.85

$\phi = 28^\circ$

6 BLOCK HIGH SECTION  
(6) 28" (710 mm) Blocks

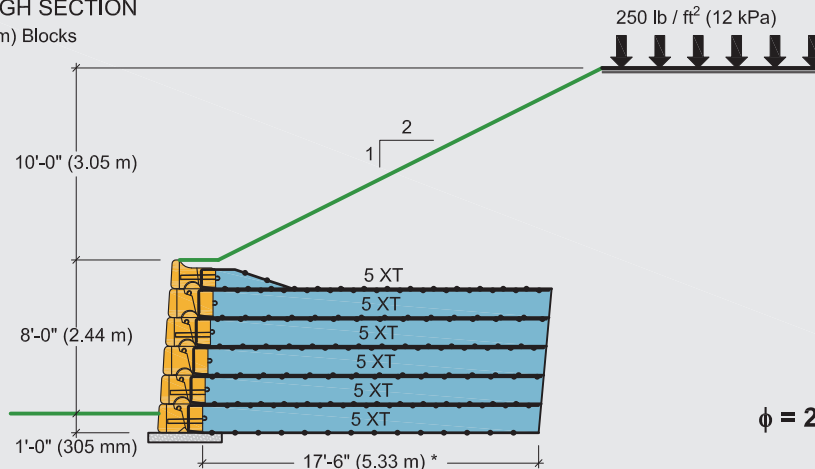

Geogrid Rolls Required per Wall Length		
Type	Rolls / linear ft	Rolls / linear m
5XT	± 0.31	± 1.02

$\phi = 28^\circ$

**Legend:**

= 28" (710mm) BLOCK

= 41" (1030 mm) BLOCK

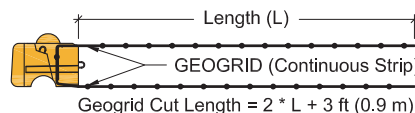

Geogrid shall be 12" (305 mm) wide strips of Mirafi geogrid, type as noted. Geogrid shall be **factory cut** and **certified** for width and strength by TenCate Mirafi.

**\* Geogrid length primarily controlled by global stability. Length will change with crest height.**

**SEE NOTES AND RECOMMENDED DETAILS AT START OF PRELIM. REINFORCEMENT SCHEDULE.**

# Preliminary Reinforcement Schedule

$\phi = 28^\circ$  | SILTY SAND or CLAYEY SAND

**LOAD CONDITION CR** | 1 : 2 CREST SLOPE, 10' (3.0 m) HIGH, 250 lb/ft<sup>2</sup> (12 kPa) SURCHARGE AT CREST, NO TOE SLOPE

7 BLOCK HIGH SECTION  
(7) 28" (710 mm) Blocks

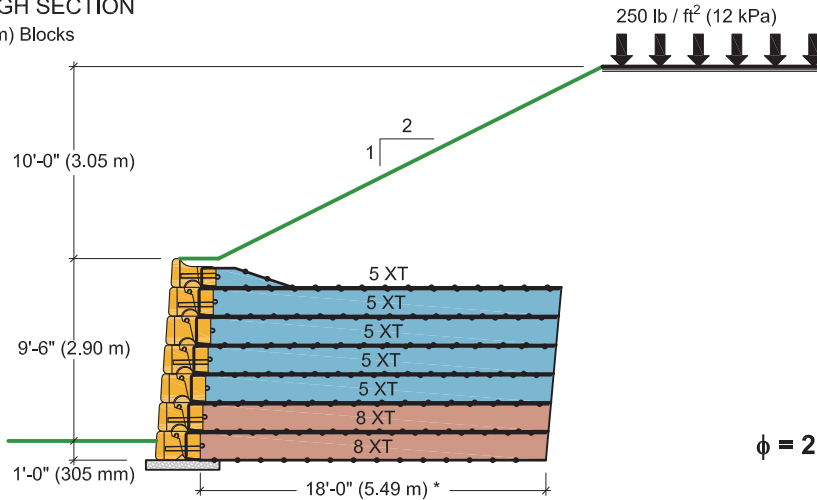

Geogrid Rolls Required per Wall Length		
Type	Rolls / linear ft	Rolls / linear m
5XT	± 0.26	± 0.85
8XT	± 0.10	± 0.34

$\phi = 28^\circ$

8 BLOCK HIGH SECTION  
(8) 28" (710 mm) Blocks

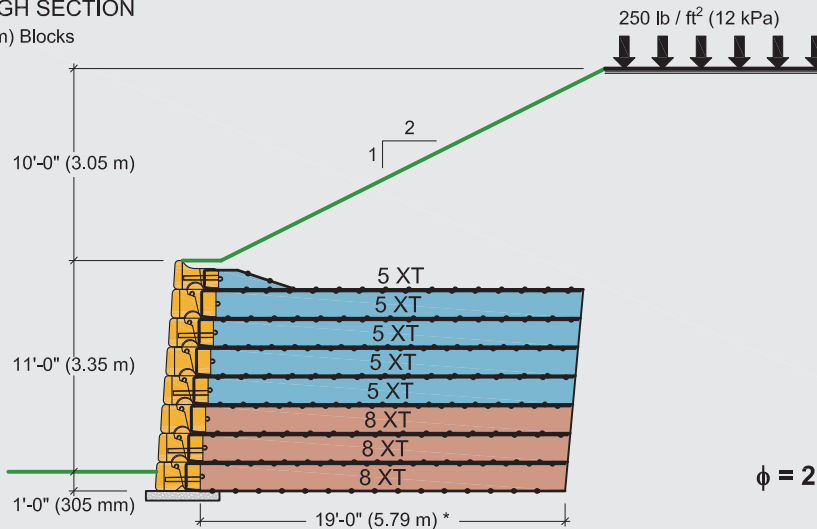

Geogrid Rolls Required per Wall Length		
Type	Rolls / linear ft	Rolls / linear m
5XT	± 0.33	± 1.07
8XT	± 0.20	± 0.64

$\phi = 28^\circ$

**Legend:**

= 28" (710mm) BLOCK

= 41" (1030 mm) BLOCK

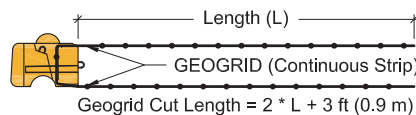

Geogrid shall be 12" (305 mm) wide strips of Mirafi geogrid, type as noted. Geogrid shall be **factory cut** and **certified** for width and strength by TenCate Mirafi.

\* Geogrid length primarily controlled by global stability. Length will change with crest height.

**SEE NOTES AND RECOMMENDED DETAILS AT START OF PRELIM. REINFORCEMENT SCHEDULE.**

# Preliminary Reinforcement Schedule

$\phi = 28^\circ$  | SILTY SAND or CLAYEY SAND

**LOAD CONDITION CR** | 1 : 2 CREST SLOPE, 10' (3.0 m) HIGH, 250 lb/ft<sup>2</sup> (12 kPa) SURCHARGE AT CREST, NO TOE SLOPE

9 BLOCK HIGH SECTION  
(9) 28" (710 mm) Blocks

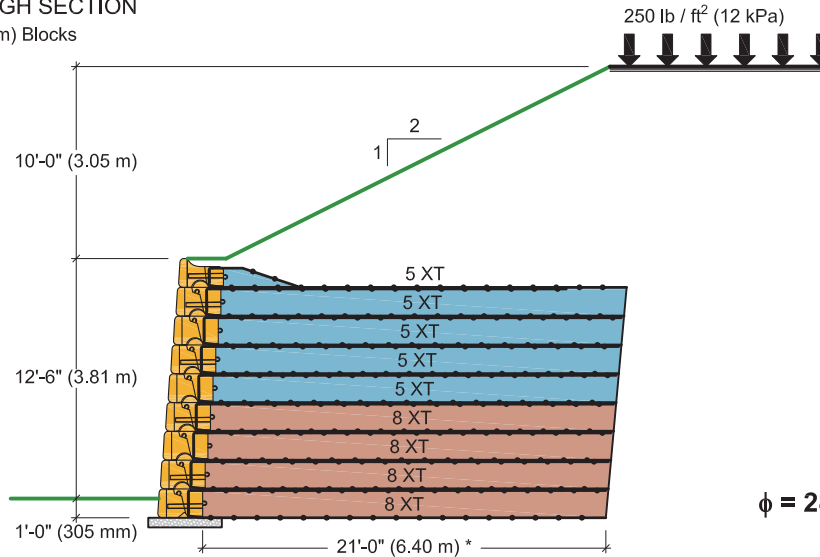

Geogrid Rolls Required per Wall Length		
Type	Rolls / linear ft	Rolls / linear m
5XT	± 0.33	± 1.07
8XT	± 0.26	± 0.85

$\phi = 28^\circ$

10 BLOCK HIGH SECTION  
(10) 28" (710 mm) Blocks

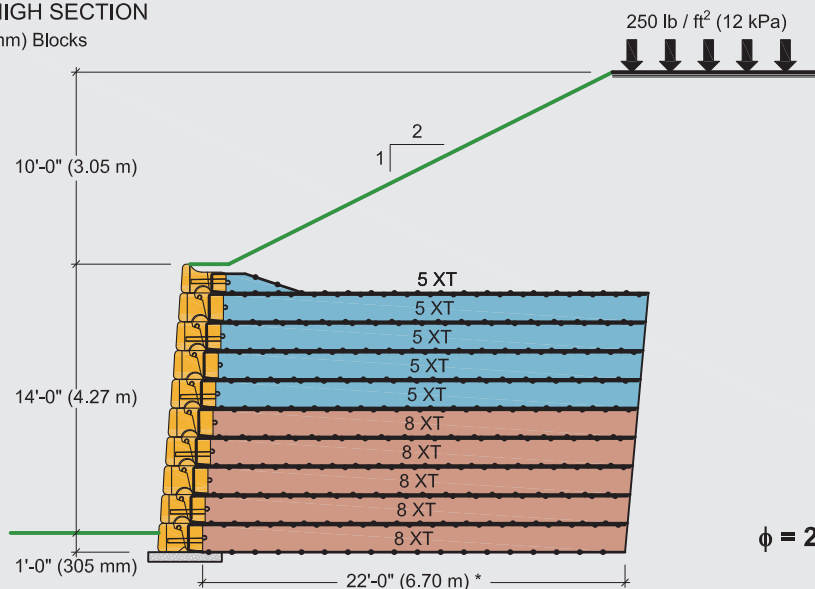

Geogrid Rolls Required per Wall Length		
Type	Rolls / linear ft	Rolls / linear m
5XT	± 0.33	± 1.07
8XT	± 0.33	± 1.07

$\phi = 28^\circ$

**Legend:**

= 28" (710mm) BLOCK

= 41" (1030 mm) BLOCK

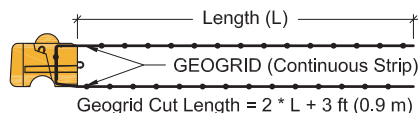

Geogrid shall be 12" (305 mm) wide strips of Mirafi geogrid, type as noted. Geogrid shall be **factory cut** and **certified** for width and strength by TenCate Mirafi.

\* Geogrid length primarily controlled by global stability. Length will change with crest height.

**SEE NOTES AND RECOMMENDED DETAILS AT START OF PRELIM. REINFORCEMENT SCHEDULE.**

# Preliminary Reinforcement Schedule

$\phi = 28^\circ$  | SILTY SAND or CLAYEY SAND

**LOAD CONDITION CR** | 1 : 2 CREST SLOPE, 10' (3.0 m) HIGH, 250 lb/ft<sup>2</sup> (12 kPa) SURCHARGE AT CREST, NO TOE SLOPE

11 BLOCK HIGH SECTION  
(11) 28" (710 mm) Blocks

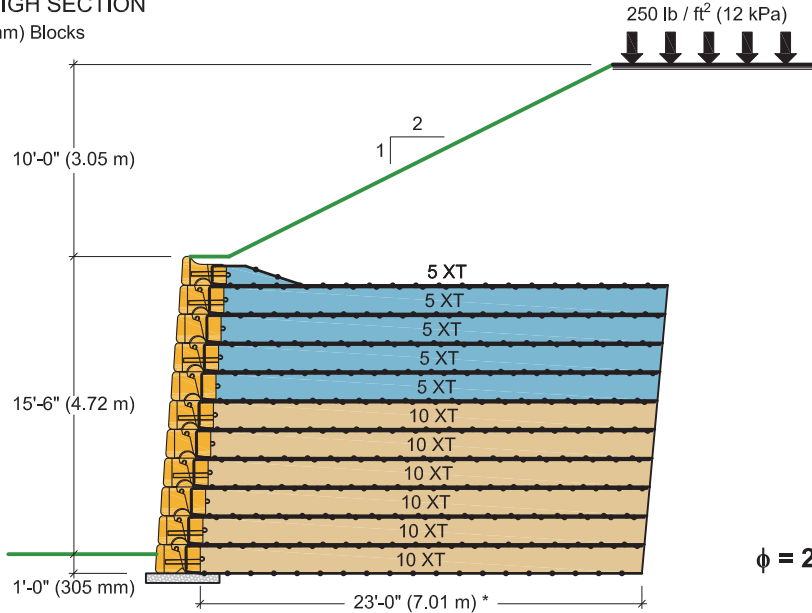

Geogrid Rolls Required per Wall Length		
Type	Rolls / linear ft	Rolls / linear m
5XT	± 0.33	± 1.07
10XT	± 0.39	± 1.28

12 BLOCK HIGH SECTION  
(12) 28" (710 mm) Blocks

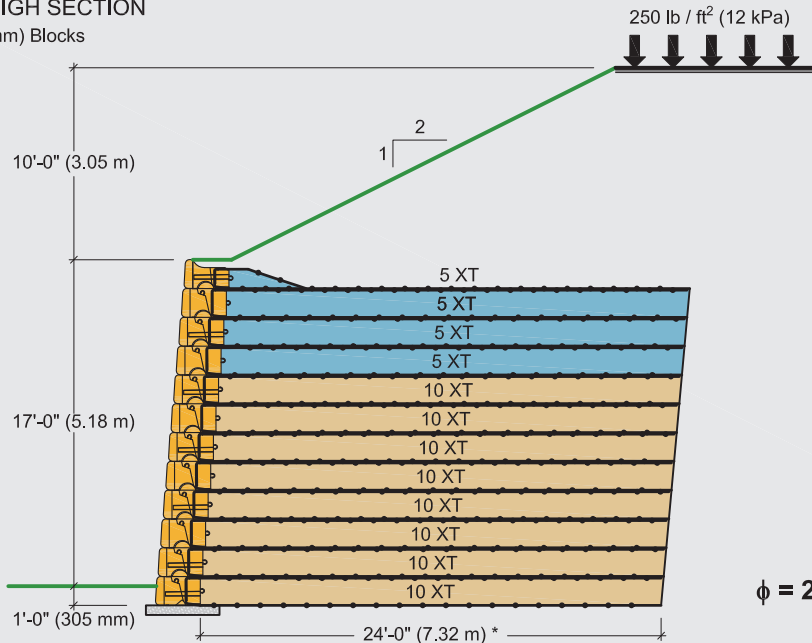

Geogrid Rolls Required per Wall Length		
Type	Rolls / linear ft	Rolls / linear m
5XT	± 0.35	± 1.14
10XT	± 0.69	± 2.28

**Legend:**

= 28" (710mm) BLOCK

= 41" (1030 mm) BLOCK

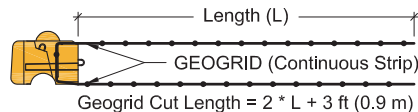

Geogrid shall be 12" (305 mm) wide strips of Mirafi geogrid, type as noted. Geogrid shall be **factory cut** and **certified** for width and strength by TenCate Mirafi.

\* **Geogrid length primarily controlled by global stability. Length will change with crest height.**

**SEE NOTES AND RECOMMENDED DETAILS AT START OF PRELIM. REINFORCEMENT SCHEDULE.**

# Preliminary Reinforcement Schedule

$\phi = 28^\circ$  | SILTY SAND or CLAYEY SAND

**LOAD CONDITION CR** | 1 : 2 CREST SLOPE, 10' (3.0 m) HIGH, 250 lb/ft<sup>2</sup> (12 kPa) SURCHARGE AT CREST, NO TOE SLOPE

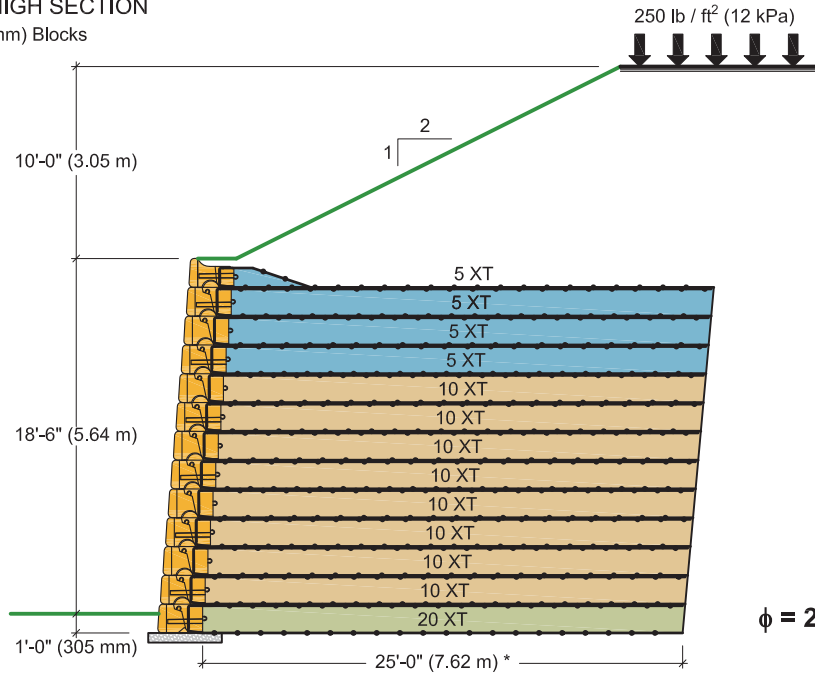

13 BLOCK HIGH SECTION  
(13) 28" (710 mm) Blocks



Geogrid Rolls Required per Wall Length		
Type	Rolls / linear ft	Rolls / linear m
5XT	± 0.35	± 1.14
10XT	± 0.69	± 2.28
20XT	± 0.09	± 0.28

$\phi = 28^\circ$

**Legend:**

-  = 28" (710mm) BLOCK
-  = 41" (1030 mm) BLOCK

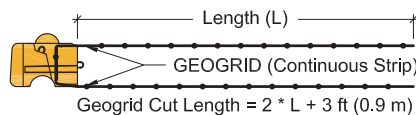

Geogrid shall be 12" (305 mm) wide strips of Mirafi geogrid, type as noted. Geogrid shall be **factory cut** and **certified** for width and strength by TenCate Mirafi.

**\* Geogrid length primarily controlled by global stability. Length will change with crest height.**

**SEE NOTES AND RECOMMENDED DETAILS AT START OF PRELIM. REINFORCEMENT SCHEDULE.**

# Preliminary Reinforcement Schedule

$\phi = 28^\circ$  | SILTY SAND or CLAYEY SAND

**LOAD CONDITION CR** | 1 : 2 CREST SLOPE, 10' (3.0 m) HIGH, 250 lb/ft<sup>2</sup> (12 kPa) SURCHARGE AT CREST, NO TOE SLOPE

14 BLOCK HIGH SECTION  
(14) 28" (710 mm) Blocks

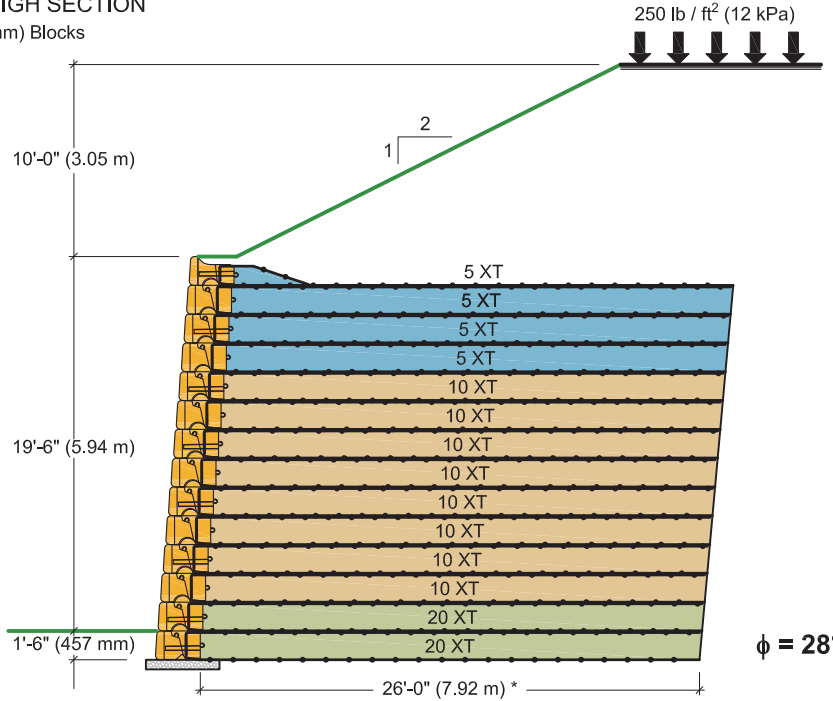

Geogrid Rolls Required per Wall Length		
Type	Rolls / linear ft	Rolls / linear m
5XT	± 0.35	± 1.14
10XT	± 0.69	± 2.28
20XT	± 0.17	± 0.57

$\phi = 28^\circ$

**Legend:**

- = 28" (710mm) BLOCK
- = 41" (1030 mm) BLOCK

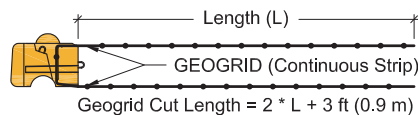

Geogrid shall be 12" (305 mm) wide strips of Mirafi geogrid, type as noted. Geogrid shall be **factory cut** and **certified** for width and strength by TenCate Mirafi.

**\* Geogrid length primarily controlled by global stability. Length will change with crest height.**

**SEE NOTES AND RECOMMENDED DETAILS AT START OF PRELIM. REINFORCEMENT SCHEDULE.**

# Preliminary Reinforcement Schedule

$\phi = 28^\circ$  | SILTY SAND or CLAYEY SAND

**LOAD CONDITION CR** | 1 : 2 CREST SLOPE, 10' (3.0 m) HIGH, 250 lb/ft<sup>2</sup> (12 kPa) SURCHARGE AT CREST, NO TOE SLOPE

15 BLOCK HIGH SECTION  
(15) 28" (710 mm) Blocks

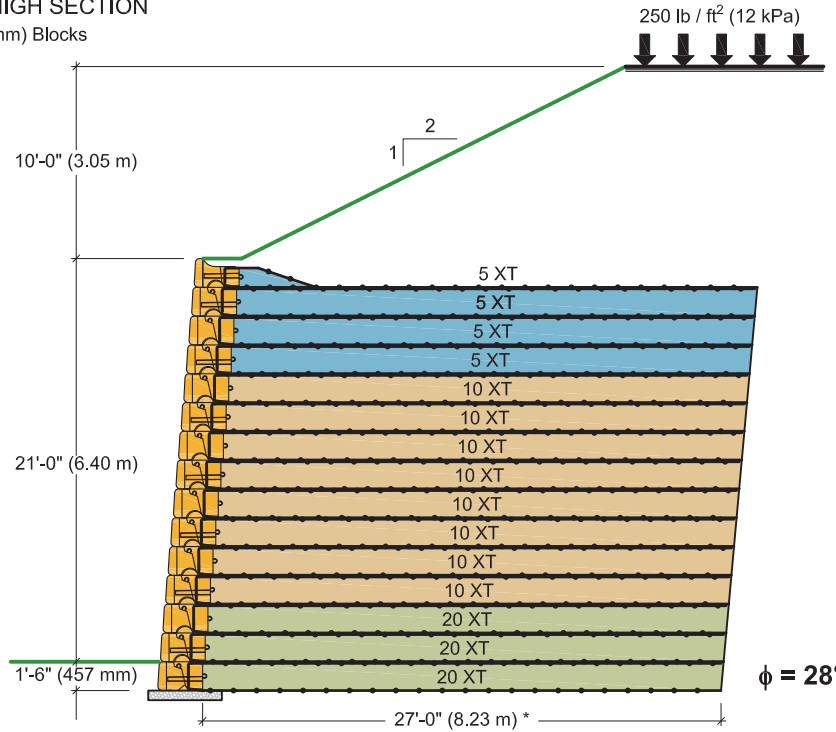

Geogrid Rolls Required per Wall Length		
Type	Rolls / linear ft	Rolls / linear m
5XT	± 0.35	± 1.14
10XT	± 0.69	± 2.28
20XT	± 0.26	± 0.85

**Legend:**

= 28" (710mm) BLOCK

= 41" (1030 mm) BLOCK

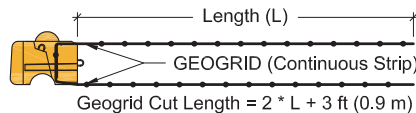

Geogrid shall be 12" (305 mm) wide strips of Mirafi geogrid, type as noted. Geogrid shall be **factory cut** and **certified** for width and strength by TenCate Mirafi.

**\* Geogrid length primarily controlled by global stability. Length will change with crest height.**

**SEE NOTES AND RECOMMENDED DETAILS AT START OF PRELIM. REINFORCEMENT SCHEDULE.**

# Preliminary Reinforcement Schedule

$\phi = 28^\circ$  | SILTY SAND or CLAYEY SAND

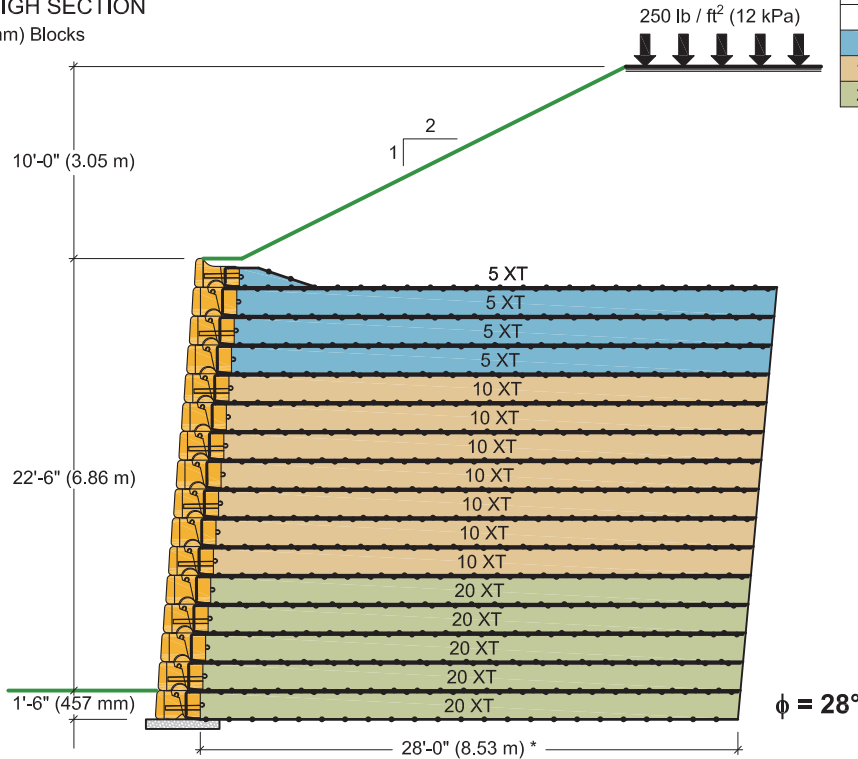

**LOAD CONDITION CR** | 1 : 2 CREST SLOPE, 10' (3.0 m) HIGH, 250 lb/ft<sup>2</sup> (12 kPa) SURCHARGE AT CREST, NO TOE SLOPE

16 BLOCK HIGH SECTION  
(16) 28" (710 mm) Blocks



Geogrid Rolls Required per Wall Length		
Type	Rolls / linear ft	Rolls / linear m
5XT	± 0.35	± 1.14
10XT	± 0.61	± 1.99
20XT	± 0.43	± 1.42

**Legend:**

-  = 28" (710mm) BLOCK
-  = 41" (1030 mm) BLOCK

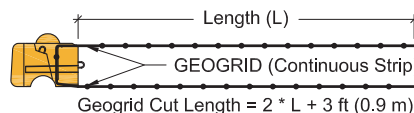

Geogrid shall be 12" (305 mm) wide strips of Mirafi geogrid, type as noted. Geogrid shall be **factory cut** and **certified** for width and strength by TenCate Mirafi.

**\* Geogrid length primarily controlled by global stability. Length will change with crest height.**

**SEE NOTES AND RECOMMENDED DETAILS AT START OF PRELIM. REINFORCEMENT SCHEDULE.**

# Preliminary Reinforcement Schedule

$\phi = 28^\circ$  | SILTY SAND or CLAYEY SAND

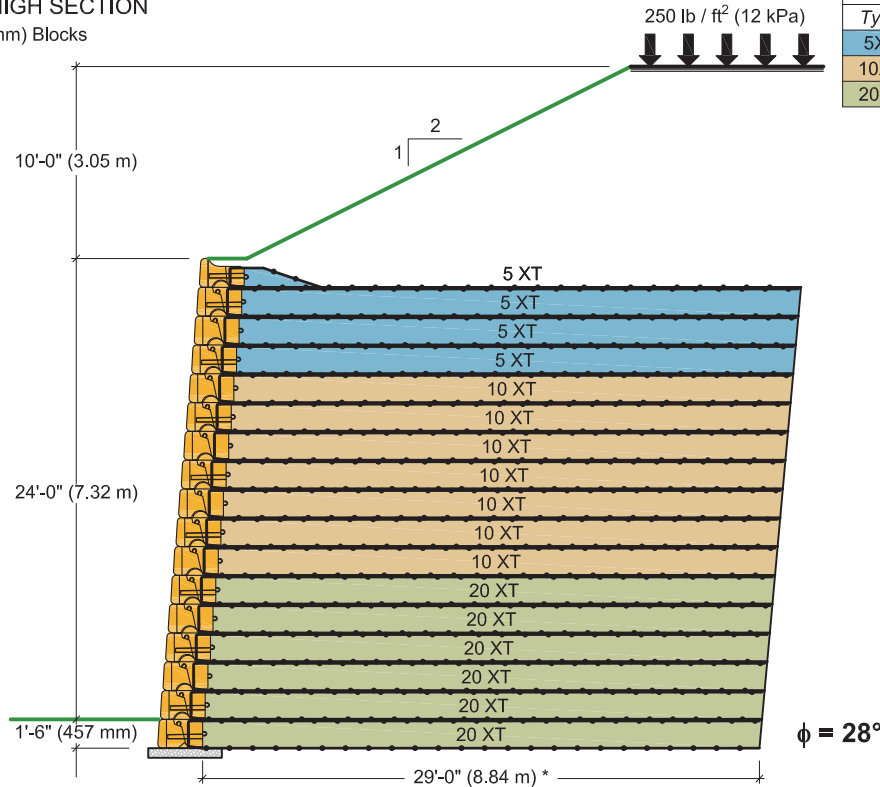

**LOAD CONDITION CR** | 1 : 2 CREST SLOPE, 10' (3.0 m) HIGH, 250 lb/ft<sup>2</sup> (12 kPa) SURCHARGE AT CREST, NO TOE SLOPE

17 BLOCK HIGH SECTION  
(17) 28" (710 mm) Blocks



Type	Rolls / linear ft	Rolls / linear m
5XT	± 0.35	± 1.14
10XT	± 0.61	± 1.99
20XT	± 0.52	± 1.71

**Legend:**

-  = 28" (710mm) BLOCK
-  = 41" (1030 mm) BLOCK

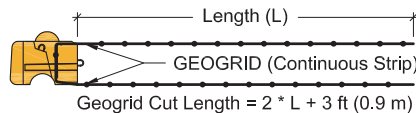

Geogrid shall be 12" (305 mm) wide strips of Mirafi geogrid, type as noted. Geogrid shall be **factory cut** and **certified** for width and strength by TenCate Mirafi.

**\* Geogrid length primarily controlled by global stability. Length will change with crest height.**

**SEE NOTES AND RECOMMENDED DETAILS AT START OF PRELIM. REINFORCEMENT SCHEDULE.**

# Preliminary Reinforcement Schedule

$\phi = 28^\circ$  | SILTY SAND or CLAYEY SAND

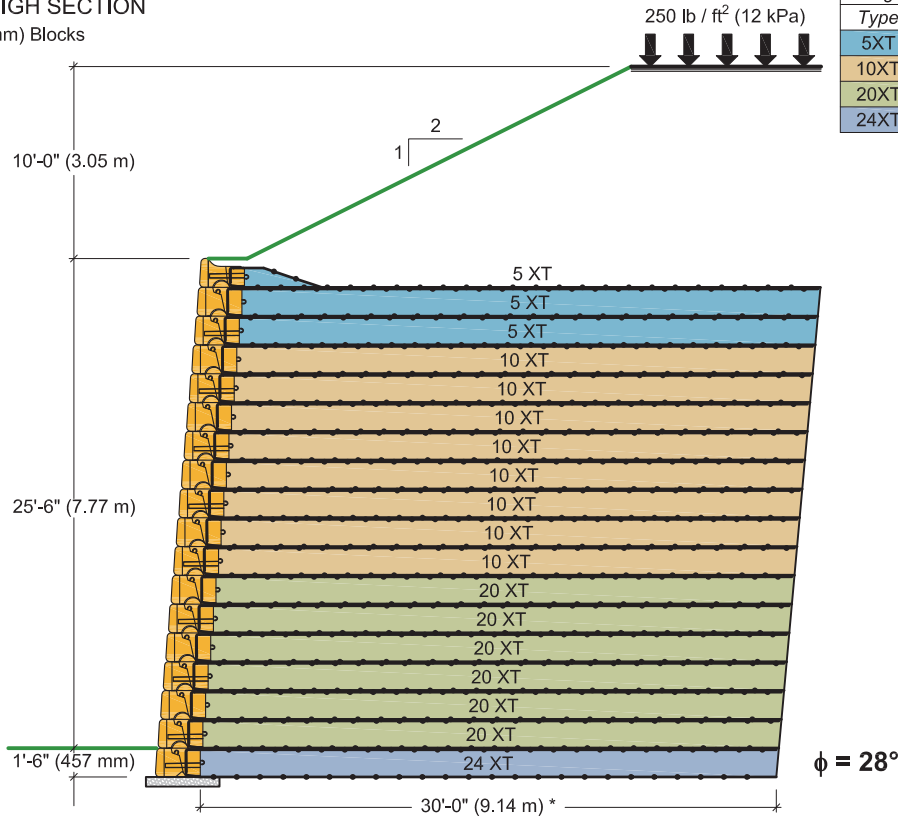

**LOAD CONDITION CR** | 1 : 2 CREST SLOPE, 10' (3.0 m) HIGH, 250 lb/ft<sup>2</sup> (12 kPa) SURCHARGE AT CREST, NO TOE SLOPE

18 BLOCK HIGH SECTION  
(18) 28" (710 mm) Blocks



Geogrid Rolls Required per Wall Length		
Type	Rolls / linear ft	Rolls / linear m
5XT	± 0.26	± 0.85
10XT	± 0.69	± 2.28
20XT	± 0.52	± 1.71
24XT	± 0.09	± 0.28

**Legend:**

-  = 28" (710mm) BLOCK
-  = 41" (1030 mm) BLOCK

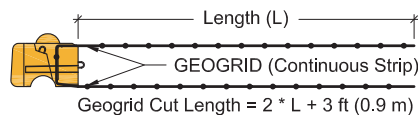

Geogrid shall be 12" (305 mm) wide strips of Mirafi geogrid, type as noted. Geogrid shall be **factory cut** and **certified** for width and strength by TenCate Mirafi.

**\* Geogrid length primarily controlled by global stability. Length will change with crest height.**

**SEE NOTES AND RECOMMENDED DETAILS AT START OF PRELIM. REINFORCEMENT SCHEDULE.**

# Preliminary Reinforcement Schedule

$\phi = 28^\circ$  | SILTY SAND or CLAYEY SAND

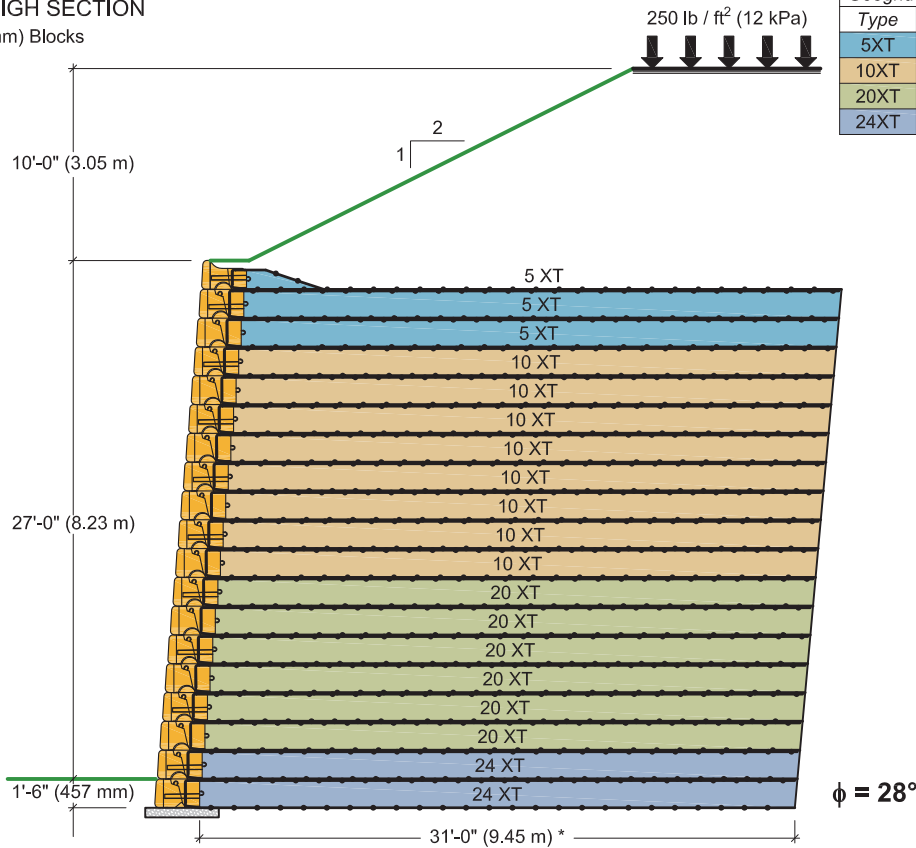

**LOAD CONDITION CR** | 1 : 2 CREST SLOPE, 10' (3.0 m) HIGH, 250 lb/ft<sup>2</sup> (12 kPa) SURCHARGE AT CREST, NO TOE SLOPE

19 BLOCK HIGH SECTION  
(19) 28" (710 mm) Blocks



Geogrid Rolls Required per Wall Length		
Type	Rolls / linear ft	Rolls / linear m
5XT	± 0.26	± 0.85
10XT	± 0.69	± 2.28
20XT	± 0.52	± 1.71
24XT	± 0.17	± 0.57

**Legend:**

-  = 28" (710mm) BLOCK
-  = 41" (1030 mm) BLOCK

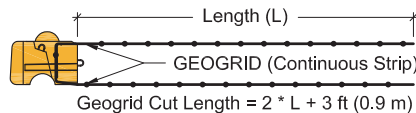

Geogrid shall be 12" (305 mm) wide strips of Mirafi geogrid, type as noted. Geogrid shall be **factory cut** and **certified** for width and strength by TenCate Mirafi.

**\* Geogrid length primarily controlled by global stability. Length will change with crest height.**

**SEE NOTES AND RECOMMENDED DETAILS AT START OF PRELIM. REINFORCEMENT SCHEDULE.**

# Preliminary Reinforcement Schedule

$\phi = 28^\circ$  | SILTY SAND or CLAYEY SAND

**LOAD CONDITION CR** | 1 : 2 CREST SLOPE, 10' (3.0 m) HIGH, 250 lb/ft<sup>2</sup> (12 kPa) SURCHARGE AT CREST, NO TOE SLOPE

20 BLOCK HIGH SECTION \*\*  
(20) 28" (710 mm) Blocks

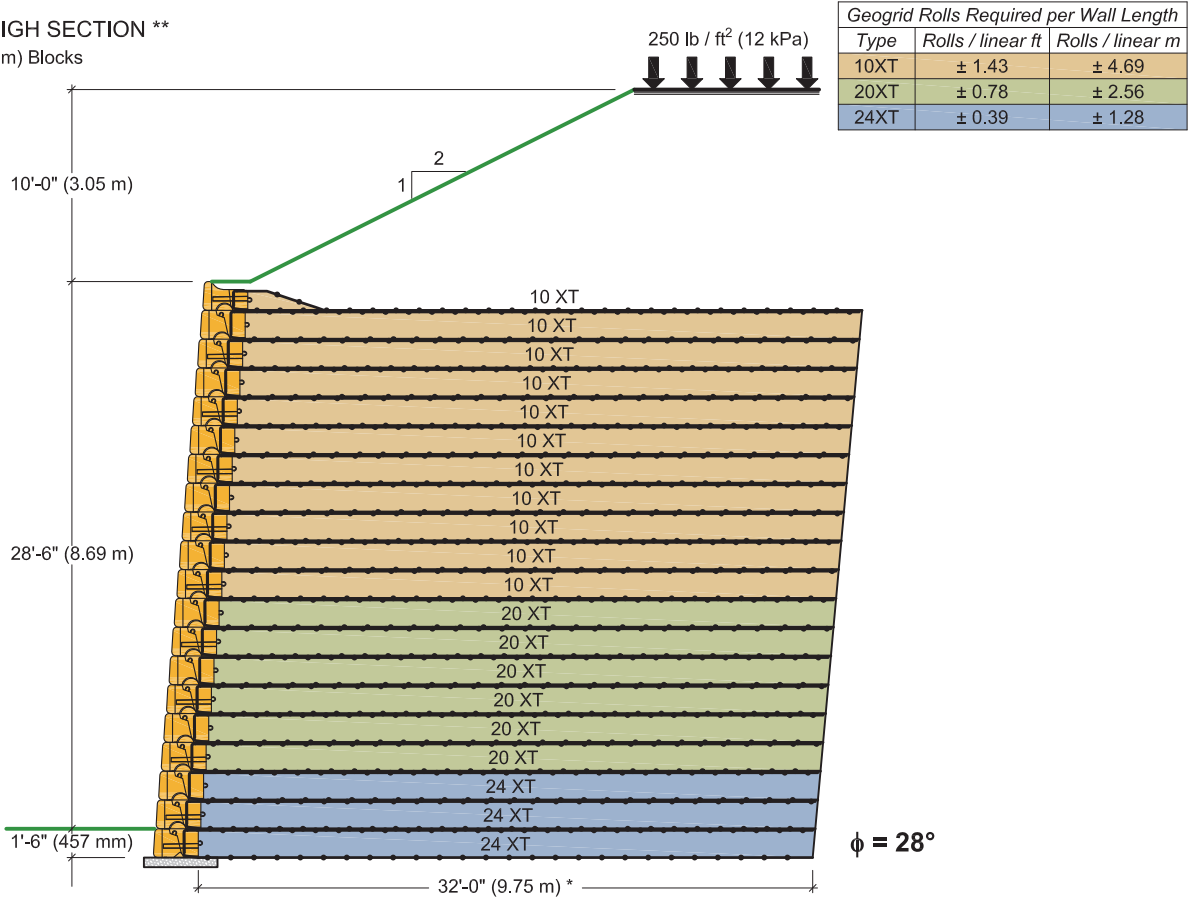

**Legend:**

= 28" (710mm) BLOCK

= 41" (1030 mm) BLOCK

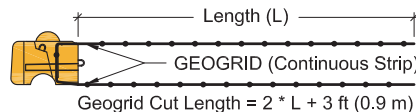

Geogrid shall be 12" (305 mm) wide strips of Mirafi geogrid, type as noted. Geogrid shall be **factory cut** and **certified** for width and strength by TenCate Mirafi.

\* **Geogrid length primarily controlled by global stability. Length will change with crest height.**

\*\* **Not tall enough? You can build significantly taller walls with the Redi-Rock PC System...we just had to stop the preliminary sections somewhere. Talk to your Engineer or give us a call for more info.**

**SEE NOTES AND RECOMMENDED DETAILS AT START OF PRELIM. REINFORCEMENT SCHEDULE.**





PRODUCT DATA SHEETS

## Redi-Rock 28" (710 mm) Retaining Blocks

The Redi-Rock 28" (710mm) Retaining wall blocks are machine-placed, wet-cast, precast modular block units manufactured from first-purpose, non-reconstituted concrete and intended for use in the construction of dry-stacked modular retaining wall systems. The block units are manufactured from structural-grade concrete mixes in accordance with ASTM C94 or ASTM C685 that produce a finished unit with excellent resistance to freeze-thaw, deicing chemical exposure, and submerged conditions in both fresh water and salt water applications. All Redi-Rock Retaining wall products are manufactured and distributed through an international network of individually-owned, licensed precast concrete manufacturers.

### DIMENSIONAL PROPERTIES

DIMENSIONS <sup>(1)</sup>	TOP	MIDDLE	BOTTOM	HALF TOP	HALF MIDDLE	HALF BOTTOM
HEIGHT (FRONT OF BLOCK)	18 ± 3/16 (457 ± 5)	18 ± 3/16 (457 ± 5)	18 ± 3/16 (457 ± 5)	18 ± 3/16 (457 ± 5)	18 ± 3/16 (457 ± 5)	18 ± 3/16 (457 ± 5)
HEIGHT (BACK OF BLOCK)	13 ± 3/16 (330 ± 5)	18 ± 3/16 (457 ± 5)	18 ± 3/16 (457 ± 5)	13 ± 3/16 (330 ± 5)	18 ± 3/16 (457 ± 5)	18 ± 3/16 (457 ± 5)
LENGTH (FRONT OF BLOCK)	46 1/8 ± 1/2 (1172 ± 13)			22 13/16 ± 1/4 (579 ± 6)		
LENGTH (BACK OF BLOCK)	40 ± 1/2 (1016 ± 13)			16 13/16 ± 1/4 (427 ± 6)		
WIDTH	22 5/8 ± 1/2 (575 ± 13) FORM LINE TO BACK OF BLOCK AND ± 5 3/8 (136) FACE TEXTURE					
CONCRETE VOLUME	TOP	MIDDLE	BOTTOM	HALF TOP	HALF MIDDLE	HALF BOTTOM
LIMESTONE/COBBLESTONE FACE	±8.57 ft <sup>3</sup> (0.243 m <sup>3</sup> )	±11.28 ft <sup>3</sup> (0.319 m <sup>3</sup> )	±12.19 ft <sup>3</sup> (0.345 m <sup>3</sup> )	±4.01 ft <sup>3</sup> (0.113 m <sup>3</sup> )	±5.23 ft <sup>3</sup> (0.148 m <sup>3</sup> )	±5.66 ft <sup>3</sup> (0.160 m <sup>3</sup> )
LEDGESTONE FACE	±8.07 ft <sup>3</sup> (0.229 m <sup>3</sup> )	±10.78 ft <sup>3</sup> (0.305 m <sup>3</sup> )	±11.70 ft <sup>3</sup> (0.331 m <sup>3</sup> )	±3.76 ft <sup>3</sup> (0.106 m <sup>3</sup> )	±4.98 ft <sup>3</sup> (0.141 m <sup>3</sup> )	±5.41 ft <sup>3</sup> (0.153 m <sup>3</sup> )
SHIPPING/HANDLING WEIGHT <sup>(2)</sup>	TOP	MIDDLE	BOTTOM	HALF TOP	HALF MIDDLE	HALF BOTTOM
LIMESTONE/COBBLESTONE FACE	± 1229 lb (557 kg)	± 1613 lb (732 kg)	± 1744 lb (791 kg)	± 573 lb (260 kg)	± 748 lb (339 kg)	± 809 lb (367 kg)
LEDGESTONE FACE	± 1158 lb (525 kg)	± 1542 lb (699 kg)	± 1672 lb (758 kg)	± 538 lb (244 kg)	± 713 lb (323 kg)	± 774 lb (351 kg)

<sup>(1)</sup> All dimensions are inches (mm).

<sup>(2)</sup> Weight shown is based on an assumed concrete unit weight of 143 lb/ft<sup>3</sup> (2291 kg/m<sup>3</sup>). Actual weights will vary.

### CONCRETE MIX PROPERTIES <sup>(2)</sup>

FREEZE THAW EXPOSURE CLASS <sup>(4)</sup>	MINIMUM 28 DAY COMPRESSIVE STRENGTH <sup>(5)</sup>	MAXIMUM WATER CEMENT RATIO	NOMINAL MAXIMUM AGGREGATE SIZE	AGGREGATE CLASS DESIGNATION <sup>(6)</sup>	AIR CONTENT <sup>(7)</sup>
MODERATE	4,000 psi (27.6 MPa)	0.45	1 inch (25 mm)	3M	4.5% ± 1.5%
SEVERE	4,000 psi (27.6 MPa)	0.45	1 inch (25 mm)	3S	6.0% ± 1.5%
VERY SEVERE	4,500 psi (30.0 MPa)	0.40	1 inch (25 mm)	4S	6.0% ± 1.5%
MAXIMUM WATER-SOLUBLE CHLORIDE ION (Cl <sup>-</sup> ) CONTENT IN CONCRETE, PERCENT BY WEIGHT OF CEMENT <sup>(8)</sup>					0.015
MAXIMUM CHLORIDE AS Cl <sup>-</sup> CONCENTRATION IN MIXING WATER, PARTS PER MILLION					1000
MAXIMUM PERCENTAGE OF TOTAL CEMENTITIOUS MATERIALS BY WEIGHT <sup>(9)</sup> (VERY SEVERE EXPOSURE CLASS ONLY)					
FLY ASH OR OTHER POZZOLANS CONFORMING TO ASTM C618					25
SLAG CONFORMING TO ASTM C989					50
SILICA FUME CONFORMING TO ASTM C1240					10
TOTAL OF FLY ASH OR OTHER POZZOLANS, SLAG, AND SILICA FUME <sup>(10)</sup>					50
TOTAL OF FLY ASH OR OTHER POZZOLANS AND SILICA FUME <sup>(10)</sup>					35

<sup>(3)</sup> Concrete mix properties are in general accordance with ACI 318 durability requirements. Research has shown that concrete manufactured to these standards demonstrates good durability and performance. When these requirements are followed, specific freeze-thaw testing of the concrete is typically NOT required.

<sup>(4)</sup> Exposure class is as described in ACI 318. "MODERATE" describes concrete that is exposed to freezing and thawing cycles and occasional exposure to moisture. "SEVERE" describes concrete that is exposed to freezing and thawing cycles and in continuous contact with moisture. "VERY SEVERE" describes concrete that is exposed to freezing and thawing cycles and in continuous contact with moisture and exposed to deicing chemicals. Exposure class should be specified by owner/purchaser prior to order placement. Longer lead times may be required for block units manufactured for "severe" and "very severe" exposure classes.

<sup>(5)</sup> Test method ASTM C39.

<sup>(6)</sup> Defined in ASTM C33 Table 3 *Limits for Deleterious Substances and Physical Property Requirements of Coarse Aggregate for Concrete*.

<sup>(7)</sup> Test method ASTM C231.

<sup>(8)</sup> Test method ASTM C1218 at age between 28 and 42 days.

<sup>(9)</sup> The total cementitious material also includes ASTM C150, C595, C845, and C1157 cement. The maximum percentages shall include:

- (a) Fly ash or other pozzolans in type IP, blended cement, ASTM C595, or ASTM C1157.
- (b) Slag used in the manufacture of an IS blended cement, ASTM C595, or ASTM C1157.
- (c) Silica fume, ASTM C1240, present in a blended cement.

<sup>(10)</sup> Fly ash or other pozzolans and silica fume shall constitute no more than 25 and 10 percent, respectively, of the total weight of the cementitious materials.

## Redi-Rock 28" (710 mm) Retaining Blocks

### DESIGN PROPERTIES

HORIZONTAL SETBACK / WALL FACE BATTER OPTIONS		BLOCK TO BLOCK INTERFACE SHEAR <sup>(12)</sup>
10 inch (254 mm) KNOB	1 5/8 inch (41 mm) PER BLOCK COURSE (5.2° BATTER)	$V = 6,061 + N \tan 44^\circ \leq 11,276 \text{ lb/ft} (88.4 + N \tan 44^\circ \leq 164.5 \text{ kN/m})$
7 1/2 inch (190 mm) KNOB	3/8 inch (10 mm) PER BLOCK COURSE (1.2° BATTER)	$V = 1,178 + N \tan 54^\circ \leq 10,970 \text{ lb/ft} (17.2 + N \tan 54^\circ \leq 160.1 \text{ kN/m})$
6 3/4 inch (171 mm) KNOB	NO SETBACK (NO BATTER) <sup>(11)</sup>	$V = 1,178 + N \tan 54^\circ \leq 10,970 \text{ lb/ft} (17.2 + N \tan 54^\circ \leq 160.1 \text{ kN/m})$
INFILLED UNIT WEIGHT FOR WALL STABILITY CALCULATIONS <sup>(13)</sup>		
LIMESTONE / COBBLESTONE BLOCKS		127 lb/ft <sup>3</sup> (2082 kg/m <sup>3</sup> )
LEDGESTONE BLOCKS		122 lb/ft <sup>3</sup> (1954 kg/m <sup>3</sup> )
MINIMUM CONSTRUCTION RADIUS <sup>(14)</sup>		
CONCAVE CURVE		14 ft 6 in (4.42 m)
CONVEX CURVE		14 ft 6 in (4.42 m)

<sup>(11)</sup> Special consideration should be given to the design of vertical retaining walls subject to active lateral earth pressure.

<sup>(12)</sup> Values based on full scale testing performed in October 2011. Copies of the full test reports are available at [www.redi-rock.com](http://www.redi-rock.com).

<sup>(13)</sup> The infilled unit weights shown here are based on an assumed concrete unit weight of 143 lb/ft<sup>3</sup> (2291 kg/m<sup>3</sup>) and an assumed soil unit weight of 100 lb/ft<sup>3</sup> (1602 kN/m<sup>3</sup>). They are reference values. Several factors can cause the unit weights of both concrete and infill soil to vary. The designer should use sound engineering judgement when assigning an infilled unit weight value for analysis.

<sup>(14)</sup> The minimum construction radius stated is applicable to both concave and convex curved retaining wall sections. Increases to this minimum radius are required to account for wall batter. Special consideration should be given to block selection, facing batter, and wall height when selecting the minimum radius for the final wall alignment.

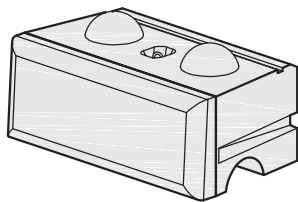
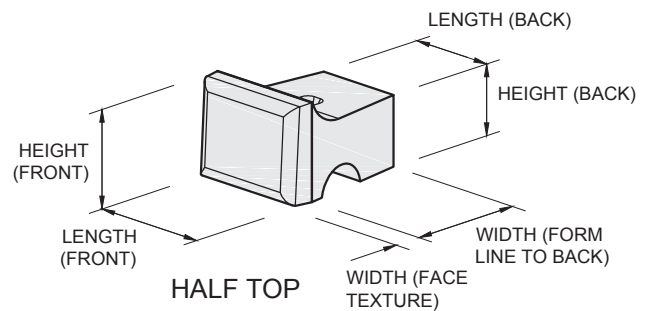
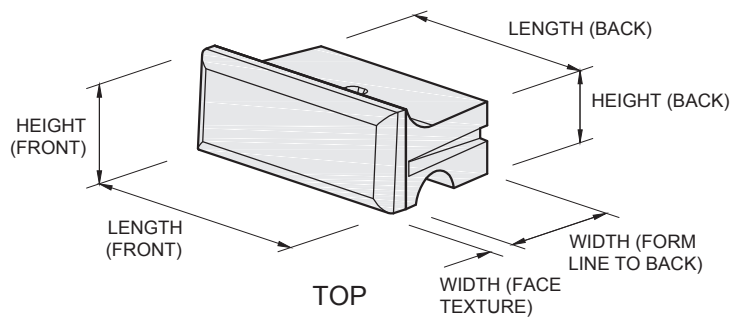

**MIDDLE**

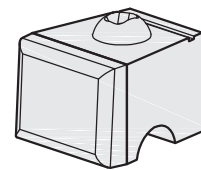

**HALF MIDDLE**

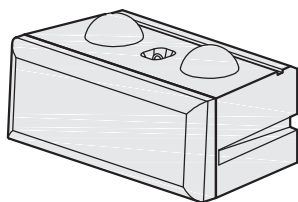

**BOTTOM**

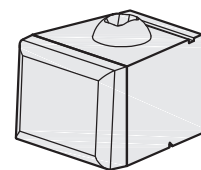

**HALF BOTTOM**

Revised 032315

## Redi-Rock 41" (1030 mm) Retaining Blocks

The Redi-Rock 41" (1030mm) Retaining wall blocks are machine-placed, wet-cast, precast modular block units manufactured from first-purpose, non-reconstituted concrete and intended for use in the construction of dry-stacked modular retaining wall systems. The block units are manufactured from structural-grade concrete mixes in accordance with ASTM C94 or ASTM C685 that produce a finished unit with excellent resistance to freeze-thaw, deicing chemical exposure, and submerged conditions in both fresh water and salt water applications. All Redi-Rock Retaining wall products are manufactured and distributed through an international network of individually-owned, licensed precast concrete manufacturers.

### DIMENSIONAL PROPERTIES

DIMENSIONS <sup>(1)</sup>	TOP	MIDDLE	BOTTOM	HALF TOP	HALF MIDDLE	HALF BOTTOM
HEIGHT (FRONT OF BLOCK)	18 ± 3/16 (457 ± 5)	18 ± 3/16 (457 ± 5)	18 ± 3/16 (457 ± 5)	18 ± 3/16 (457 ± 5)	18 ± 3/16 (457 ± 5)	18 ± 3/16 (457 ± 5)
HEIGHT (BACK OF BLOCK)	13 ± 3/16 (330 ± 5)	18 ± 3/16 (457 ± 5)	18 ± 3/16 (457 ± 5)	13 ± 3/16 (330 ± 5)	18 ± 3/16 (457 ± 5)	18 ± 3/16 (457 ± 5)
LENGTH (FRONT OF BLOCK)	46 1/8 ± 1/2 (1172 ± 13)			22 13/16 ± 1/4 (579 ± 6)		
LENGTH (BACK OF BLOCK)	36 5/8 ± 1/2 (930 ± 13)			13 3/16 ± 1/4 (344 ± 6)		
WIDTH	35 3/8 ± 1/2 (892 ± 13) FORM LINE TO BACK OF BLOCK AND ± 5 3/8 (136) FACE TEXTURE					
CONCRETE VOLUME	BOTTOM	MIDDLE	BOTTOM	HALF MIDDLE	HALF MIDDLE	HALF BOTTOM
LIMESTONE/COBBLESTONE FACE	±12.22 ft <sup>3</sup> (0.346 m <sup>3</sup> )	±16.14 ft <sup>3</sup> (0.457 m <sup>3</sup> )	±17.06 ft <sup>3</sup> (0.483 m <sup>3</sup> )	±5.38 ft <sup>3</sup> (0.15 m <sup>3</sup> )	±7.14 ft <sup>3</sup> (0.202 m <sup>3</sup> )	±7.58 ft <sup>3</sup> (0.214 m <sup>3</sup> )
LEDGESTONE FACE	±11.73 ft <sup>3</sup> (0.332 m <sup>3</sup> )	±15.65 ft <sup>3</sup> (0.443 m <sup>3</sup> )	±16.56 ft <sup>3</sup> (0.469 m <sup>3</sup> )	±5.14 ft <sup>3</sup> (0.15 m <sup>3</sup> )	±6.90 ft <sup>3</sup> (0.195 m <sup>3</sup> )	±7.33 ft <sup>3</sup> (0.208 m <sup>3</sup> )
SHIPPING/HANDLING WEIGHT <sup>(2)</sup>	MIDDLE		BOTTOM	HALF MIDDLE	HALF MIDDLE	HALF BOTTOM
LIMESTONE/COBBLESTONE FACE	± 1748 lb (793 kg)	± 2309 lb (1047 kg)	± 2439 lb (1106 kg)	± 770 lb (350 kg)	± 1022 lb (463 kg)	±1083 lb (491 kg)
LEDGESTONE FACE	± 1677 lb (760 kg)	± 2237 lb (1015 kg)	± 2368 lb (1074 kg)	± 735 lb (333 kg)	± 987 lb (448 kg)	± 1048 lb (475 kg)

<sup>(1)</sup> All dimensions are inches (mm).

<sup>(2)</sup> Weight shown is based on an assumed concrete unit weight of 143 lb/ft<sup>3</sup> (2291 kg/m<sup>3</sup>). Actual weights will vary.

### CONCRETE MIX PROPERTIES <sup>(3)</sup>

FREEZE THAW EXPOSURE CLASS <sup>(4)</sup>	MINIMUM 28 DAY COMPRESSIVE STRENGTH <sup>(5)</sup>	MAXIMUM WATER CEMENT RATIO	NOMINAL MAXIMUM AGGREGATE SIZE	AGGREGATE CLASS DESIGNATION <sup>(6)</sup>	AIR CONTENT <sup>(7)</sup>
MODERATE	4,000 psi (27.6 MPa)	0.45	1 inch (25 mm)	3M	4.5% ± 1.5%
SEVERE	4,000 psi (27.6 MPa)	0.45	1 inch (25 mm)	3S	6.0% ± 1.5%
VERY SEVERE	4,500 psi (30.0 MPa)	0.40	1 inch (25 mm)	4S	6.0% ± 1.5%
MAXIMUM WATER-SOLUBLE CHLORIDE ION (Cl <sup>-</sup> ) CONTENT IN CONCRETE, PERCENT BY WEIGHT OF CEMENT <sup>(8)</sup>					0.015
MAXIMUM CHLORIDE AS Cl <sup>-</sup> CONCENTRATION IN MIXING WATER, PARTS PER MILLION					1000
MAXIMUM PERCENTAGE OF TOTAL CEMENTITIOUS MATERIALS BY WEIGHT <sup>(9, 11)</sup> (VERY SEVERE EXPOSURE CLASS ONLY)					
FLY ASH OR OTHER POZZOLANS CONFORMING TO ASTM C618					25
SLAG CONFORMING TO ASTM C989					50
SILICA FUME CONFORMING TO ASTM C1240					10
TOTAL OF FLY ASH OR OTHER POZZOLANS, SLAG, AND SILICA FUME <sup>(10)</sup>					50
TOTAL OF FLY ASH OR OTHER POZZOLANS AND SILICA FUME <sup>(10)</sup>					35
ALKALI-AGGREGATE REACTIVITY MITIGATION PER ACI 201					

<sup>(3)</sup> Concrete mix properties are in general accordance with ACI 318 durability requirements. Research has shown that concrete manufactured to these standards demonstrates good durability and performance. When these requirements are followed, specific freeze-thaw testing of the concrete is typically NOT required.

<sup>(4)</sup> Exposure class is as described in ACI 318. "MODERATE" describes concrete that is exposed to freezing and thawing cycles and occasional exposure to moisture. "SEVERE" describes concrete that is exposed to freezing and thawing cycles and in continuous contact with moisture. "VERY SEVERE" describes concrete that is exposed to freezing and thawing cycles and in continuous contact with moisture and exposed to deicing chemicals. Exposure class should be specified by owner/purchaser prior to order placement. Longer lead times may be required for block units manufactured for "severe" and "very severe" exposure classes.

<sup>(5)</sup> Test method ASTM C39.

<sup>(6)</sup> Defined in ASTM C33 Table 3 *Limits for Deleterious Substances and Physical Property Requirements of Coarse Aggregate for Concrete*.

<sup>(7)</sup> Test method ASTM C231.

<sup>(8)</sup> Test method ASTM C1218 at age between 28 and 42 days.

<sup>(9)</sup> The total cementitious material also includes ASTM C150, C595, C845, and C1157 cement. The maximum percentages shall include:

- (a) Fly ash or other pozzolans in type IP, blended cement, ASTM C595, or ASTM C1157.
- (b) Slag used in the manufacture of an IS blended cement, ASTM C595, or ASTM C1157.
- (c) Silica fume, ASTM C1240, present in a blended cement.

<sup>(10)</sup> Fly ash or other pozzolans and silica fume shall constitute no more than 25 and 10 percent, respectively, of the total weight of the cementitious materials.

<sup>(11)</sup> Prescriptive limits shown may be waived for concrete mixes that demonstrate excellent freeze/thaw durability in a detailed and current testing program.

## Redi-Rock 41" (1030 mm) Retaining Blocks

### DESIGN PROPERTIES

HORIZONTAL SETBACK / WALL FACE BATTER OPTIONS		BLOCK TO BLOCK INTERFACE SHEAR <sup>(13)</sup>
10 inch (254 mm) KNOB	1 5/8 inch (41 mm) PER BLOCK COURSE (5.2° BATTER)	$V = 6,061 + N \tan 44^\circ \leq 11,276 \text{ lb/ft}$ ( $88.4 + N \tan 44^\circ \leq 164.5 \text{ kN/m}$ )
7 1/2 inch (190 mm) KNOB	3/8 inch (10 mm) PER BLOCK COURSE (1.2° BATTER)	$V = 1,178 + N \tan 54^\circ \leq 10,970 \text{ lb/ft}$ ( $17.2 + N \tan 54^\circ \leq 160.1 \text{ kN/m}$ )
6 3/4 inch (171 mm) KNOB	NO SETBACK (NO BATTER) <sup>(12)</sup>	$V = 1,178 + N \tan 54^\circ \leq 10,970 \text{ lb/ft}$ ( $17.2 + N \tan 54^\circ \leq 160.1 \text{ kN/m}$ )
INFILLED UNIT WEIGHT FOR WALL STABILITY CALCULATIONS <sup>(14)</sup>		
LIMESTONE / COBBLESTONE BLOCKS		130 lb/ft <sup>3</sup> (2082 kg/m <sup>3</sup> )
LEDGESTONE BLOCKS		126 lb/ft <sup>3</sup> (2018 kg/m <sup>3</sup> )
MINIMUM CONSTRUCTION RADIUS <sup>(15)</sup>		
CONCAVE CURVE		14 ft 6 in (4.42 m)
CONVEX CURVE		14 ft 6 in (4.42 m)

<sup>(12)</sup> Special consideration should be given to the design of vertical retaining walls subject to active lateral earth pressure.

<sup>(13)</sup> Values based on full scale testing performed in October 2011. Copies of the full test reports are available at [www.redi-rock.com](http://www.redi-rock.com).

<sup>(14)</sup> The infilled unit weights shown here are based on an assumed concrete unit weight of 143 lb/ft<sup>3</sup> (2291 kg/m<sup>3</sup>) and an assumed soil unit weight of 100 lb/ft<sup>3</sup> (1602 kg/m<sup>3</sup>). They are reference values. Several factors can cause the unit weights of both concrete and infill soil to vary. The designer should use sound engineering judgement when assigning an infilled unit weight value for analysis.

<sup>(15)</sup> The minimum construction radius stated is applicable to both concave and convex curved retaining wall sections. Increases to this minimum radius are required to account for wall batter. Special consideration should be given to block selection, facing batter, and wall height when selecting the minimum radius for the final wall alignment.

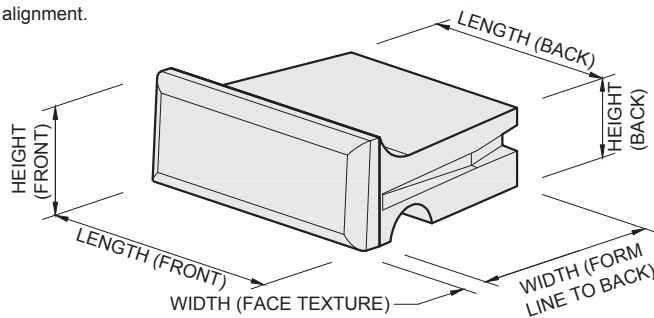

TOP

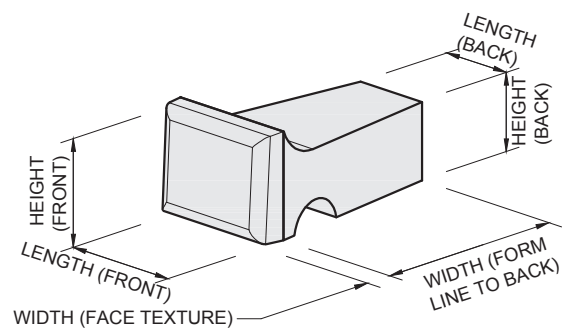

HALF TOP

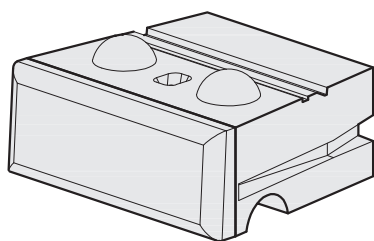

MIDDLE

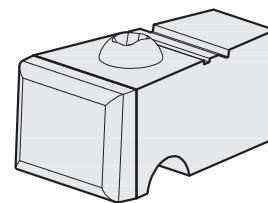

HALF MIDDLE

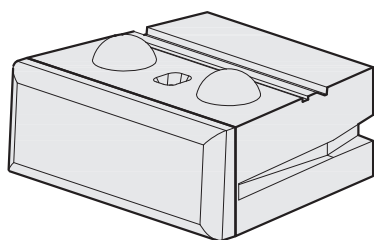

BOTTOM

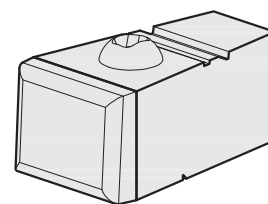

HALF BOTTOM

Revised 032315

## Redi-Rock 60" (1520 mm) Retaining Blocks

The Redi-Rock 60" (1520mm) Retaining wall blocks are machine-placed, wet-cast, precast modular block units manufactured from first-purpose, non-reconstituted concrete and intended for constructing dry-stacked modular retaining wall systems. The block units are manufactured from structural-grade concrete mixes in accordance with ASTM C94 or ASTM C685 that produce a finished unit with excellent resistance to freeze-thaw, deicing chemical exposure, and submerged conditions in both fresh water and salt water applications. All Redi-Rock Retaining wall products are manufactured and distributed through an international network of individually-owned, licensed precast concrete manufacturers.

### DIMENSIONAL PROPERTIES

DIMENSIONS <sup>(1)</sup>	MIDDLE	BOTTOM	HALF MIDDLE	HALF BOTTOM
HEIGHT (FRONT OF BLOCK)	18 ± 3/16 (457 ± 5)	18 ± 3/16 (457 ± 5)	18 ± 3/16 (457 ± 5)	18 ± 3/16 (457 ± 5)
HEIGHT (BACK OF BLOCK)	18 ± 3/16 (457 ± 5)	18 ± 3/16 (457 ± 5)	18 ± 3/16 (457 ± 5)	18 ± 3/16 (457 ± 5)
LENGTH (FRONT OF BLOCK)	46 1/8 ± 1/2 (1172 ± 13)		46 1/8 ± 1/2 (1172 ± 13)	
LENGTH (BACK OF BLOCK)	31 3/8 ± 1/2 (797 ± 13)		8 3/8 ± 1/2 (231 ± 13)	
WIDTH	54 5/8 ± 1/2 (1387 ± 13) PLUS ± 5 3/8 (136) FACE TEXTURE		54 5/8 ± 1/2 (1387 ± 13) PLUS ± 5 3/8 (136) FACE TEXTURE	
CONCRETE VOLUME	MIDDLE	BOTTOM	HALF MIDDLE	HALF BOTTOM
LIMESTONE/COBBLESTONE FACE	± 23.00 ft <sup>3</sup> (0.651 m <sup>3</sup> )	± 23.90 ft <sup>3</sup> (0.677 m <sup>3</sup> )	± 9.34 ft <sup>3</sup> (0.264 m <sup>3</sup> )	± 9.77 ft <sup>3</sup> (0.277 m <sup>3</sup> )
LEDGESTONE FACE	± 22.49 ft <sup>3</sup> (0.637 m <sup>3</sup> )	± 23.40 ft <sup>3</sup> (0.663 m <sup>3</sup> )	± 9.09 ft <sup>3</sup> (0.258 m <sup>3</sup> )	± 9.52 ft <sup>3</sup> (0.270 m <sup>3</sup> )
SHIPPING/HANDLING WEIGHT <sup>(2)</sup>	MIDDLE	BOTTOM	HALF MIDDLE	HALF BOTTOM
LIMESTONE/COBBLESTONE FACE	± 3287 lb (1491 kg)	± 3418 lb (1550 kg)	± 1335 lb (606 kg)	± 1397 lb (633 kg)
LEDGESTONE FACE	± 3216 lb (1458 kg)	± 3346 lb (1518 kg)	± 1300 lb (590 kg)	± 1364 lb (618 kg)

<sup>(1)</sup> All dimensions are inches (mm).

<sup>(2)</sup> Weight shown is based on an assumed concrete unit weight of 143 lb/ft<sup>3</sup> (2291 kg/m<sup>3</sup>). Actual weights will vary.

### CONCRETE MIX PROPERTIES <sup>(3)</sup>

FREEZE THAW EXPOSURE CLASS <sup>(4)</sup>	MINIMUM 28 DAY COMPRESSIVE STRENGTH <sup>(5)</sup>	MAXIMUM WATER CEMENT RATIO	NOMINAL MAXIMUM AGGREGATE SIZE	AGGREGATE CLASS DESIGNATION <sup>(6)</sup>	AIR CONTENT <sup>(7)</sup>
MODERATE	4,000 psi (27.6 MPa)	0.45	1 inch (25 mm)	3M	4.5% ± 1.5%
SEVERE	4,000 psi (27.6 MPa)	0.45	1 inch (25 mm)	3S	6.0% ± 1.5%
VERY SEVERE	4,500 psi (30.0 MPa)	0.40	1 inch (25 mm)	4S	6.0% ± 1.5%
MAXIMUM WATER-SOLUBLE CHLORIDE ION (Cl <sup>-</sup> ) CONTENT IN CONCRETE, PERCENT BY WEIGHT OF CEMENT <sup>(8)</sup>					0.015
MAXIMUM CHLORIDE AS Cl <sup>-</sup> CONCENTRATION IN MIXING WATER, PARTS PER MILLION					1000
MAXIMUM PERCENTAGE OF TOTAL CEMENTITIOUS MATERIALS BY WEIGHT <sup>(9, 11)</sup> (VERY SEVERE EXPOSURE CLASS ONLY)					
FLY ASH OR OTHER POZZOLANS CONFORMING TO ASTM C618					25
SLAG CONFORMING TO ASTM C989					50
SILICA FUME CONFORMING TO ASTM C1240					10
TOTAL OF FLY ASH OR OTHER POZZOLANS, SLAG, AND SILICA FUME <sup>(10)</sup>					50
TOTAL OF FLY ASH OR OTHER POZZOLANS AND SILICA FUME <sup>(10)</sup>					35
ALKALI-AGGREGATE REACTIVITY MITIGATION PER ACI 201					

<sup>(3)</sup> Concrete mix properties are in general accordance with ACI 318 durability requirements. Research has shown that concrete manufactured to these standards demonstrates good durability and performance. When these requirements are followed, specific freeze-thaw testing of the concrete is typically NOT required.

<sup>(4)</sup> Exposure class is as described in ACI 318. "MODERATE" describes concrete that is exposed to freezing and thawing cycles and occasional exposure to moisture. "SEVERE" describes concrete that is exposed to freezing and thawing cycles and in continuous contact with moisture. "VERY SEVERE" describes concrete that is exposed to freezing and thawing cycles and in continuous contact with moisture and exposed to deicing chemicals. Exposure class should be specified by owner/purchaser prior to order placement. Longer lead times may be required for block units manufactured for "severe" and "very severe" exposure classes.

<sup>(5)</sup> Test method ASTM C39.

<sup>(6)</sup> Defined in ASTM C33 Table 3 *Limits for Deleterious Substances and Physical Property Requirements of Coarse Aggregate for Concrete*.

<sup>(7)</sup> Test method ASTM C231.

<sup>(8)</sup> Test method ASTM C1218 at age between 28 and 42 days.

<sup>(9)</sup> The total cementitious material also includes ASTM C150, C595, C845, and C1157 cement. The maximum percentages shall include:

- (a) Fly ash or other pozzolans in type IP, blended cement, ASTM C595, or ASTM C1157.
- (b) Slag used in the manufacture of an IS blended cement, ASTM C595, or ASTM C1157.
- (c) Silica fume, ASTM C1240, present in a blended cement.

<sup>(10)</sup> Fly ash or other pozzolans and silica fume shall constitute no more than 25 and 10 percent, respectively, of the total weight of the cementitious materials.

<sup>(11)</sup> Prescriptive limits shown may be waived for concrete mixes that demonstrate excellent freeze/thaw durability in a detailed and current testing program.

## Redi-Rock 60" (1520 mm) Retaining Blocks

### DESIGN PROPERTIES

HORIZONTAL SETBACK / WALL FACE BATTER OPTIONS		BLOCK TO BLOCK INTERFACE SHEAR <sup>(13)</sup>
10 inch (254 mm) KNOB	1 5/8 inch (41 mm) PER BLOCK COURSE (5.2° BATTER)	$V = 6,061 + N \tan 44^\circ \leq 11,276 \text{ lb/ft} (88.4 + N \tan 44^\circ \leq 164.5 \text{ kN/m})$
7 1/2 inch (190 mm) KNOB	3/8 inch (10 mm) PER BLOCK COURSE (1.2° BATTER)	$V = 1,178 + N \tan 54^\circ \leq 10,970 \text{ lb/ft} (17.2 + N \tan 54^\circ \leq 160.1 \text{ kN/m})$
6 3/4 inch (171 mm) KNOB	NO SETBACK (NO BATTER) <sup>(12)</sup>	$V = 1,178 + N \tan 54^\circ \leq 10,970 \text{ lb/ft} (17.2 + N \tan 54^\circ \leq 160.1 \text{ kN/m})$
INFILLED UNIT WEIGHT FOR WALL STABILITY CALCULATIONS <sup>(14)</sup>		
LIMESTONE / COBBLESTONE BLOCKS		60" (1520) BOTTOM RETAINING UNIT: 134 lb/ft <sup>3</sup> (2146 kg/m <sup>3</sup> ) 60" (1520) MIDDLE RETAINING UNIT: 130 lb/ft <sup>3</sup> (2082 kg/m <sup>3</sup> )
LEDGESTONE BLOCKS		132 lb/ft <sup>3</sup> (2114 kg/m <sup>3</sup> ) 128 lb/ft <sup>3</sup> (2050 kg/m <sup>3</sup> )
MINIMUM CONSTRUCTION RADIUS <sup>(15)</sup>		
CONCAVE CURVE		14 ft 6 in (4.42 m)
CONVEX CURVE		14 ft 6 in (4.42 m)

<sup>(12)</sup> Special consideration should be given to the design of vertical retaining walls subject to active lateral earth pressure.

<sup>(13)</sup> Values based on full scale testing performed in October 2011. Copies of the full test reports are available at [www.redi-rock.com](http://www.redi-rock.com).

<sup>(14)</sup> The infilled unit weights shown here are based on full width units and an assumed concrete unit weight of 143 lb/ft<sup>3</sup> (2291 kg/m<sup>3</sup>) and an assumed soil unit weight of 100 lb/ft<sup>3</sup> (1602 kg/m<sup>3</sup>). They are reference values. Several factors can cause the unit weights of both concrete and infill soil to vary. The designer should use sound engineering judgement when assigning an infilled unit weight value for analysis.

<sup>(15)</sup> The minimum construction radius stated is applicable to both concave and convex curved retaining wall sections. Increases to this minimum radius are required to account for wall batter. Special consideration should be given to block selection, facing batter, and wall height when selecting the minimum radius for the final wall alignment.

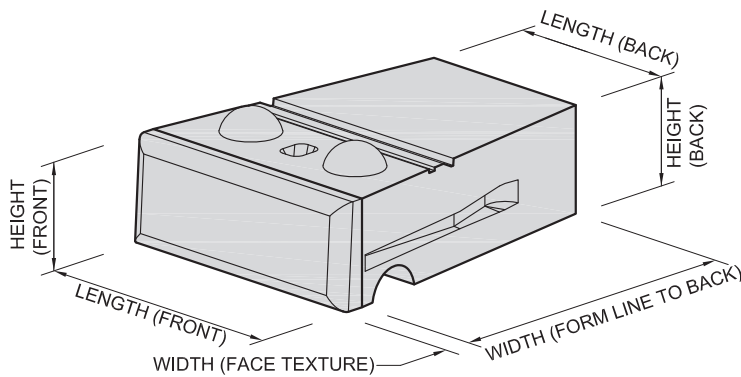

MIDDLE - 60" (1520)

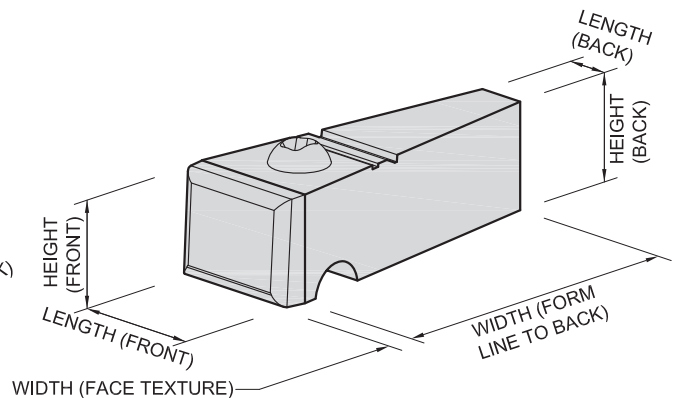

HALF MIDDLE - 60" (1520)

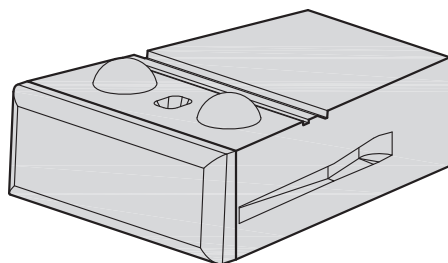

BOTTOM - 60" (1520)

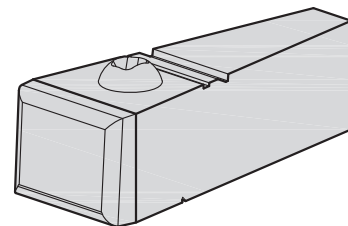

HALF BOTTOM - 60" (1520)

Revised 052015

## Redi-Rock 41" (1030 mm) wide, 9" (230 mm) Setback Retaining Blocks

The Redi-Rock 9" (230mm) Setback Retaining wall blocks are machine-placed, wet-cast, precast modular block units manufactured from first-purposed, non-reconstituted concrete and intended for use in the construction of dry-stacked modular retaining wall systems. The block units are manufactured from structural-grade concrete mixes in accordance with ASTM C94 or ASTM C685 that produce a finished unit with excellent resistance to freeze-thaw, deicing chemical exposure, and submerged conditions in both fresh water and salt water applications. All Redi-Rock Retaining wall products are manufactured and distributed through an international network of individually-owned, licensed precast concrete manufacturers.

### DIMENSIONAL PROPERTIES

DIMENSIONS <sup>(1)</sup>	MIDDLE	BOTTOM	HALF MIDDLE	HALF BOTTOM
HEIGHT (FRONT OF BLOCK)	18 ± 3/16 (457 ± 5)	18 ± 3/16 (457 ± 5)	18 ± 3/16 (457 ± 5)	18 ± 3/16 (457 ± 5)
HEIGHT (BACK OF BLOCK)	18 ± 3/16 (457 ± 5)	18 ± 3/16 (457 ± 5)	18 ± 3/16 (457 ± 5)	18 ± 3/16 (457 ± 5)
LENGTH (FRONT OF BLOCK)	46 5/8 ± 1/2 (1172 ± 13)		22 13/16 ± 1/4 (579 ± 6)	
LENGTH (BACK OF BLOCK)	36 5/8 ± 1/2 (930 ± 13)		13 3/16 ± 1/4 (344 ± 6)	
WIDTH	35 5/8 ± 1/2 (892 ± 13) FORM LINE TO BACK OF BLOCK AND ± 5 3/8 (136) FACE TEXTURE			
CONCRETE VOLUME	MIDDLE	BOTTOM	HALF MIDDLE	HALF BOTTOM
LIMESTONE/COBBLESTONE FACE	±16.21 ft <sup>3</sup> (0.459 m <sup>3</sup> )	±17.13 ft <sup>3</sup> (0.48 m <sup>3</sup> )	±7.20 ft <sup>3</sup> (0.20 m <sup>3</sup> )	±7.63 ft <sup>3</sup> (0.22 m <sup>3</sup> )
LEDGESTONE FACE	±15.72 ft <sup>3</sup> (0.445 m <sup>3</sup> )	±16.63 ft <sup>3</sup> (0.47 m <sup>3</sup> )	±6.96 ft <sup>3</sup> (0.20 m <sup>3</sup> )	±7.39 ft <sup>3</sup> (0.21 m <sup>3</sup> )
SHIPPING/HANDLING WEIGHT <sup>(2)</sup>	MIDDLE	BOTTOM	HALF MIDDLE	HALF BOTTOM
LIMESTONE/COBBLESTONE FACE	± 2319 lb (1051 kg)	± 2449 lb (1111 kg)	± 1030 lb (467 kg)	±1092 lb (495 kg)
LEDGESTONE FACE	± 2247 lb (1019 kg)	± 2378 lb (1078 kg)	± 995 lb (451 kg)	± 1057 lb (479 kg)

<sup>(1)</sup> All dimensions are inches (mm).

<sup>(2)</sup> Weight shown is based on an assumed concrete unit weight of 143 lb/ft<sup>3</sup> (2291kg/m<sup>3</sup>). Actual weights will vary.

### CONCRETE MIX PROPERTIES <sup>(3)</sup>

FREEZE THAW EXPOSURE CLASS <sup>(4)</sup>	MINIMUM 28 DAY COMPRESSIVE STRENGTH <sup>(5)</sup>	MAXIMUM WATER CEMENT RATIO	NOMINAL MAXIMUM AGGREGATE SIZE	AGGREGATE CLASS DESIGNATION <sup>(6)</sup>	AIR CONTENT <sup>(7)</sup>
MODERATE	4,000 psi (27.6 MPa)	0.45	1 inch (25 mm)	3M	4.5% ± 1.5%
SEVERE	4,000 psi (27.6 MPa)	0.45	1 inch (25 mm)	3S	6.0% ± 1.5%
VERY SEVERE	4,500 psi (30.0 MPa)	0.40	1 inch (25 mm)	4S	6.0% ± 1.5%
MAXIMUM WATER-SOLUBLE CHLORIDE ION (Cl <sup>-</sup> ) CONTENT IN CONCRETE, PERCENT BY WEIGHT OF CEMENT <sup>(8)</sup>					0.015
MAXIMUM CHLORIDE AS Cl <sup>-</sup> CONCENTRATION IN MIXING WATER, PARTS PER MILLION					1000
MAXIMUM PERCENTAGE OF TOTAL CEMENTITIOUS MATERIALS BY WEIGHT <sup>(9, 11)</sup> (VERY SEVERE EXPOSURE CLASS ONLY)					
FLY ASH OR OTHER POZZOLANS CONFORMING TO ASTM C618					25
SLAG CONFORMING TO ASTM C989					50
SILICA FUME CONFORMING TO ASTM C1240					10
TOTAL OF FLY ASH OR OTHER POZZOLANS, SLAG, AND SILICA FUME <sup>(10)</sup>					50
TOTAL OF FLY ASH OR OTHER POZZOLANS AND SILICA FUME <sup>(10)</sup>					35
ALKALI-AGGREGATE REACTIVITY MITIGATION PER ACI 201					

<sup>(3)</sup> Concrete mix properties are in general accordance with ACI 318 durability requirements. Research has shown that concrete manufactured to these standards demonstrates good durability and performance. When these requirements are followed, specific freeze-thaw testing of the concrete is typically NOT required.

<sup>(4)</sup> Exposure class is as described in ACI 318. "MODERATE" describes concrete that is exposed to freezing and thawing cycles and occasional exposure to moisture. "SEVERE" describes concrete that is exposed to freezing and thawing cycles and in continuous contact with moisture. "VERY SEVERE" describes concrete that is exposed to freezing and thawing cycles and in continuous contact with moisture and exposed to deicing chemicals. Exposure class should be specified by owner/purchaser prior to order placement. Longer lead times may be required for block units manufactured for "severe" and "very severe" exposure classes.

<sup>(5)</sup> Test method ASTM C39.

<sup>(6)</sup> Defined in ASTM C33 Table 3 *Limits for Deleterious Substances and Physical Property Requirements of Coarse Aggregate for Concrete*.

<sup>(7)</sup> Test method ASTM C231.

<sup>(8)</sup> Test method ASTM C1218 at age between 28 and 42 days.

<sup>(9)</sup> The total cementitious material also includes ASTM C150, C595, C845, and C1157 cement. The maximum percentages shall include:

- (a) Fly ash or other pozzolans in type IP, blended cement, ASTM C595, or ASTM C1157.
- (b) Slag used in the manufacture of an IS blended cement, ASTM C595, or ASTM C1157.
- (c) Silica fume, ASTM C1240, present in a blended cement.

<sup>(10)</sup> Fly ash or other pozzolans and silica fume shall constitute no more than 25 and 10 percent, respectively, of the total weight of the cementitious materials.

<sup>(11)</sup> Prescriptive limits shown may be waived for concrete mixes that demonstrate excellent freeze/thaw durability in a detailed and current testing program.

## Redi-Rock 41" (1030 mm) wide, 9" (230 mm) Setback Retaining Blocks

### DESIGN PROPERTIES

HORIZONTAL SETBACK / WALL FACE BATTER OPTIONS		BLOCK TO BLOCK INTERFACE SHEAR <sup>(13)</sup>
10 inch (254 mm) KNOB	1 5/8 inch (41 mm) PER BLOCK COURSE (5.2° BATTER)	$V = 6,061 + N \tan 44^\circ \leq 11,276 \text{ lb/ft} (88.4 + N \tan 44^\circ \leq 164.5 \text{ kN/m})$
7 1/2 inch (190 mm) KNOB	3/8 inch (10 mm) PER BLOCK COURSE (1.2° BATTER)	$V = 1,178 + N \tan 54^\circ \leq 10,970 \text{ lb/ft} (17.2 + N \tan 54^\circ \leq 160.1 \text{ kN/m})$
6 3/4 inch (171 mm) KNOB	NO SETBACK (NO BATTER) <sup>(12)</sup>	$V = 1,178 + N \tan 54^\circ \leq 10,970 \text{ lb/ft} (17.2 + N \tan 54^\circ \leq 160.1 \text{ kN/m})$
LIMESTONE / COBBLESTONE BLOCKS		128 lb/ft <sup>3</sup> (2082 kN/m <sup>3</sup> )
LEDGESTONE BLOCKS		125 lb/ft <sup>3</sup> (2018 kN/m <sup>3</sup> )
MINIMUM CONSTRUCTION RADIUS <sup>(15)</sup>		
CONCAVE CURVE		14 ft 6 in (4.42 m)
CONVEX CURVE		14 ft 6 in (4.42 m)

<sup>(12)</sup> Special consideration should be given to the design of vertical retaining walls subject to active lateral earth pressure.

<sup>(13)</sup> Values based on full scale testing performed in October 2011. Copies of the full test reports are available at [www.redi-rock.com](http://www.redi-rock.com).

<sup>(14)</sup> The infilled unit weights shown here are based on an assumed concrete unit weight of 143 lb/ft<sup>3</sup> (2291 kg/m<sup>3</sup>) and an assumed soil unit weight of 100 lb/ft<sup>3</sup> (1602 kg/m<sup>3</sup>). They are reference values. Several factors can cause the unit weights of both concrete and infill soil to vary. The designer should use sound engineering judgement when assigning an infilled unit weight value for analysis.

<sup>(15)</sup> The minimum construction radius stated is applicable to both concave and convex curved retaining wall sections. Increases to this minimum radius are required to account for wall batter. Special consideration should be given to block selection, facing batter, and wall height when selecting the minimum radius for the final wall alignment.

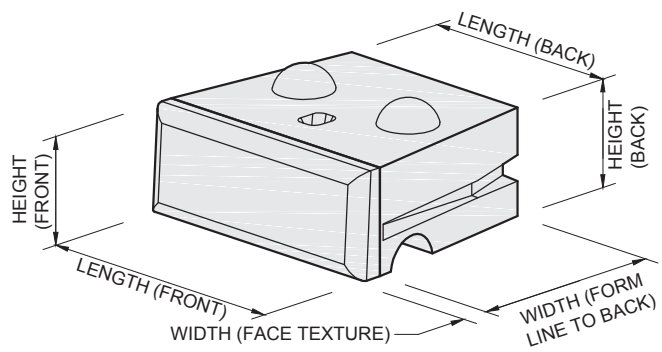

MIDDLE

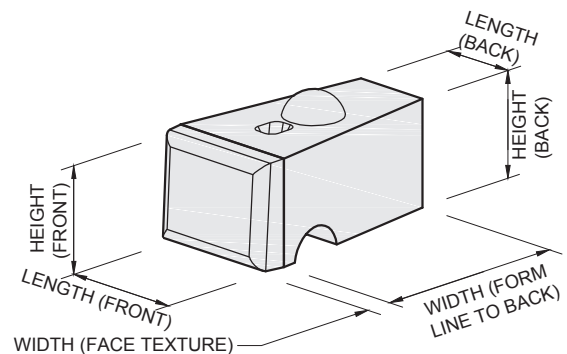

HALF MIDDLE

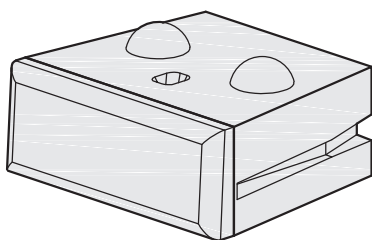

BOTTOM

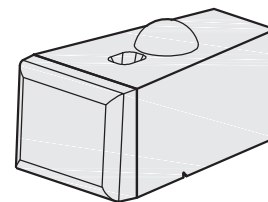

HALF BOTTOM

## Redi-Rock 60" (1520 mm) wide, 9" (230 mm) Setback Retaining Blocks

The Redi-Rock 60" (1520mm) Retaining wall blocks are machine-placed, wet-cast, precast modular block units manufactured from first-purpose, non-reconstituted concrete and intended for constructing dry-stacked modular retaining wall systems. The block units are manufactured from structural-grade concrete mixes in accordance with ASTM C94 or ASTM C685 that produce a finished unit with excellent resistance to freeze-thaw, deicing chemical exposure, and submerged conditions in both fresh water and salt water applications. All Redi-Rock Retaining wall products are manufactured and distributed through an international network of individually-owned, licensed precast concrete manufacturers.

### DIMENSIONAL PROPERTIES

DIMENSIONS <sup>(1)</sup>	MIDDLE	BOTTOM	HALF MIDDLE	HALF BOTTOM
HEIGHT (FRONT OF BLOCK)	18 ± 3/16 (457 ± 5)	18 ± 3/16 (457 ± 5)	18 ± 3/16 (457 ± 5)	18 ± 3/16 (457 ± 5)
HEIGHT (BACK OF BLOCK)	18 ± 3/16 (457 ± 5)	18 ± 3/16 (457 ± 5)	18 ± 3/16 (457 ± 5)	18 ± 3/16 (457 ± 5)
LENGTH (FRONT OF BLOCK)	46 1/8 ± 1/2 (1172 ± 13)		22 13/16 ± 1/4 (579 ± 6)	
LENGTH (BACK OF BLOCK)	31 3/8 ± 1/2 (797 ± 13)		8 3/8 ± 1/4 (231 ± 6)	
WIDTH	54 5/8 ± 1/2 (1387 ± 13) PLUS ± 5 3/8 (136) FACE TEXTURE		54 5/8 ± 1/2 (1387 ± 13) PLUS ± 5 3/8 (136) FACE TEXTURE	
CONCRETE VOLUME	MIDDLE	BOTTOM	HALF MIDDLE	HALF BOTTOM
LIMESTONE/COBBLESTONE FACE	± 23.06 ft <sup>3</sup> (0.653 m <sup>3</sup> )	± 23.97 ft <sup>3</sup> (0.677 m <sup>3</sup> )	± 9.37 ft <sup>3</sup> (0.264 m <sup>3</sup> )	± 9.80 ft <sup>3</sup> (0.276 m <sup>3</sup> )
LEDGESTONE FACE	± 22.56 ft <sup>3</sup> (0.639 m <sup>3</sup> )	± 23.47 ft <sup>3</sup> (0.665 m <sup>3</sup> )	± 9.12 ft <sup>3</sup> (0.258 m <sup>3</sup> )	± 9.55 ft <sup>3</sup> (0.270 m <sup>3</sup> )
SHIPPING/HANDLING WEIGHT <sup>(2)</sup>	MIDDLE	BOTTOM	HALF MIDDLE	HALF BOTTOM
LIMESTONE/COBBLESTONE FACE	± 3297 lb (1495 kg)	± 3428 lb (1554 kg)	± 1340 lb (608 kg)	± 1401 lb (635 kg)
LEDGESTONE FACE	± 3226 lb (1463 kg)	± 3356 lb (1522 kg)	± 1305 lb (592 kg)	± 1366 lb (620 kg)

<sup>(1)</sup> All dimensions are inches (mm).

<sup>(2)</sup> Weight shown is based on an assumed concrete unit weight of 143 lb/ft<sup>3</sup> (2291 kg/m<sup>3</sup>). Actual weights will vary.

### CONCRETE MIX PROPERTIES <sup>(3)</sup>

FREEZE THAW EXPOSURE CLASS <sup>(4)</sup>	MINIMUM 28 DAY COMPRESSIVE STRENGTH <sup>(5)</sup>	MAXIMUM WATER CEMENT RATIO	NOMINAL MAXIMUM AGGREGATE SIZE	AGGREGATE CLASS DESIGNATION <sup>(6)</sup>	AIR CONTENT <sup>(7)</sup>
MODERATE	4,000 psi (27.6 MPa)	0.45	1 inch (25 mm)	3M	4.5% ± 1.5%
SEVERE	4,000 psi (27.6 MPa)	0.45	1 inch (25 mm)	3S	6.0% ± 1.5%
VERY SEVERE	4,500 psi (30.0 MPa)	0.40	1 inch (25 mm)	4S	6.0% ± 1.5%
MAXIMUM WATER-SOLUBLE CHLORIDE ION (Cl <sup>-</sup> ) CONTENT IN CONCRETE, PERCENT BY WEIGHT OF CEMENT <sup>(8)</sup>					0.015
MAXIMUM CHLORIDE AS Cl <sup>-</sup> CONCENTRATION IN MIXING WATER, PARTS PER MILLION					1000
MAXIMUM PERCENTAGE OF TOTAL CEMENTITIOUS MATERIALS BY WEIGHT <sup>(9, 11)</sup> (VERY SEVERE EXPOSURE CLASS ONLY)					
FLY ASH OR OTHER POZZOLANS CONFORMING TO ASTM C618					25
SLAG CONFORMING TO ASTM C989					50
SILICA FUME CONFORMING TO ASTM C1240					10
TOTAL OF FLY ASH OR OTHER POZZOLANS, SLAG, AND SILICA FUME <sup>(10)</sup>					50
TOTAL OF FLY ASH OR OTHER POZZOLANS AND SILICA FUME <sup>(10)</sup>					35
ALKALI-AGGREGATE REACTIVITY MITIGATION PER ACI 201					

<sup>(3)</sup> Concrete mix properties are in general accordance with ACI 318 durability requirements. Research has shown that concrete manufactured to these standards demonstrates good durability and performance. When these requirements are followed, specific freeze-thaw testing of the concrete is typically NOT required.

<sup>(4)</sup> Exposure class is as described in ACI 318. "MODERATE" describes concrete that is exposed to freezing and thawing cycles and occasional exposure to moisture. "SEVERE" describes concrete that is exposed to freezing and thawing cycles and in continuous contact with moisture. "VERY SEVERE" describes concrete that is exposed to freezing and thawing cycles and in continuous contact with moisture and exposed to deicing chemicals. Exposure class should be specified by owner/purchaser prior to order placement. Longer lead times may be required for block units manufactured for "severe" and "very severe" exposure classes.

<sup>(5)</sup> Test method ASTM C39.

<sup>(6)</sup> Defined in ASTM C33 Table 3 *Limits for Deleterious Substances and Physical Property Requirements of Coarse Aggregate for Concrete*.

<sup>(7)</sup> Test method ASTM C231.

<sup>(8)</sup> Test method ASTM C1218 at age between 28 and 42 days.

<sup>(9)</sup> The total cementitious material also includes ASTM C150, C595, C845, and C1157 cement. The maximum percentages shall include:

- (a) Fly ash or other pozzolans in type IP, blended cement, ASTM C595, or ASTM C1157.
- (b) Slag used in the manufacture of an IS blended cement, ASTM C595, or ASTM C1157.
- (c) Silica fume, ASTM C1240, present in a blended cement.

<sup>(10)</sup> Fly ash or other pozzolans and silica fume shall constitute no more than 25 and 10 percent, respectively, of the total weight of the cementitious materials.

<sup>(11)</sup> Prescriptive limits shown may be waived for concrete mixes that demonstrate excellent freeze/thaw durability in a detailed and current testing program.

## Redi-Rock 60" (1520 mm) wide, 9" (230 mm) Setback Retaining Blocks

### DESIGN PROPERTIES

HORIZONTAL SETBACK / WALL FACE BATTER OPTIONS		BLOCK TO BLOCK INTERFACE SHEAR <sup>(13)</sup>
10 inch (254 mm) KNOB	1 5/8 inch (41 mm) PER BLOCK COURSE (5.2° BATTER)	$V = 6,061 + N \tan 44^\circ \leq 11,276 \text{ lb/ft} (88.4 + N \tan 44^\circ \leq 164.5 \text{ kN/m})$
7 1/2 inch (190 mm) KNOB	3/8 inch (10 mm) PER BLOCK COURSE (1.2° BATTER)	$V = 1,178 + N \tan 54^\circ \leq 10,970 \text{ lb/ft} (17.2 + N \tan 54^\circ \leq 160.1 \text{ kN/m})$
6 3/4 inch (171 mm) KNOB	NO SETBACK (NO BATTER) <sup>(12)</sup>	$V = 1,178 + N \tan 54^\circ \leq 10,970 \text{ lb/ft} (17.2 + N \tan 54^\circ \leq 160.1 \text{ kN/m})$
INFILLED UNIT WEIGHT FOR WALL STABILITY CALCULATIONS <sup>(14)</sup>		
60" (1520) BOTTOM RETAINING UNIT		60" (1520) MIDDLE RETAINING UNIT
LIMESTONE / COBBLESTONE BLOCKS		135 lb/ft <sup>3</sup> (2146 kg/m <sup>3</sup> )
LEDGESTONE BLOCKS		132 lb/ft <sup>3</sup> (2114 kg/m <sup>3</sup> )
128 lb/ft <sup>3</sup> (2050 kg/m <sup>3</sup> )		
MINIMUM CONSTRUCTION RADIUS <sup>(15)</sup>		
CONCAVE CURVE		14 ft 6 in (4.42 m)
CONVEX CURVE		14 ft 6 in (4.42 m)

<sup>(12)</sup> Special consideration should be given to the design of vertical retaining walls subject to active lateral earth pressure.

<sup>(13)</sup> Values based on full scale testing performed in October 2011. Copies of the full test reports are available at [www.redi-rock.com](http://www.redi-rock.com).

<sup>(14)</sup> The infilled unit weights shown here are based on full width units and an assumed concrete unit weight of 143 lb/ft<sup>3</sup> (2291 kg/m<sup>3</sup>) and an assumed soil unit weight of 100 lb/ft<sup>3</sup> (1602 kg/m<sup>3</sup>). They are reference values. Several factors can cause the unit weights of both concrete and infill soil to vary. The designer should use sound engineering judgement when assigning an infilled unit weight value for analysis.

<sup>(15)</sup> The minimum construction radius stated is applicable to both concave and convex curved retaining wall sections. Increases to this minimum radius are required to account for wall batter. Special consideration should be given to block selection, facing batter, and wall height when selecting the minimum radius for the final wall alignment.

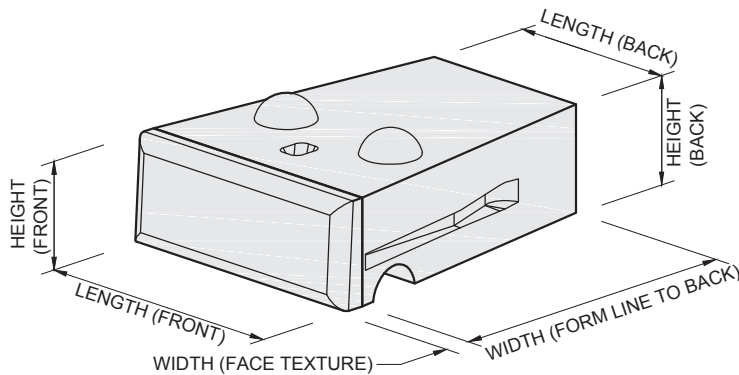

MIDDLE - 60" (1520)

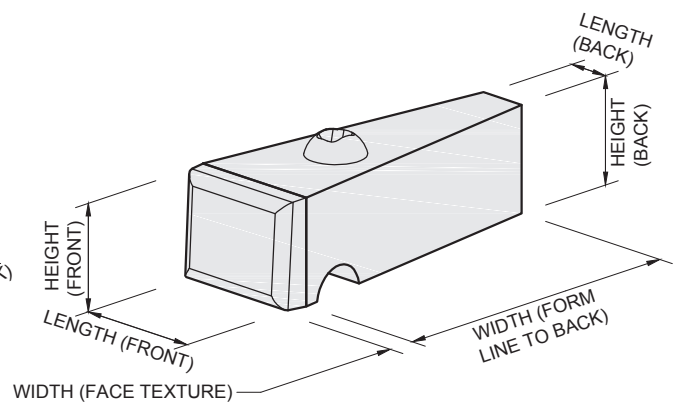

HALF MIDDLE - 60" (1520)

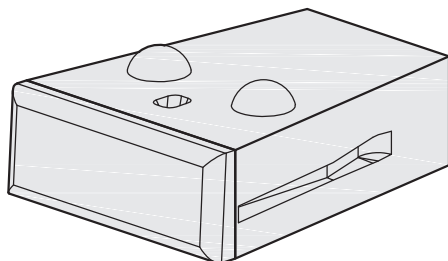

BOTTOM - 60" (1520)

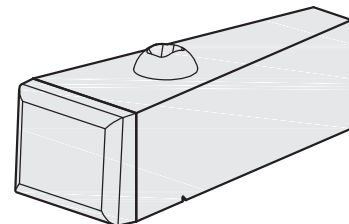

HALF BOTTOM - 60" (1520)

Revised 032315

## Redi-Rock 28" (710 mm) & 41" (1030 mm) Positive Connection (PC) Retaining Blocks

The Redi-Rock 28" (710mm) & 41" (1030mm) Positive Connection retaining wall blocks are machine-placed, wet-cast, precast modular block units manufactured from first-purpose, non-reconstituted concrete and intended for constructing dry-stacked modular retaining wall systems. The block units are manufactured from structural-grade concrete mixes in accordance with ASTM C94 or ASTM C685 that produce a finished unit with excellent resistance to freeze-thaw, deicing chemical exposure, and submerged conditions in both fresh water and salt water applications. All Redi-Rock Retaining wall products are manufactured and distributed through an international network of individually-owned, licensed precast concrete manufacturers.

### DIMENSIONAL PROPERTIES

DIMENSIONS <sup>(1)</sup>	TOP - 28" (710)	MIDDLE - 28" (710)	BOTTOM - 28" (710)	TOP - 41" (1030)	MIDDLE - 41" (1030)	BOTTOM - 41" (1030)
HEIGHT (FRONT OF BLOCK)	18 ± 3/16 (457 ± 5)	18 ± 3/16 (457 ± 5)	18 ± 3/16 (457 ± 5)	18 ± 3/16 (457 ± 5)	18 ± 3/16 (457 ± 5)	18 ± 3/16 (457 ± 5)
HEIGHT (BACK OF BLOCK)	13 ± 3/16 (330 ± 5)	18 ± 3/16 (457 ± 5)	18 ± 3/16 (457 ± 5)	13 ± 3/16 (330 ± 5)	18 ± 3/16 (457 ± 5)	18 ± 3/16 (457 ± 5)
LENGTH (FRONT OF BLOCK)	46 1/8 ± 1/2 (1172 ± 13)			46 1/8 ± 1/2 (1172 ± 13)		
LENGTH (BACK OF BLOCK)	40 ± 1/2 (1016 ± 13)			36 5/8" ± 1/2 (930 ± 13)		
WIDTH	22 5/8 ± 1/2 (575 ± 13) PLUS ± 5 3/8 (136) FACE TEXTURE			35 1/8 ± 1/2 (892 ± 13) PLUS ± 5 3/8 (136) FACE TEXTURE		
CONCRETE VOLUME	TOP - 28" (710)	MIDDLE - 28" (710)	BOTTOM - 28" (710)	TOP - 41" (1030)	MIDDLE - 41" (1030)	BOTTOM - 41" (1030)
LIMESTONE/COBBLESTONE FACE	±8.16 ft <sup>3</sup> (0.231 m <sup>3</sup> )	±10.62 ft <sup>3</sup> (0.301 m <sup>3</sup> )	±11.34 ft <sup>3</sup> (0.321 m <sup>3</sup> )	±11.38 ft <sup>3</sup> (0.322 m <sup>3</sup> )	±15.19 ft <sup>3</sup> (0.430 m <sup>3</sup> )	±15.92 ft <sup>3</sup> (0.451 m <sup>3</sup> )
LEDGESTONE FACE	±7.67 ft <sup>3</sup> (0.217 m <sup>3</sup> )	±10.12 ft <sup>3</sup> (0.287 m <sup>3</sup> )	±10.85 ft <sup>3</sup> (0.307 m <sup>3</sup> )	±10.88 ft <sup>3</sup> (0.308 m <sup>3</sup> )	±14.69 ft <sup>3</sup> (0.416 m <sup>3</sup> )	±15.42 ft <sup>3</sup> (0.437 m <sup>3</sup> )
SHIPPING/HANDLING WEIGHT <sup>(2)</sup>	TOP - 28" (710)	MIDDLE - 28" (710)	BOTTOM - 28" (710)	TOP - 41" (1030)	MIDDLE - 41" (1030)	BOTTOM - 41" (1030)
LIMESTONE/COBBLESTONE FACE	± 1167 lb (529 kg)	± 1518 lb (689 kg)	± 1622 lb (736 kg)	± 1627 lb (738 kg)	±2172 lb (985 kg)	± 2276 lb (1032 kg)
LEDGESTONE FACE	± 1096 lb (497 kg)	± 1447 lb (656 kg)	± 1551 lb (703 kg)	± 1556 lb (706 kg)	± 2101 lb (953 kg)	± 2205 lb (1000 kg)

<sup>(1)</sup> All dimensions are inches (mm).

<sup>(2)</sup> Weight shown is based on an assumed concrete unit weight of 143 lb/ft<sup>3</sup> (2291 kg/m<sup>3</sup>). Actual weights will vary.

### CONCRETE MIX PROPERTIES <sup>(3)</sup>

FREEZE THAW EXPOSURE CLASS <sup>(4)</sup>	MINIMUM 28 DAY COMPRESSIVE STRENGTH <sup>(5)</sup>	MAXIMUM WATER CEMENT RATIO	NOMINAL MAXIMUM AGGREGATE SIZE	AGGREGATE CLASS DESIGNATION <sup>(6)</sup>	AIR CONTENT <sup>(7)</sup>
MODERATE	4,000 psi (27.6 MPa)	0.45	1 inch (25 mm)	3M	4.5% ± 1.5%
SEVERE	4,000 psi (27.6 MPa)	0.45	1 inch (25 mm)	3S	6.0% ± 1.5%
VERY SEVERE	4,500 psi (30.0 MPa)	0.40	1 inch (25 mm)	4S	6.0% ± 1.5%
MAXIMUM WATER-SOLUBLE CHLORIDE ION (Cl <sup>-</sup> ) CONTENT IN CONCRETE, PERCENT BY WEIGHT OF CEMENT <sup>(8)</sup>					0.015
MAXIMUM CHLORIDE AS Cl <sup>-</sup> CONCENTRATION IN MIXING WATER, PARTS PER MILLION					1000
MAXIMUM PERCENTAGE OF TOTAL CEMENTITIOUS MATERIALS BY WEIGHT <sup>(9, 11)</sup> (VERY SEVERE EXPOSURE CLASS ONLY)					
FLY ASH OR OTHER POZZOLANS CONFORMING TO ASTM C618					25
SLAG CONFORMING TO ASTM C989					50
SILICA FUME CONFORMING TO ASTM C1240					10
TOTAL OF FLY ASH OR OTHER POZZOLANS, SLAG, AND SILICA FUME <sup>(10)</sup>					50
TOTAL OF FLY ASH OR OTHER POZZOLANS AND SILICA FUME <sup>(10)</sup>					35
ALKALI-AGGREGATE REACTIVITY MITIGATION PER ACI 201					

<sup>(3)</sup> Concrete mix properties are in general accordance with ACI 318 durability requirements. Research has shown that concrete manufactured to these standards demonstrates good durability and performance. When these requirements are followed, specific freeze-thaw testing of the concrete is typically NOT required.

<sup>(4)</sup> Exposure class is as described in ACI 318. "MODERATE" describes concrete that is exposed to freezing and thawing cycles and occasional exposure to moisture. "SEVERE" describes concrete that is exposed to freezing and thawing cycles and in continuous contact with moisture. "VERY SEVERE" describes concrete that is exposed to freezing and thawing cycles and in continuous contact with moisture and exposed to deicing chemicals. Exposure class should be specified by owner/purchaser prior to order placement. Longer lead times may be required for block units manufactured for "severe" and "very severe" exposure classes.

<sup>(5)</sup> Test method ASTM C39.

<sup>(6)</sup> Defined in ASTM C33 Table 3 *Limits for Deleterious Substances and Physical Property Requirements of Coarse Aggregate for Concrete*.

<sup>(7)</sup> Test method ASTM C231.

<sup>(8)</sup> Test method ASTM C1218 at age between 28 and 42 days.

<sup>(9)</sup> The total cementitious material also includes ASTM C150, C595, C845, and C1157 cement. The maximum percentages shall include:

- (a) Fly ash or other pozzolans in type IP, blended cement, ASTM C595, or ASTM C1157.
- (b) Slag used in the manufacture of an IS blended cement, ASTM C595, or ASTM C1157.
- (c) Silica fume, ASTM C1240, present in a blended cement.

<sup>(10)</sup> Fly ash or other pozzolans and silica fume shall constitute no more than 25 and 10 percent, respectively, of the total weight of the cementitious materials.

<sup>(11)</sup> Prescriptive limits shown may be waived for concrete mixes that demonstrate excellent freeze/thaw durability in a detailed and current testing program.

**Redi-Rock 28" (710 mm) & 41" (1030 mm) Positive Connection (PC) Retaining Blocks**

**DESIGN PROPERTIES**

HORIZONTAL SETBACK / WALL FACE BATTER OPTIONS		BLOCK TO BLOCK INTERFACE SHEAR <sup>(13)</sup>
10 inch (254 mm) KNOB	1 5/8 inch (41 mm) PER BLOCK COURSE (5.2° BATTER)	$V = 6,061 + N \tan 44^\circ \leq 11,276 \text{ lb/ft}$ ( $88.4 + N \tan 44^\circ \leq 164.5 \text{ kN/m}$ )
7 1/2 inch (190 mm) KNOB	3/8 inch (10 mm) PER BLOCK COURSE (1.2° BATTER)	$V = 1,178 + N \tan 54^\circ \leq 10,970 \text{ lb/ft}$ ( $17.2 + N \tan 54^\circ \leq 160.1 \text{ kN/m}$ )
6 3/4 inch (171 mm) KNOB	NO SETBACK (NO BATTER) <sup>(12)</sup>	$V = 1,178 + N \tan 54^\circ \leq 10,970 \text{ lb/ft}$ ( $17.2 + N \tan 54^\circ \leq 160.1 \text{ kN/m}$ )
INFILLED UNIT WEIGHT FOR WALL STABILITY CALCULATIONS <sup>(14)</sup>		
LIMESTONE / COBBLESTONE BLOCKS		28" (710) POSITIVE CONNECTION UNIT      41" (1030) POSITIVE CONNECTION UNIT
		125 lb/ft <sup>3</sup> (2000 kg/m <sup>3</sup> )      126 lb/ft <sup>3</sup> (2018 kg/m <sup>3</sup> )
LEDGESTONE BLOCKS		120 lb/ft <sup>3</sup> (1921 kg/m <sup>3</sup> )      123 lb/ft <sup>3</sup> (1970 kg/m <sup>3</sup> )
MINIMUM CONSTRUCTION RADIUS <sup>(15)</sup>		
CONCAVE CURVE		14 ft 6 in (4.42 m)
CONVEX CURVE		14 ft 6 in (4.42 m)

<sup>(12)</sup> Special consideration should be given to the design of vertical retaining walls subject to active lateral earth pressure.

<sup>(13)</sup> Values based on full scale testing performed in October 2011. Copies of the full test reports are available at [www.redi-rock.com](http://www.redi-rock.com).

<sup>(14)</sup> The infilled unit weights shown here are based on an assumed concrete unit weight of 143 lb/ft<sup>3</sup> (2291 kg/m<sup>3</sup>) and an assumed soil unit weight of 100 lb/ft<sup>3</sup> (1602 kg/m<sup>3</sup>). They are reference values. Several factors can cause the unit weights of both concrete and infill soil to vary. The designer should use sound engineering judgement when assigning an infilled unit weight value for analysis.

<sup>(15)</sup> The minimum construction radius stated is applicable to both concave and convex curved retaining wall sections. Increases to this minimum radius are required to account for wall batter. Special consideration should be given to block selection, facing batter, and wall height when selecting the minimum radius for the final wall alignment.

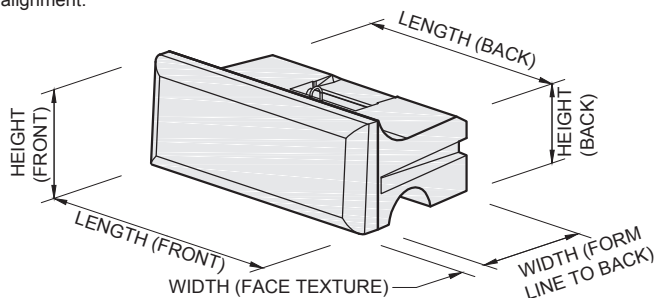

28" (710 mm) TOP

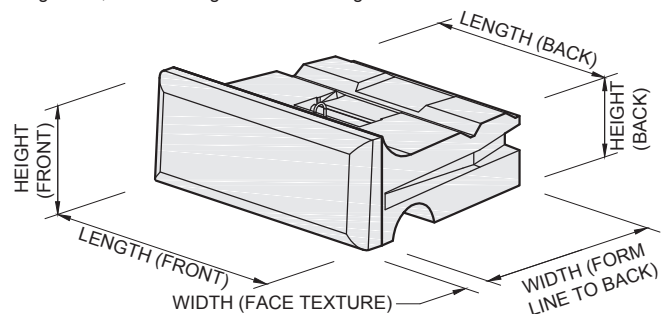

41" (1030 mm) TOP

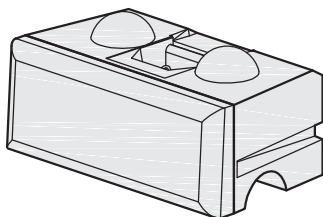

28" (710 mm) MIDDLE

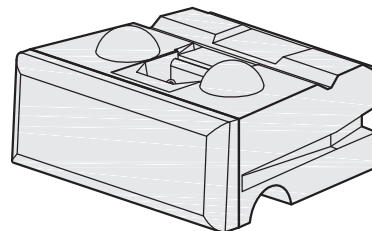

41" (1030 mm) MIDDLE

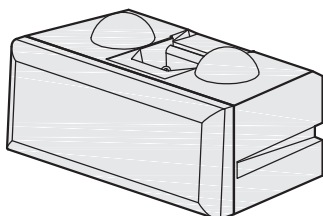

28" (710 mm) BOTTOM

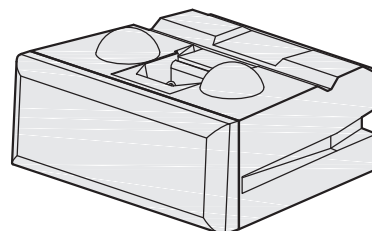

41" (1030 mm) BOTTOM

Revised 032315

## Redi-Rock Freestanding Straight Blocks

The Redi-Rock Freestanding wall units are machine-placed, wet-cast, precast modular block units manufactured from first-purpose, non-reconstituted concrete and intended to be used exclusively or in combination with dry-stacked modular retaining wall blocks. These units are manufactured from structural-grade concrete mixes in accordance with ASTM C94 or ASTM C685 that produce a finished unit with excellent resistance to freeze-thaw, deicing chemical exposure, and submerged conditions in both fresh water and salt water applications. All Redi-Rock products are manufactured and distributed through an international network of individually-owned, licensed precast concrete manufacturers.

### DIMENSIONAL PROPERTIES

DIMENSIONS <sup>(1)</sup>				
HEIGHT: 18 ± 3/16 (457 ± 5)	LENGTH: 46 1/8 ± 1/2 (1172 ± 13)		WIDTH: ± 24 (610) LEDGESTONE / COBBLESTONE, ± 23 (584) LIMESTONE	
CONCRETE VOLUME	BOTTOM	MIDDLE	TOP	GARDEN TOP
LIMESTONE/COBBLESTONE FACE	±10.65 ft <sup>3</sup> (0.302 m <sup>3</sup> )	±9.84 ft <sup>3</sup> (0.279 m <sup>3</sup> )	±9.61 ft <sup>3</sup> (0.272 m <sup>3</sup> )	±7.35 ft <sup>3</sup> (0.208 m <sup>3</sup> )
LEDGESTONE FACE	±9.66 ft <sup>3</sup> (0.273 m <sup>3</sup> )	±8.84 ft <sup>3</sup> (0.250 m <sup>3</sup> )	±8.62 ft <sup>3</sup> (0.244 m <sup>3</sup> )	±6.35 ft <sup>3</sup> (0.180 m <sup>3</sup> )
SHIPPING/HANDLING WEIGHT <sup>(2)</sup>	BOTTOM	MIDDLE	TOP	GARDEN TOP
LIMESTONE/COBBLESTONE FACE	± 1523 lb (691 kg)	± 1407 lb (638 kg)	± 1375 lb (623 kg)	± 1050 lb (476 kg)
LEDGESTONE FACE	± 1381 lb (626 kg)	± 1264 lb (573 kg)	± 1232 lb (559 kg)	± 908 lb (412 kg)

<sup>(1)</sup> All dimensions are inches (mm).

<sup>(2)</sup> Weight shown is based on an assumed concrete unit weight of 143 lb/ft<sup>3</sup> (2291 kg/m<sup>3</sup>). Actual weights will vary.

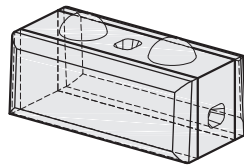

BOTTOM

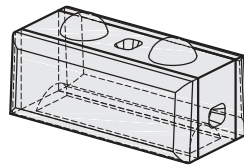

MIDDLE

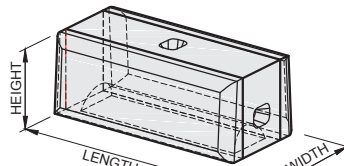

TOP

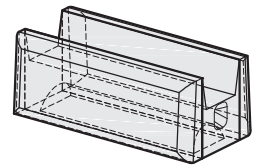

GARDEN TOP

### CONCRETE MIX PROPERTIES <sup>(2)</sup>

FREEZE THAW EXPOSURE CLASS <sup>(4)</sup>	MINIMUM 28 DAY COMPRESSIVE STRENGTH <sup>(5)</sup>	MAXIMUM WATER CEMENT RATIO	NOMINAL MAXIMUM AGGREGATE SIZE	AGGREGATE CLASS DESIGNATION <sup>(6)</sup>	AIR CONTENT <sup>(7)</sup>
MODERATE	4,000 psi (27.6 MPa)	0.45	1 inch (25 mm)	3M	4.5% ± 1.5%
SEVERE	4,000 psi (27.6 MPa)	0.45	1 inch (25 mm)	3S	6.0% ± 1.5%
VERY SEVERE	4,500 psi (30.0 MPa)	0.40	1 inch (25 mm)	4S	6.0% ± 1.5%
MAXIMUM WATER-SOLUBLE CHLORIDE ION (Cl <sup>-</sup> ) CONTENT IN CONCRETE, PERCENT BY WEIGHT OF CEMENT <sup>(8)</sup>					0.015
MAXIMUM CHLORIDE AS Cl <sup>-</sup> CONCENTRATION IN MIXING WATER, PARTS PER MILLION					1000
MAXIMUM PERCENTAGE OF TOTAL CEMENTITIOUS MATERIALS BY WEIGHT <sup>(9)</sup> (VERY SEVERE EXPOSURE CLASS ONLY)					
FLY ASH OR OTHER POZZOLANS CONFORMING TO ASTM C618					25
SLAG CONFORMING TO ASTM C989					50
SILICA FUME CONFORMING TO ASTM C1240					10
TOTAL OF FLY ASH OR OTHER POZZOLANS, SLAG, AND SILICA FUME <sup>(10)</sup>					50
TOTAL OF FLY ASH OR OTHER POZZOLANS AND SILICA FUME <sup>(10)</sup>					35

<sup>(3)</sup> Concrete mix properties are in general accordance with ACI 318 durability requirements. Research has shown that concrete manufactured to these standards demonstrates good durability and performance. When these requirements are followed, specific freeze-thaw testing of the concrete is typically NOT required.

<sup>(4)</sup> Exposure class is as described in ACI 318. "MODERATE" describes concrete that is exposed to freezing and thawing cycles and occasional exposure to moisture. "SEVERE" describes concrete that is exposed to freezing and thawing cycles and in continuous contact with moisture. "VERY SEVERE" describes concrete that is exposed to freezing and thawing cycles and in continuous contact with moisture and exposed to deicing chemicals. Exposure class should be specified by owner/purchaser prior to order placement. Longer lead times may be required for block units manufactured for "severe" and "very severe" exposure classes.

<sup>(5)</sup> Test method ASTM C39.

<sup>(6)</sup> Defined in ASTM C33 Table 3 *Limits for Deleterious Substances and Physical Property Requirements of Coarse Aggregate for Concrete*.

<sup>(7)</sup> Test method ASTM C231.

<sup>(8)</sup> Test method ASTM C1218 at age between 28 and 42 days.

<sup>(9)</sup> The total cementitious material also includes ASTM C150, C595, C845, and C1157 cement. The maximum percentages shall include:

- (a) Fly ash or other pozzolans in type IP, blended cement, ASTM C595, or ASTM C1157.
- (b) Slag used in the manufacture of an IS blended cement, ASTM C595, or ASTM C1157.
- (c) Silica fume, ASTM C1240, present in a blended cement.

<sup>(10)</sup> Fly ash or other pozzolans and silica fume shall constitute no more than 25 and 10 percent, respectively, of the total weight of the cementitious materials.

## Redi-Rock Freestanding Variable Radius Blocks

The Redi-Rock Freestanding wall units are machine-placed, wet-cast, precast modular block units manufactured from first-purpose, non-reconstituted concrete and intended to be used exclusively or in combination with dry-stacked modular retaining wall blocks. These units are manufactured from structural-grade concrete mixes in accordance with ASTM C94 or ASTM C685 that produce a finished unit with excellent resistance to freeze-thaw, deicing chemical exposure, and submerged conditions in both fresh water and salt water applications. All Redi-Rock products are manufactured and distributed through an international network of individually-owned, licensed precast concrete manufacturers.

### DIMENSIONAL PROPERTIES

DIMENSIONS <sup>(1)</sup>				
HEIGHT: 18 ± 3/16 (457 ± 5)	LENGTH: 46 1/8 ± 1/2 (1172 ± 13)		WIDTH: ± 24 (610) LEDGESTONE / COBBLESTONE, ± 23 (584) LIMESTONE	
CONCRETE VOLUME	BOTTOM	MIDDLE	TOP	GARDEN TOP
LIMESTONE/COBBLESTONE FACE	±9.65 ft <sup>3</sup> (0.273 m <sup>3</sup> )	±8.86 ft <sup>3</sup> (0.251 m <sup>3</sup> )	±8.63 ft <sup>3</sup> (0.244 m <sup>3</sup> )	±6.76 ft <sup>3</sup> (0.191 m <sup>3</sup> )
LEDGESTONE FACE	±8.66 ft <sup>3</sup> (0.245 m <sup>3</sup> )	±7.86 ft <sup>3</sup> (0.223 m <sup>3</sup> )	±7.64 ft <sup>3</sup> (0.216 m <sup>3</sup> )	±5.76 ft <sup>3</sup> (0.163 m <sup>3</sup> )
SHIPPING/HANDLING WEIGHT <sup>(2)</sup>	BOTTOM	MIDDLE	TOP	GARDEN TOP
LIMESTONE/COBBLESTONE FACE	± 1380 lb (626 kg)	± 1267 lb (574 kg)	± 1235 lb (560 kg)	± 967 lb (438 kg)
LEDGESTONE FACE	± 1238 lb (561 kg)	± 1124 lb (510 kg)	± 1092 lb (495 kg)	± 824 lb (374 kg)

<sup>(1)</sup> All dimensions are inches (mm).

<sup>(2)</sup> Weight shown is based on an assumed concrete unit weight of 143 lb/ft<sup>3</sup> (2291 kg/m<sup>3</sup>). Actual weights will vary.

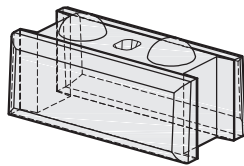

BOTTOM

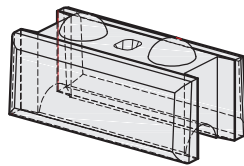

MIDDLE

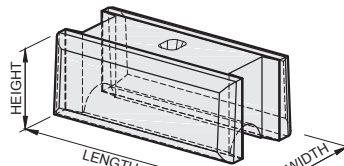

TOP

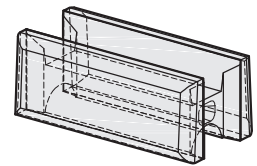

GARDEN TOP

### CONCRETE MIX PROPERTIES <sup>(2)</sup>

FREEZE THAW EXPOSURE CLASS <sup>(4)</sup>	MINIMUM 28 DAY COMPRESSIVE STRENGTH <sup>(5)</sup>	MAXIMUM WATER CEMENT RATIO	NOMINAL MAXIMUM AGGREGATE SIZE	AGGREGATE CLASS DESIGNATION <sup>(6)</sup>	AIR CONTENT <sup>(7)</sup>
MODERATE	4,000 psi (27.6 MPa)	0.45	1 inch (25 mm)	3M	4.5% ± 1.5%
SEVERE	4,000 psi (27.6 MPa)	0.45	1 inch (25 mm)	3S	6.0% ± 1.5%
VERY SEVERE	4,500 psi (30.0 MPa)	0.40	1 inch (25 mm)	4S	6.0% ± 1.5%
MAXIMUM WATER-SOLUBLE CHLORIDE ION (Cl <sup>-</sup> ) CONTENT IN CONCRETE, PERCENT BY WEIGHT OF CEMENT <sup>(8)</sup>					0.015
MAXIMUM CHLORIDE AS Cl <sup>-</sup> CONCENTRATION IN MIXING WATER, PARTS PER MILLION					1000
MAXIMUM PERCENTAGE OF TOTAL CEMENTITIOUS MATERIALS BY WEIGHT <sup>(9)</sup> (VERY SEVERE EXPOSURE CLASS ONLY)					
FLY ASH OR OTHER POZZOLANS CONFORMING TO ASTM C618					25
SLAG CONFORMING TO ASTM C989					50
SILICA FUME CONFORMING TO ASTM C1240					10
TOTAL OF FLY ASH OR OTHER POZZOLANS, SLAG, AND SILICA FUME <sup>(10)</sup>					50
TOTAL OF FLY ASH OR OTHER POZZOLANS AND SILICA FUME <sup>(10)</sup>					35

<sup>(3)</sup> Concrete mix properties are in general accordance with ACI 318 durability requirements. Research has shown that concrete manufactured to these standards demonstrates good durability and performance. When these requirements are followed, specific freeze-thaw testing of the concrete is typically NOT required.

<sup>(4)</sup> Exposure class is as described in ACI 318. "MODERATE" describes concrete that is exposed to freezing and thawing cycles and occasional exposure to moisture. "SEVERE" describes concrete that is exposed to freezing and thawing cycles and in continuous contact with moisture. "VERY SEVERE" describes concrete that is exposed to freezing and thawing cycles and in continuous contact with moisture and exposed to deicing chemicals. Exposure class should be specified by owner/purchaser prior to order placement. Longer lead times may be required for block units manufactured for "severe" and "very severe" exposure classes.

<sup>(5)</sup> Test method ASTM C39.

<sup>(6)</sup> Defined in ASTM C33 Table 3 *Limits for Deleterious Substances and Physical Property Requirements of Coarse Aggregate for Concrete*.

<sup>(7)</sup> Test method ASTM C231.

<sup>(8)</sup> Test method ASTM C1218 at age between 28 and 42 days.

<sup>(9)</sup> The total cementitious material also includes ASTM C150, C595, C845, and C1157 cement. The maximum percentages shall include:

- (a) Fly ash or other pozzolans in type IP, blended cement, ASTM C595, or ASTM C1157.
- (b) Slag used in the manufacture of an IS blended cement, ASTM C595, or ASTM C1157.
- (c) Silica fume, ASTM C1240, present in a blended cement.

<sup>(10)</sup> Fly ash or other pozzolans and silica fume shall constitute no more than 25 and 10 percent, respectively, of the total weight of the cementitious materials.





# CSI SPECIFICATIONS



---

# Precast Modular Block Retaining Wall Specification

## CSI Format

02/11/15

The following specification addresses PMB walls designed as unreinforced gravity structures or reinforced with geosynthetic reinforcement. This document is a guide specification and should be modified as necessary for your particular project. An editable version of this document is available for download at [redi-rock.com](http://redi-rock.com).

## **SECTION 32 32 16**

### **PRECAST MODULAR BLOCK RETAINING WALL**

#### **PART 1 – GENERAL**

##### **1.01 SUMMARY**

- A. This Section includes furnishing all materials and labor required for the design and construction of a precast concrete modular block (PMB) retaining wall with or without geosynthetic reinforcement. Precast modular block retaining wall blocks under this section shall be cast utilizing a wet-cast concrete mix and exhibit a final handling weight in excess of 1,000 pounds (450 kilograms) per unit.
- B. Scope of Work: The work shall consist of furnishing materials, labor, equipment, and supervision for the construction of a precast modular block (PMB) retaining wall structure in accordance with the requirements of this section and in acceptable conformity with the lines, grades, design, and dimensions shown in the project site plans.
- C. Drawings and General Provisions of the Contract, including General and Supplementary Conditions and Division 31, Division 32, and Division 33 also apply to this Section.

##### **1.02 PRICE AND PAYMENT PROCEDURES**

- A. Allowances. No allowance shall be made in the price of the retaining wall for excavation beyond the limits required for retaining wall construction as shown on the project plans. The cost of excavation for the purposes of site access shall be the responsibility of the General Contractor. Removal of unsuitable soils and replacement with select fill shall be as directed and approved in writing by the Owner or Owner's representative and shall be paid under separate pay items.
- B. Unit Prices. In addition to a lump-sum price pursuant to completion of the scope of work described in Part 1.01 of this Section, the General Contractor shall provide a unit price per square foot of vertical wall face that shall be the basis of compensation for up to a ten percent (10%) increase or reduction in the overall scope of the retaining wall work.
- C. Measurement and Payment.
1. The unit of measurement for furnishing the precast modular block retaining wall system shall be the vertical area of the wall face surface as measured from the top of the leveling pad to the top of the wall including coping. The final measured quantity shall include supply of all material components and the installation of the precast modular block system.
  2. The final accepted quantities of the precast modular block retaining wall system will be compensated per the vertical face area as described above. The quantities of the precast modular block retaining wall as shown on the plans and as approved by the Owner shall be the basis for determination of the final payment quantity. Payment shall be made per square foot of vertical wall face.

### 1.03 REFERENCES

A. Where the specification and reference documents conflict, the Owner's designated representative will make the final determination of the applicable document.

#### B. Definitions:

1. Precast Modular Block (PMB) Unit – machine-placed, wet-cast concrete modular block retaining wall facing unit.
2. Geotextile – a geosynthetic fabric manufactured for use as a separation and filtration medium between dissimilar soil materials.
3. Geogrid – a geosynthetic material comprised of a regular network of tensile elements manufactured in a mesh-like configuration of consistent aperture openings. When connected to the PMB facing units and placed in horizontal layers in compacted fill, the geogrid prevents lateral deformation of the retaining wall face and provides effective tensile reinforcement to the contiguous reinforced fill material.
4. Drainage Aggregate – clean, crushed stone placed within and immediately behind the precast modular block units to facilitate drainage and reduce compaction requirements immediately adjacent to and behind the precast modular block units.
5. Unit Core Fill – clean, crushed stone placed within the hollow vertical core of a precast modular block unit. Typically, the same material used for drainage aggregate as defined above.
6. Foundation Zone – soil zone immediately beneath the leveling pad and the reinforced zone.
7. Retained Zone – soil zone immediately behind the drainage aggregate and wall infill for wall sections designed as modular gravity structures. Alternatively, in the case of wall sections designed with geosynthetic soil reinforcement, the retained zone is the soil zone immediately behind the reinforced zone.
8. Reinforced Zone – structural fill zone within which successive horizontal layers of geogrid soil reinforcement have been placed to provide stability for the retaining wall face. The reinforced zone exists only for retaining wall sections that utilize geosynthetic soil reinforcement for stability.
9. Reinforced Fill – structural fill placed within the reinforced zone.
10. Leveling Pad – hard, flat surface upon which the bottom course of precast modular blocks are placed. The leveling pad may be constructed with crushed stone or cast-in-place concrete. A leveling pad is not a structural footing.
11. Wall Infill – the fill material placed and compacted between the drainage aggregate and the excavated soil face in retaining wall sections designed as modular gravity structures.

## C. Reference Standards

### 1. Design

- a. AASHTO LRFD Bridge Design Specifications, 7th Edition, 2014.
- b. Minimum Design Loads for Buildings and Other Structures – ASCE/SEI 7-10.
- c. International Building Code, 2012 Edition.
- d. FHWA-NHI-10-024 Volume I and GEC 11 Design of Mechanically Stabilized Earth Walls and Reinforced Soil Slopes.
- e. FHWA-NHI-10-025 Volume II and GEC 11 Design of Mechanically Stabilized Earth Walls and Reinforced Soil Slopes.

### 2. Precast Modular Block Units

- a. ASTM C94 – Standard Specification for Ready-Mixed Concrete.
- b. ASTM C136 – Standard Test Method for Sieve Analysis of Fine and Coarse Aggregates.
- c. ASTM C143 – Standard Test Method for Slump of Hydraulic-Cement Concrete.
- d. ASTM C260 – Standard Specification for Air-Entraining Admixtures for Concrete.
- e. ASTM C494 – Standard Specification for Chemical Admixtures for Concrete.
- f. ASTM C666 – Standard Test Method for Concrete Resistance to Rapid Freezing and Thawing.
- g. ASTM C920 – Standard Specification for Elastomeric Joint Sealants.
- h. ASTM C1116 – Standard Specification for Fiber-Reinforced Concrete.
- i. ASTM C1611 – Standard Test Method for Slump Flow of Self-Consolidating Concrete.
- j. ASTM D6638 – Standard Test Method for Determining Connection Strength Between Geosynthetic Reinforcement and Segmental Concrete Units (Modular Concrete Blocks).
- k. ASTM D6916 – Standard Test Method for Determining Shear Strength Between Segmental Concrete Units (Modular Concrete Blocks).

### 3. Geosynthetics

- a. AASHTO M 288 – Geotextile Specification for Highway Applications.
- b. ASTM D3786 – Standard Test Method for Bursting Strength of Textile Fabrics Diaphragm Bursting Strength Tester Method.
- c. ASTM D4354 – Standard Practice for Sampling of Geosynthetics for Testing.
- d. ASTM D4355 – Standard Test Method for Deterioration of Geotextiles
- e. ASTM D4491 – Standard Test Methods for Water Permeability of Geotextiles by Permittivity.
- f. ASTM D4533 – Standard Test Method for Trapezoid Tearing Strength of Geotextiles.
- g. ASTM D4595 – Standard Test Method for Tensile Properties of Geotextiles by the Wide-Width Strip Method.
- h. ASTM D4632 – Standard Test Method for Grab Breaking Load and Elongation of Geotextiles.

- i. ASTM D4751 – Standard Test Method for Determining Apparent Opening Size of a Geotextile.
- j. ASTM D4759 – Standard Practice for Determining Specification Conformance of Geosynthetics.
- k. ASTM D4833 – Standard Test Method for Index Puncture Resistance of Geomembranes and Related Products.
- l. ASTM D4873 – Standard Guide for Identification, Storage, and Handling of Geosynthetic Rolls and Samples.
- m. ASTM D5262 – Standard Test Method for Evaluating the Unconfined Tension Creep and Creep Rupture Behavior of Geosynthetics.
- n. ASTM D5321 – Standard Test Method for Determining the Coefficient of Soil and Geosynthetic or Geosynthetic and Geosynthetic Friction by the Direct Shear Method.
- o. ASTM D5818 – Standard Practice for Exposure and Retrieval of Samples to Evaluate Installation Damage of Geosynthetics.
- p. ASTM D6241 – Standard Test Method for the Static Puncture Strength of Geotextiles and Geotextile-Related Products Using a 50-mm Probe.
- q. ASTM D6637 – Standard Test Method for Determining Tensile Properties of Geogrids by the Single or Multi-Rib Tensile Method.
- r. ASTM D6706 – Standard Test Method for Measuring Geosynthetic Pullout Resistance in Soil.
- s. ASTM D6992 – Standard Test Method for Accelerated Tensile Creep and Creep-Rupture of Geosynthetic Materials Based on Time-Temperature Superposition Using the Stepped Isothermal Method.

#### 4. Soils

- a. AASHTO M 145 – AASHTO Soil Classification System.
- b. AASHTO T 104 – Standard Method of Test for Soundness of Aggregate by Use of Sodium Sulfate or Magnesium Sulfate.
- c. AASHTO T 267 – Standard Method of Test for Determination of Organic Content in Soils by Loss of Ignition.
- d. ASTM C33 – Standard Specification for Concrete Aggregates.
- e. ASTM D422 – Standard Test Method for Particle-Size Analysis of Soils.
- f. ASTM D448 – Standard Classification for Sizes of Aggregates for Road and Bridge Construction.
- g. ASTM D698 – Standard Test Method for Laboratory Compaction Characteristics of Soil Using Standard Effort. (12,400 ft-lb/ft (2,700 kN-m/m)).
- h. ASTM D1241 – Standard Specification for Materials for Soil-Aggregate Subbase, Base and Surface Courses.
- i. ASTM D1556 – Standard Test Method for Density and Unit Weight of Soil in Place by Sand-Cone Method.

- j. ASTM D1557 – Standard Test Method for Laboratory Compaction Characteristics of Soil Using Modified Effort. (56,000 ft-lb./ft (2,700 kN-m/m)).
- k. ASTM D2487 – Standard Practice for Classification of Soils for Engineering Purposes (Unified Soil Classification System).
- l. ASTM D2488 – Standard Practice for Description and Identification of Soils (Visual-Manual Procedure).
- m. ASTM D3080 – Standard Test Method for Direct Shear Test of Soils Under Consolidated Drained Conditions.
- n. ASTM D4254 – Standard Test Method for Minimum Index Density and Unit Weight of Soils and Calculation of Relative Density.
- o. ASTM D4318 – Standard Test Method for Liquid Limit, Plastic Limit, and Plasticity Index of Soils.
- p. ASTM D4767- Test Method for Consolidated-Undrained Triaxial Compression Test for Cohesive Soils.
- q. ASTM D4972 – Standard Test Method for pH of Soils.
- r. ASTM D6938 – Standard Test Method for In-Place Density and Water Content of Soil and Aggregate by Nuclear Methods (Shallow Depth).
- s. ASTM G51 – Standard Test Method for Measuring pH of Soil for Use in Corrosion Testing.
- t. ASTM G57 – Standard Test Method for Field Measurement of Soil Resistivity Using the Wenner Four-Electrode Method.

#### 5. Drainage Pipe

- a. ASTM D3034 – Standard Specification for Type PSM Poly (Vinyl Chloride) (PVC) Sewer Pipe and Fittings.
- b. ASTM F2648 – Standard Specification for 2 to 60 inch [50 to 1500 mm] Annular Corrugated Profile Wall Polyethylene (PE) Pipe and Fittings for Land Drainage Applications.

### 1.04 ADMINISTRATIVE REQUIREMENTS

A. Preconstruction Meeting. As directed by the Owner, the General Contractor shall schedule a preconstruction meeting at the project site prior to commencement of retaining wall construction. Participation in the preconstruction meeting shall be required of the General Contractor, Retaining Wall Design Engineer, Retaining Wall Installation Contractor, Grading Contractor, and Inspection Engineer. The General Contractor shall provide notification to all parties at least 10 calendar days prior to the meeting.

#### 1. Preconstruction Meeting Agenda:

- a. The Retaining Wall Design Engineer shall explain all aspects of the retaining wall construction drawings.
- b. The Retaining Wall Design Engineer shall explain the required bearing capacity of soil below

the retaining wall structure and the shear strength of in-situ soils assumed in the retaining wall design to the Inspection Engineer.

- c. The Retaining Wall Design Engineer shall explain the required shear strength of fill soil in the reinforced, retained, and foundation zones of the retaining wall to the Inspection Engineer.
- d. The Retaining Wall Design Engineer shall explain any measures required for coordination of the installation of utilities or other obstructions in the reinforced or retained fill zones of the retaining wall.
- e. The Retaining Wall Installation Contractor shall explain all excavation needs, site access, and material staging area requirements to the General Contractor and Grading Contractor.

### 1.05 SUBMITTALS

A. Product Data. At least 14 days prior to construction, the General Contractor shall submit a minimum of six (6) copies of the retaining wall product submittal package to the Owner's Representative for review and approval. The submittal package shall include technical specifications and product data from the manufacturer for the following:

1. Precast Modular Block System brochure
2. Precast Modular Block concrete test results specified in paragraph 2.01, subparagraph B of this section as follows:
  - a. 28-day compressive strength
  - b. Air content
  - c. Slump or Slump Flow (as applicable)
3. Drainage Pipe
4. Geotextile
5. Geosynthetic Soil Reinforcement (if required by the retaining wall design). The contractor shall provide certified manufacturer test reports for the geosynthetic soil reinforcement material in the manufactured roll width specified. The test report shall list the individual roll numbers for which the certified material properties are valid.

B. Installer Qualification Data. At least 14 days prior to construction, the General Contractor shall submit the qualifications of the business entity responsible for installation of the retaining wall, the Retaining Wall Installation Contractor, per paragraph 1.07, subparagraph A of this section.

C. Retaining Wall Design Calculations and Construction Shop Drawings. At least 14 days prior to construction, the General Contractor shall furnish six (6) sets of construction shop drawings and six (6) copies of the supporting structural calculations report to the Owner for review and approval. This submittal shall include the following:

1. Signed, sealed, and dated drawings and engineering calculations prepared in accordance with these specifications.
2. Qualifications Statement of Experience of the Retaining Wall Design Engineer as specified in paragraph 1.07, subparagraph B of this section.
3. Certificate of Insurance of the Retaining Wall Design Engineer as specified in paragraph 1.06, subparagraph B of this section.

#### 1.06 CONSTRUCTION SHOP DRAWING PREPARATION

- A. The Retaining Wall Design Engineer shall coordinate the retaining wall construction shop drawing preparation with the project Civil Engineer, project Geotechnical Engineer and Owner's Representatives. The General Contractor shall furnish the Retaining Wall Design Engineer the following project information required to prepare the construction shop drawings. This information shall include, but is not limited to, the following:
1. Current versions of the site, grading, drainage, utility, erosion control, landscape, and irrigation plans;
  2. electronic CAD file of the civil site plans listed in (1);
  3. report of geotechnical investigation and all addenda and supplemental reports;
  4. recommendations of the project Geotechnical Engineer regarding effective stress shear strength and total stress shear strength (when applicable) parameters for in-situ soils in the vicinity of the proposed retaining wall(s) and for any fill soil that may potentially be used as backfill in retained and/or foundation zones of the retaining wall.
- B. The Retaining Wall Design Engineer shall provide the Owner with a certificate of professional liability insurance verifying the minimum coverage limits of \$1 million per claim and \$1 million aggregate.
- C. Design of the precast modular block retaining wall shall satisfy the requirements of this section. Where local design or building code requirements exceed these specifications, the local requirements shall also be satisfied.
- D. The Retaining Wall Design Engineer shall note any exceptions to the requirements of this section by listing them at the bottom right corner of the first page of the construction shop drawings.
- E. Approval or rejection of the exceptions taken by the Retaining Wall Engineer will be made in writing as directed by the Owner.
- F. The precast modular block design, except as noted herein, shall be based upon AASHTO Load and Resistance Factor Design (LRFD) methodology as referenced in paragraph 1.03, subparagraph C.1.

- G. In the event that a conflict is discovered between these specifications and a reasonable interpretation of the design specifications and methods referenced in paragraph F above, these specifications shall prevail. If a reasonable interpretation is not possible, the conflict shall be resolved per the requirements in paragraph 1.03, subparagraph A of this section.
- H. Soil Shear Parameters. The Retaining Wall Design Engineer shall prepare the construction shop drawings based upon soil shear strength parameters from the available project data and the recommendations of the project Geotechnical Engineer. If insufficient data exists to develop the retaining wall design, the Retaining Wall Design Engineer shall communicate the specific deficiency of the project information or data to the Owner in writing.
- I. Allowable bearing pressure requirements for each retaining wall shall be clearly shown on the construction drawings.
- J. Global Stability. Overall (global) stability shall be evaluated in accordance with the principals of limit equilibrium analysis as set forth in FHWA-NHI-10-024 Volume I and FHWA-NHI-10-025 Volume II GEC 11 Design of Mechanically Stabilized Earth Walls and Reinforced Soil Slopes as referenced in paragraph 1.03, subparagraph C.1. The minimum factors of safety shall be as follows:

Normal Service (Static)	1.4
Seismic	1.1
<u>Rapid Drawdown (if applicable)</u>	1.2

- K. Seismic Stability. Seismic loading shall be evaluated in accordance with AASHTO Load and Resistance Factor Design (LRFD) methodology as referenced in paragraph 1.03, subparagraph C.1.

## 1.07 QUALITY ASSURANCE

- A. Retaining Wall Installation Contractor Qualifications. In order to demonstrate basic competence in the construction of precast modular block walls, the Retaining Wall Installation Contractor shall document compliance with the following:

### 1. Experience.

- a. Construction experience with a minimum of 30,000 square feet (2,787 square meters) of the proposed precast modular block retaining wall system.
- b. Construction of at least ten (10) precast modular block (large block) retaining wall structures within the past three (3) years.
- c. Construction of at least 50,000 square feet (4,645 square meters) of precast modular block (large block) retaining walls within the past three (3) years.

2. Retaining Wall Installation Contractor experience documentation for each qualifying project shall include:
  - a. Project name and location
  - b. Date (month and year) of construction completion
  - c. Contact information of Owner or General Contractor
  - d. Type (trade name) of precast modular block system built
  - e. Maximum height of the wall constructed
  - f. Face area of the wall constructed
3. In lieu of the requirements set forth in items 1 and 2 above, the Retaining Wall Installation Contractor must be a certified Precast Modular Block Retaining Wall Installation Contractor as demonstrated by satisfactory completion of a certified precast modular block retaining wall installation training program administered by the precast modular block manufacturer.

B. Retaining Wall Design Engineer Qualifications and Statement of Experience. The Retaining Wall Design Engineer shall submit a written statement affirming that he or she has the following minimum qualifications and experience.

1. The Retaining Wall Design Engineer shall be licensed to practice in the jurisdiction of the project location.
2. The Retaining Wall Design Engineer shall be independently capable of performing all internal and external stability analyses, including those for seismic loading, compound stability, rapid draw-down, and deep-seated, global modes of failure.
3. The Retaining Wall Design Engineer shall affirm in writing that he or she has personally supervised the design of the retaining walls for the project, that the design considers all the requirements listed in paragraph 1.06, and that he or she accepts responsibility as the design engineer of record for the retaining walls constructed on the project.
4. The Retaining Wall Design Engineer shall affirm in writing that he or she has personally designed in excess of 100,000 face square feet (9,290 face square meters) of modular block earth retaining walls within the previous three (3) years.

C. The Owner reserves the right to reject the design services of any engineer or engineering firm who, in the sole opinion of the Owner, does not possess the requisite experience or qualifications.

## 1.08 QUALITY CONTROL

A. The Owner's Representative shall review all submittals for materials, design, Retaining Wall Design Engineer qualifications, and the Retaining Wall Installation Contractor qualifications.

B. The General Contractor shall retain the services of an Inspection Engineer who is experienced with the construction of precast modular block retaining wall structures to perform inspection and testing. The cost of inspection shall be the responsibility of the General Contractor. Inspection shall be continuous throughout the construction of the retaining walls.

C. The Inspection Engineer shall perform the following duties:

1. Inspect the construction of the precast modular block structure for conformance with construction shop drawings and the requirements of this specification.
2. Verify that soil or aggregate fill placed and compacted in the reinforced, retained, and foundation zones of the retaining wall conforms with paragraphs 2.04 and 2.05 of this section and exhibits the shear strength parameters specified by the Retaining Wall Design Engineer.
3. Verify that the shear strength of the in-situ soil assumed by the Retaining Wall Design Engineer is appropriate.
4. Inspect and document soil compaction in accordance with these specifications:
  - a. Required dry unit weight
  - b. Actual dry unit weight
  - c. Allowable moisture content
  - d. Actual moisture content
  - e. Pass/fail assessment
  - f. Test location – wall station number
  - g. Test elevation
  - h. Distance of test location behind the wall face
5. Verify that all excavated slopes in the vicinity of the retaining wall are bench-cut as directed by the project Geotechnical Engineer.
6. Notify the Retaining Wall Installation Contractor of any deficiencies in the retaining wall construction and provide the Retaining Wall Installation Contractor a reasonable opportunity to correct the deficiency.
7. Notify the General Contractor, Owner, and Retaining Wall Design Engineer of any construction deficiencies that have not been corrected in a timely fashion.
8. Document all inspection results.
9. Test compacted density and moisture content of the retained backfill with the following frequency:
  - a. At least once every 1,000 square feet (93 square meters) (in plan) per 9-inch (229 millimeter) vertical lift, and
  - b. At least once per every 18 inches (457 millimeter) of vertical wall construction.

- D. The General Contractor's engagement of the Inspection Engineer does not relieve the Retaining Wall Installation Contractor of responsibility to construct the proposed retaining wall in accordance with the approved construction shop drawings and these specifications.
- E. The Retaining Wall Installation Contractor shall inspect the on-site grades and excavations prior to construction and notify the Retaining Wall Design Engineer and General Contractor if on-site conditions differ from the elevations and grading conditions depicted in the retaining wall construction shop drawings.

#### 1.09 DELIVERY, STORAGE AND HANDLING

- A. The Retaining Wall Installation Contractor shall inspect the materials upon delivery to ensure that the proper type, grade, and color of materials have been delivered.
- B. The Retaining Wall Installation Contractor shall store and handle all materials in accordance with the manufacturer's recommendations as specified herein and in a manner that prevents deterioration or damage due to moisture, temperature changes, contaminants, corrosion, breaking, chipping, UV exposure, or other causes. Damaged materials shall not be incorporated into the work.

#### C. Geosynthetics

1. All geosynthetic materials shall be handled in accordance with ASTM D4873. The materials should be stored off the ground and protected from precipitation, sunlight, dirt, and physical damage.

#### D. Precast Modular Blocks

1. Precast modular blocks shall be stored in an area with positive drainage away from the blocks. Be careful to protect the block from mud and excessive chipping and breakage. Precast modular blocks shall not be stacked more than three (3) units high in the storage area.

#### E. Drainage Aggregate and Backfill Stockpiles

1. Drainage aggregate or backfill material shall not be piled over unstable slopes or areas of the project site with buried utilities.
2. Drainage aggregate and/or reinforced fill material shall not be staged where it may become mixed with or contaminated by poor draining fine-grained soils such as clay or silt.

**PART 2 – MATERIALS****2.01 PRECAST MODULAR BLOCK RETAINING WALL UNITS**

- A. All units for the project shall be obtained from the same manufacturer. The manufacturer shall be licensed and authorized to produce the retaining wall units by the precast modular block system patent holder/licensor and shall document compliance with the published quality control standards of the proprietary precast modular block system licensor for the previous three (3) years.
- B. Concrete used in the production of the precast modular block units shall be first-purpose, fresh concrete. It shall not consist of returned, reconstituted, surplus, or waste concrete. It shall be an original production mix meeting the requirements of ASTM C94 and exhibit the following:
1. Minimum 28-day compressive strength of 4,000 psi (27.6 MPa).
  2. Shall be free of water soluble chlorides and chloride based accelerator admixtures.
  3.  $6\% \pm 1\frac{1}{2}\%$  air-entrainment in conformance ASTM C94.
  4. Maximum slump of 5 inches  $\pm 1\frac{1}{2}$  inches (127 millimeter  $\pm 38$  millimeter) per ASTM C143 for conventional concrete mix designs.
  5. Slump Flow for Self-Consolidating Concrete (SCC) mix designs shall be between 18 inches and 32 inches (457 millimeter and 813 millimeter) as tested in accordance with ASTM C1611.
- C. Each concrete block shall be cast in a single continuous pour without cold joints. With the exception of half-block units, corner units, and other special application units, the precast modular block units shall conform to the nominal dimensions listed in the table below and be produced to the dimensional tolerances shown.

Block Type	Dimension	Nominal Value	Tolerance
28" (710 mm) Block	Height	18" (457 mm)	$\pm 3/16"$ (5 mm)
	Length	46-1/8" (1172 mm)	$\pm 1/2"$ (13 mm)
	Width*	28" (710 mm)	$\pm 1/2"$ (13 mm)
41" (1030 mm) Block	Height	18" (457 mm)	$\pm 3/16"$ (5 mm)
	Length	46-1/8" (1172 mm)	$\pm 1/2"$ (13 mm)
	Width*	40-1/2" (1030 mm)	$\pm 1/2"$ (13 mm)
60" (1520 mm) Block	Height	18" (457 mm)	$\pm 3/16"$ (5 mm)
	Length	46-1/8" (1172 mm)	$\pm 1/2"$ (13 mm)
	Width*	60" (1520 mm)	$\pm 1/2"$ (13 mm)

\* Excluding Variable Face Texture

- D. Individual block units shall have a nominal height of 18 inches (457 millimeters).

- E. With the exception of half-block units, corner units, and other special application units, the precast modular block units shall have two (2) circular dome shear knobs that are 10 inches (254 millimeters) maximum in diameter and 4 inches (102 millimeters) maximum in height. The shear knobs shall fully index into a continuous semi-cylindrical shear channel in the bottom of the block course above. Peak interlock shear between any two (2) vertically stacked precast modular block units measured in accordance with ASTM D6916 shall exceed 6,500 lb/ft (95 kN/m) at a minimum normal load of 500 lb/ft (7kN/m), as well as an ultimate peak interface shear capacity in excess of 11,000 lb/ft (160 kN/m). Test specimen blocks tested under ASTM D6916 shall be actual, full-scale production blocks of known compressive strength. The interface shear capacity reported shall be corrected for a 4,000 psi (27.6 MPa) concrete compressive strength. Regardless of precast modular block configuration, interface shear testing shall be completed without the inclusion of unit core infill aggregate.
- F. The 28 inch (710 millimeters) and 41 inch (1030 millimeters) precast modular block units shall be cast with a 13 inch (330 millimeters) wide continuous vertical core slot that will permit the insertion of a 12 inch (305 millimeters) wide strip of geogrid reinforcement to pass completely through the block. When installed in this manner, the geogrid reinforcement shall form a non-normal load dependent, positive connection between the block unit and the reinforcement strip. The use of steel for the purposes of creating the geogrid-to-block connection is not acceptable.
- G. Without field cutting or special modification, the precast modular block units shall be capable of achieving a minimum radius of 14 foot 6 inch (4.42 meters).
- H. The precast modular block units shall be manufactured with integrally cast shear knobs that establish a standard horizontal set-back for subsequent block courses. The precast modular block system shall be available in the four (4) standard horizontal setback facing batter options listed below:

<u>Horizontal Setback/Block Course</u>	<u>Max. Facing Batter</u>
3/8" (10 mm)	1.2°
1-5/8" (41 mm)	5.2°
9-3/8" (238 mm)	27.5°
16-5/8" (422 mm)	42.7°

The precast modular block units shall be furnished with the required shear knobs that provide the facing batter required in the construction shop drawings.

- I. The precast modular block unit face texture shall be selected by the owner from the available range of textures available from the precast modular block manufacturer. Each textured block facing unit shall be a minimum of 5.75 square feet (0.54 square meters) with a unique texture pattern that repeats with a maximum frequency of once in any 20 square feet (1.87 square meters) of wall face.

J. The block color shall be selected by the owner from the available range of colors available from the precast modular block manufacturer.

K. All precast modular block units shall be sound and free of cracks or other defects that would interfere with the proper installation of the unit, impair the strength or performance of the constructed wall. PMB units to be used in exposed wall construction shall not exhibit chips or cracks in the exposed face or faces of the unit that are not otherwise permitted. Chips smaller than 1.5 inches (38 millimeters) in its largest dimension and cracks not wider than 0.012 inch (0.3 millimeter) and not longer than 25% of the nominal height of the PMB unit shall be permitted. PMB units with bug holes in the exposed architectural face smaller than 0.75 inch (19 millimeter) in its largest dimension shall be permitted. Bug holes, water marks, and color variation on non-architectural faces are acceptable. PMB units that exhibit cracks that are continuous through any solid element of the PMB unit shall not be incorporated in the work regardless of the width or length of the crack.

L. Preapproved Manufacturers.

1. Manufacturers of Redi-Rock Retaining Wall Systems as licensed by Redi-Rock International, LLC, 05481 US 31 South, Charlevoix, MI 49720 USA; telephone (866) 222-8400; website [redi-rock.com](http://redi-rock.com).

M. Substitutions. Technical information demonstrating conformance with the requirements of this specification for an alternative precast modular block retaining wall system must be submitted for preapproval at least 14 calendar days prior to the bid date. Acceptable alternative PMB retaining wall systems, otherwise found to be in conformance with this specification, shall be approved in writing by the owner seven (7) days prior to the bid date. The Owner's Representative reserves the right to provide no response to submissions made out of the time requirements of this section or to submissions of block retaining wall systems that are determined to be unacceptable to the owner.

N. Value Engineering Alternatives. The owner may evaluate and accept systems that meet the requirements of this specification after the bid date that provide a minimum cost savings of 20% to the Owner. Construction expediency will not be considered as a contributing portion of the cost savings total.

## 2.02 GEOGRID REINFORCEMENT

A. Geogrid reinforcement shall be a woven or knitted PVC coated geogrid manufactured from high-tenacity PET polyester fiber with an average molecular weight greater than 25,000 ( $M_n > 25,000$ ) and a carboxyl end group less than 30 ( $CEG < 30$ ). The geogrid shall be furnished in prefabricated roll widths of certified tensile strength by the manufacturer. The prefabricated roll width of the geogrid shall be 12 inches (305 millimeters)  $\pm 1/2$  inch (13 millimeters). No cutting of geogrid reinforcement down to the 12 inches (305 millimeters) roll width from a larger commercial roll width will be allowed under any circumstances.

- B. The ultimate tensile strength ( $T_{ult}$ ) of the geogrid reinforcement shall be measured in accordance with ASTM D6637.
- C. Geogrid – Soil Friction Properties.
1. Friction factor,  $F^*$ , shall be equal to  $2/3 \tan \phi$ , where  $\phi$  is the effective angle of internal friction of the reinforced fill soil.
  2. Linear Scale Correction Factor,  $\alpha$ , shall equal 0.8.
- D. Long-Term Tensile Strength ( $T_{al}$ ) of the geogrid reinforcement shall be calculated in accordance with Section 3.5.2 of FHWA-NHI-10-024 and as provided in this specification.
1. The creep reduction factor ( $RF_{cr}$ ) shall be determined in accordance with Appendix D of FHWA-NHI-10-025 for a minimum 75 year design life.
  2. Minimum installation damage reduction factor ( $RF_{ID}$ ) shall be 1.25. The value of  $RF_{ID}$  shall be based upon documented full-scale tests in a soil that is comparable to the material proposed for use as reinforced backfill in accordance with ASTM D5818.
  3. Minimum durability reduction factor ( $RF_D$ ) shall be 1.3 for a soil pH range of 3 to 9.
- E. Connection between the PMB retaining wall unit and the geogrid reinforcement shall be determined from short-term testing per the requirements of FHWA NHI-10-025, Appendix B.4 for a minimum 75-year design life.
- F. The minimum value of  $T_{al}$  for geogrid used in design of a reinforced precast modular block retaining wall shall be 2,000 lb/ft (29 kN/m) or greater.
- G. The minimum length of geogrid reinforcement shall be the greater of the following:
1. 0.7 times the wall design height, H.
  2. 5 feet (1.5 meters).
  3. The length required by design to meet internal stability requirements, soil bearing pressure requirements and constructibility requirements.
- H. Constructibility Requirements. Geogrid design embedment length shall be measured from the back of the precast modular block facing unit and shall be consistent for the entire height of a given retaining wall section.

I. Geogrid shall be positively connected to every precast modular block unit. Design coverage ratio,  $R_c$ , as calculated in accordance with AASHTO LRFD Bridge Design Specifications Figure 11.10.6.4.1-2 shall not exceed 0.50.

J. Preapproved Geogrid Reinforcement Products.

1. Miragrid XT Geogrids as manufactured by TenCate Geosynthetics of Pendergrass, Georgia USA and distributed by Manufacturers of the Redi-Rock Retaining Wall System.

K. Substitutions. No substitutions of geogrid reinforcement products shall be allowed.

## 2.03 GEOTEXTILE

A. Nonwoven geotextile fabric shall be placed as indicated on the retaining wall construction shop drawings. Additionally, the nonwoven geotextile fabric shall be placed in the v-shaped joint between adjacent block units on the same course. The nonwoven geotextile fabric shall meet the requirements Class 3 construction survivability in accordance with AASHTO M 288.

B. Preapproved Nonwoven Geotextile Products

1. Mirafi 140N
2. Propex Geotex 451
3. Skaps GT-142
4. Thrace-Linq 140EX
5. Carthage Mills FX-40HS
6. Stratatex ST 142

## 2.04 DRAINAGE AGGREGATE AND WALL INFILL

A. Drainage aggregate (and wall infill for retaining walls designed as modular gravity structures) shall be a durable crushed stone conforming to No. 57 size per ASTM C33 with the following particle-size distribution requirements per ASTM D422:

U.S. Standard Sieve Size	% Passing
1-½" (38 mm)	100
1" (25 mm)	95-100
½" (13 mm)	25-60
No. 4 (4.76 mm)	0-10
No. 8 (2.38 mm)	0-5

## 2.05 REINFORCED FILL

A. Material used as reinforced backfill material in the reinforced zone (if applicable) shall be a granular fill material meeting the requirements of USCS soil type GW, GP, SW or SP per ASTM D2487 or alternatively by AASHTO Group Classification A-1-a or A-3 per AASHTO M 145. The backfill shall exhibit a minimum effective internal angle of friction,  $\phi = 34$  degrees at a maximum 2% shear strain and meet the following particle-size distribution requirements per ASTM D422.

U.S. Standard Sieve Size	% Passing
1-1/2" (38 mm)	100
No. 4 (4.76 mm)	0-100
No. 40 (0.42 mm)	0-60
No. 100 (0.15 mm)	0-10
No. 200 (0.07 mm)	0-5

B. The reinforced backfill material shall be free of sod, peat, roots, or other organic or deleterious matter including, but not limited to, ice, snow, or frozen soils. Materials passing the No. 40 (0.42 millimeter) sieve shall have a liquid limit less than 25 and plasticity index less than 6 per ASTM D4318. Organic content in the backfill material shall be less than 1% per AASHTO T-267 and the pH of the backfill material shall be between 5 and 8.

C. Soundness. The reinforced backfill material shall exhibit a magnesium sulfate soundness loss of less than 30% after four (4) cycles, or sodium sulfate soundness loss of less than 15% after five (5) cycles as measured in accordance with AASHTO T-104.

D. Reinforced backfill shall not be comprised of crushed or recycled concrete, recycled asphalt, bottom ash, shale, or any other material that may degrade, creep, or experience a loss in shear strength or a change in pH over time.

## 2.06 LEVELING PAD

A. The precast modular block units shall be placed on a leveling pad constructed from crushed stone or unreinforced concrete. The leveling pad shall be constructed to the dimensions and limits shown on the retaining wall design drawings prepared by the Retaining Wall Design Engineer.

B. Crushed stone used for construction of a granular leveling pad shall meet the requirements of the drainage aggregate and wall infill in section 2.05 or a preapproved alternate material.

C. Concrete used for construction of an unreinforced concrete leveling pad shall satisfy the criteria for

AASHTO Class B. The concrete should be cured a minimum of 12 hours prior to placement of the precast modular block wall retaining units and exhibit a minimum 28-day compressive strength of 2,500 psi (17.2 MPa).

## 2.07 DRAINAGE

### A. Drainage Pipe

1. Drainage collection pipe shall be at least a 4-inch (102-millimeter) diameter, 3-hole perforated, HDPE pipe with a minimum pipe stiffness of 22 psi (152 kPa) per ASTM D2412.
2. The drainage pipe shall be manufactured in accordance with ASTM D1248 for HDPE pipe and fittings.

### B. Preapproved Drainage Pipe Products

1. ADS 3000 Triple Wall pipe as manufactured by Advanced Drainage Systems.

## PART 3 – EXECUTION

### 3.01 GENERAL

- A. All work shall be performed in accordance with OSHA safety standards, state and local building codes, and manufacturer's requirements.
- B. The General Contractor is responsible for the location and protection of all existing underground utilities. Any new utilities proposed for installation in the vicinity of the retaining wall shall be installed concurrent with retaining wall construction. The General Contractor shall coordinate the work of subcontractors affected by this requirement.
- C. New utilities installed below the retaining wall shall be backfilled and compacted to a minimum of 95% maximum dry density per ASTM D1557 modified proctor.
- D. The General Contractor is responsible to ensure that safe excavations and embankments are maintained throughout the course of the project.
- E. All work shall be inspected by the Inspection Engineer as directed by the Owner.

### 3.02 EXAMINATION

- A. Prior to construction, the General Contractor, Grading Contractor, Retaining Wall Installation Contractor, and Inspection Engineer shall examine the areas in which the retaining wall will be constructed to evaluate compliance with the requirements for installation tolerances, worker safety, and any site conditions

affecting performance of the completed structure. Installation shall proceed only after unsatisfactory conditions have been corrected.

### 3.03 PREPARATION

#### A. Fill Soil.

1. The Inspection Engineer shall verify that reinforced backfill placed in the reinforced soil zone satisfies the criteria of this section.
2. The Inspection Engineer shall verify that any fill soil installed in the foundation and retained soil zones of the retaining wall satisfies the specification of the Retaining Wall Design Engineer as shown on the construction drawings.

#### B. Excavation.

1. The Grading Contractor shall excavate to the lines and grades required for construction of the precast modular block retaining wall as shown on the construction drawings. The Grading Contractor shall minimize over-excavation. Excavation support, if required, shall be the responsibility of the Grading Contractor.
2. Over-excavated soil shall be replaced with compacted fill in conformance with the specifications of the Retaining Wall Design Engineer and "Division 31, Section 31 20 00 – Earthmoving" of these project specifications.
3. Embankment excavations shall be bench cut as directed by the project Geotechnical Engineer and inspected by the Inspection Engineer for compliance.

#### C. Foundation Preparation.

1. Prior to construction of the precast modular block retaining wall, the leveling pad area, and undercut zone (if applicable) shall be cleared and grubbed. All topsoil, brush, frozen soil, and organic material shall be removed. Additional foundation soils found to be unsatisfactory beyond the specified undercut limits shall be undercut and replaced with approved fill as directed by the project Geotechnical Engineer. The Inspection Engineer shall ensure that the undercut limits are consistent with the requirements of the project Geotechnical Engineer and that all soil fill material is properly compacted according project specifications. The Inspection Engineer shall document the volume of undercut and replacement.
2. Following excavation for the leveling pad and undercut zone (if applicable), the Inspection Engineer shall evaluate the in-situ soil in the foundation and retained soil zones.
  - a. The Inspection Engineer shall verify that the shear strength of the in-situ soil assumed by the Retaining Wall Design Engineer is appropriate. The Inspection Engineer shall immediately stop work and notify the Owner if the in-situ shear strength is found to be inconsistent with the retaining wall design assumptions.

- b. The Inspection Engineer shall verify that the foundation soil exhibits sufficient ultimate bearing capacity to satisfy the requirements indicated on the retaining wall construction shop drawings per paragraph 1.06 I of this section.

#### D. Leveling Pad.

1. The leveling pad shall be constructed to provide a level, hard surface on which to place the first course of precast modular block units. The leveling pad shall be placed in the dimensions shown on the retaining wall construction drawings and extend to the limits indicated.
2. Crushed Stone Leveling Pad. Crushed stone shall be placed in uniform maximum lifts of 6 inches (150 millimeter). The crushed stone shall be compacted by a minimum of three (3) passes of a vibratory compactor capable of exerting 2,000 lb (8.9 kN) of centrifugal force and to the satisfaction of the Inspection Engineer.
3. Unreinforced Concrete Leveling Pad. The concrete shall be placed in the same dimensions as those required for the crushed stone leveling pad. The Retaining Wall Installation Contractor shall erect proper forms as required to ensure the accurate placement of the concrete leveling pad according to the retaining wall construction drawings.

### 3.04 PRECAST MODULAR BLOCK WALL SYSTEM INSTALLATION

- A. The precast modular block structure shall be constructed in accordance with the construction drawings, these specifications, and the recommendations of the retaining wall system component manufacturers. Where conflicts exist between the manufacturer's recommendations and these specifications, these specifications shall prevail.
- B. Drainage components. Pipe, geotextile, and drainage aggregate shall be installed as shown on the construction shop drawings.
- C. Precast Modular Block Installation.
  1. The first course of block units shall be placed with the front face edges tightly abutted together on the prepared leveling pad at the locations and elevations shown on the construction drawings. The Retaining Wall Installation Contractor shall take special care to ensure that the bottom course of block units are in full contact with the leveling pad, are set level and true, and are properly aligned according to the locations shown on the construction drawings.
  2. Backfill shall be placed in front of the bottom course of blocks prior to placement of subsequent block courses. Nonwoven geotextile fabric shall be placed in the V-shaped joints between adjacent blocks. Drainage aggregate shall be placed in the V-shaped joints between adjacent blocks to a minimum distance of 12 inches (305 millimeters) behind the block unit.
  3. Drainage aggregate shall be placed in 9 inch (229 millimeter) maximum lifts and compacted by a

minimum of three (3) passes of a vibratory plate compactor capable exerting a minimum of 2,000 lb (8.9 kN) of centrifugal force.

4. Unit core fill shall be placed in the precast modular block unit vertical core slot. The core fill shall completely fill the slot to the level of the top of the block unit. The top of the block unit shall be broom-cleaned prior to placement of subsequent block courses. No additional courses of precast modular blocks may be stacked before the unit core fill is installed in the blocks on the course below. The core fill is required for blocks both with and without the geogrid reinforcement (install geogrid before core fill).
5. Base course blocks for gravity wall designs (without geosynthetic soil reinforcement) may be furnished without vertical core slots. If so, disregard item 4 above for the base course blocks in this application.
6. Nonwoven geotextile fabric shall be placed between the drainage aggregate and the retained soil (gravity wall design) or between the drainage aggregate and the reinforced fill (reinforced wall design) as required on the retaining wall construction drawings.
7. Subsequent courses of block units shall be installed with a running bond (half block horizontal course-to-course offset). With the exception of 90 degree corner units; the shear channel of the upper block shall be fully engaged with the shear knobs of the block course below. The upper block course shall be pushed forward to fully engage the interface shear key between the blocks and to ensure consistent face batter and wall alignment. Geogrid, drainage aggregate, unit core fill, geotextile, and properly compacted backfill shall be complete and in-place for each course of block units before the next course of blocks is stacked.
8. The elevation of retained soil fill shall not be less than 1 block course (18 inch (457 millimeters)) below the elevation of the reinforced backfill throughout the construction of the retaining wall.
9. If included as part of the precast modular block wall design, cap units shall be secured with an adhesive in accordance with the precast modular block manufacturer's recommendation.

#### D. Geogrid Reinforcement Installation (if required).

1. Geogrid reinforcement shall be installed at the locations and elevations shown on the construction drawings on level fill compacted to the requirements of this specification.
2. Continuous 12-inch (305-millimeter) wide strips of geogrid reinforcement shall be passed completely through the vertical core slot of the precast modular block unit and extended to the embedment length shown on the construction plans. The strips shall be staked or anchored as necessary to maintain a taut condition.
3. Reinforcement length (L) of the geogrid reinforcement is measured from the back of the precast modular block unit. The cut length ( $L_c$ ) is two times the reinforcement length plus additional length through the block facing unit. The cut length is calculated as follows:

$$L_c = 2*L + 3 \text{ ft } (2*L + 0.9 \text{ m}) \text{ (28-inch (710 millimeter) block unit)}$$

$$L_c = 2*L + 5 \text{ ft } (2*L + 1.5 \text{ m}) \text{ (41-inch (1030 millimeter) block unit)}$$

4. The geogrid strip shall be continuous throughout its entire length and may not be spliced. The geogrid shall be furnished in nominal, prefabricated roll widths of 12 inches (305 millimeters)  $\pm$  1/2 inch (13 millimeters). No field modification of the geogrid roll width shall be permitted.
5. Neither rubber tire nor track vehicles may operate directly on the geogrid. Construction vehicle traffic in the reinforced zone shall be limited to speeds of less than 5 mph (8 km/hr) once a minimum of 6 inches (152 millimeters) of compacted fill has been placed over the geogrid reinforcement. Sudden braking and turning of construction vehicles in the reinforced zone shall be avoided.

E. Construction Tolerance. Allowable construction tolerance of the retaining wall shall be as follows:

1. Deviation from the design batter and horizontal alignment, when measured along a 10 foot (3 meter) straight wall section, shall not exceed 3/4 inch (19 millimeter).
2. Deviation from the overall design batter shall not exceed 1/2 inch (13 millimeter) per 10 foot (3 meter) of wall height.
3. The maximum allowable offset (horizontal bulge) of the face in any precast modular block joint shall be 1/2 inch (13 millimeter).
4. The base of the precast modular block wall excavation shall be within 2 inches (51 millimeter) of the staked elevations, unless otherwise approved by the Inspection Engineer.
5. Differential vertical settlement of the face shall not exceed 1 foot (305 millimeter) along any 200 feet (61 meters) of wall length.
6. The maximum allowable vertical displacement of the face in any precast modular block joint shall be 1/2 inch (13 millimeter).
7. The wall face shall be placed within 2 inches (51 millimeters) of the horizontal location staked.

### 3.05 WALL INFILL AND REINFORCED BACKFILL PLACEMENT

A. Backfill material placed immediately behind the drainage aggregate shall be compacted as follows:

1. 90% of maximum dry density at  $\pm$  2% optimum moisture content per ASTM D1557 modified proctor or 85% relative density per ASTM D4254.

B. Compactive effort within 3 feet (0.9 meters) of the back of the precast modular blocks should be accomplished with walk-behind compactors. Compaction in this zone shall be within 90% of maximum dry density at  $\pm$  2% optimum moisture content as measured in accordance with ASTM D1557 modified proctor or 85% relative density per ASTM D4254. Heavy equipment should not be operated within 4 feet (1.2 meters) of the wall face.

C. Backfill material shall be installed in lifts that do not exceed a compacted thickness of 9 inches (229 millimeters).

- D. At the end of each work day, the Retaining Wall Installation Contractor shall grade the surface of the last lift of the granular wall infill to a  $3\% \pm 1\%$  slope away from the precast modular block wall face and compact it.
  
- E. The General Contractor shall direct the Grading Contractor to protect the precast modular block wall structure against surface water runoff at all times through the use of berms, diversion ditches, silt fence, temporary drains, and/or any other necessary measures to prevent soil staining of the wall face, scour of the retaining wall foundation, or erosion of the reinforced backfill or wall infill.

### 3.06 OBSTRUCTIONS IN THE INFILL AND REINFORCED FILL ZONE

- A. The Retaining Wall Installation Contractor shall make all required allowances for obstructions behind and through the wall face in accordance with the approved construction shop drawings.
  
- B. Should unplanned obstructions become apparent for which the approved construction shop drawings do not account, the effected portion of the wall shall not be constructed until the Retaining Wall Design Engineer can appropriately address the required procedures for construction of the wall section in question.

### 3.07 COMPLETION

- A. For walls supporting unpaved areas, a minimum of 12 inches (305 millimeters) of compacted, low-permeability fill shall be placed over the granular wall infill zone of the precast modular block retaining wall structure. The adjacent retained soil shall be graded to prevent ponding of water behind the completed retaining wall.
  
- B. For retaining walls with crest slopes of 5H:1V or steeper, a silt fence shall be installed along the wall crest immediately following construction. The silt fence shall be located 3-to-4 feet (0.9 -to-1.2 meters) behind the uppermost precast modular block unit. The crest slope above the wall shall be immediately seeded to establish vegetation. The General Contractor shall ensure that the seeded slope receives adequate irrigation and erosion protection to support germination and growth.
  
- C. The General Contractor shall confirm that the as-built precast modular block wall geometries conform to the requirements of this section. The General Contractor shall notify the Owner of any deviations.

**END OF SECTION 32 32 16**







# INSTALLATION GUIDE

# 1. PURPOSE

This manual is intended to serve as a guide for the proper installation and construction of a Redi-Rock® retaining wall. The recommendations and guidelines presented here are intended to supplement detailed construction documents, plans, and specifications for the project.

# 2. RESPONSIBILITIES

Redi-Rock supports a Total Quality Management approach to Quality Assurance and Quality Control (QA/QC) in the planning, design, manufacture, installation, and final acceptance of a Redi-Rock wall. This approach requires the responsible party at each stage of the project ensure that proper procedures are followed for their portion of the work. The responsible parties during the construction phase of a Redi-Rock wall include the Contractor, Engineer or Owner's Representative, and Redi-Rock licensed manufacturer. Their specific responsibilities for compliance are as follows:

## CONTRACTOR

The Contractor is responsible for providing construction according to the contract documents, plans, and specifications for the project. The Contractor shall ensure that employees engaged in construction of the Redi-Rock wall understand and follow the project plans and specifications, are familiar with construction methods required, and have adequate safety training.

## ENGINEER OR OWNER'S REPRESENTATIVE

The Engineer or Owner's Representative is responsible for construction review to assure that the project is being constructed according to the contract documents (plans and specifications). The representative shall fully understand the project plans and specifications and shall perform adequate field verification checks to ensure construction is in conformance with the project requirements. The presence of the Engineer or Owner's representative does not relieve the Contractor of their responsibilities for compliance with the project plans and specifications.

## REDI-ROCK LICENSED MANUFACTURER

Redi-Rock blocks are produced by independently-owned licensed manufacturers. The manufacturer is responsible for the production and delivery of Redi-Rock units to the job site in accordance with published material quality, size tolerances, construction documents, plans, and specifications. The licensed manufacturer is responsible for adherence to any project specific QA/QC requirements for the production of precast concrete retaining wall units. Often, additional services—such as installation training classes—are available through the Redi-Rock manufacturer.

## 3. PRE-CONSTRUCTION CHECKLIST

Before you start construction of a Redi-Rock wall, take the time to complete necessary planning and preparation. This process will help ensure a safe, efficient, and quality installation. It will also help avoid costly mistakes.

### SAFETY

**Safety is of primary concern to Redi-Rock International.** Redi-Rock walls must be installed in a safe manner. All local, state, and federal safety regulations must be followed. In addition, Redi-Rock International greatly encourages installers to set up company programs to help their people stay safe at work. These programs should address items such as: personal protective equipment, maintaining safe slopes and excavations, fall protection, rigging and lifting, and other safety precautions. Safety-training materials specific to your company can be found at [www.osha.gov](http://www.osha.gov), by calling 1-800-321-OSHA (6742), or from your local government safety office.

### ENGINEERING AND PERMITS

Obtain necessary engineering and permits for your project. Your local building department is an excellent resource to help determine the requirements for your project.

**This installation guide is intended to supplement a detailed, site-specific wall design prepared for your project by a Professional Engineer. The construction documents for your project supersede any recommendations presented here.**

### REVIEW THE PROJECT PLANS

Take the time to review and understand the project plans and specifications. Make sure that the plans take into account current site, soil, and water conditions. Pay close attention to silty or clayey soils and ground water or surface water on the site as these can significantly increase the forces on the wall. A pre-construction meeting with the wall design engineer, construction inspector, wall contractor, and owner or representative is recommended.

### CONSTRUCTION PLANNING

Develop a plan to coordinate construction activities on your site. Make sure your plan specifically addresses how to control surface water during construction.

### UTILITY LOCATION

Make sure to have underground utilities located and marked on the ground before starting any construction. Call 8-1-1, go online to [www.call811.com](http://www.call811.com), or contact your local utility company to schedule utility marking for your project site.

## □ MATERIAL STAGING

Store Redi-Rock blocks in a location close to the proposed wall. Blocks should be kept clean and mud free. Blocks should also be stored in a location which will minimize the amount of handling on the project site.

Store geogrid in a clean, dry location close to the proposed wall. Keep the geogrid covered and avoid exposure to direct sunlight.

Be careful where you stockpile excavation and backfill material. Do not stockpile material over buried utility pipes, cables, or near basement walls which could be damaged by the extra weight.

## □ MATERIAL VERIFICATION

Material planned for use as drainage aggregate between and behind Redi-Rock blocks and structural backfill material proposed for use in the reinforced soil zone of mechanically stabilized earth walls must be inspected and verified to comply with requirements of the construction documents, plans, and specifications.

## □ EQUIPMENT

Make sure you have the proper equipment to handle Redi-Rock blocks and install the wall. Redi-Rock blocks are quite large and heavy. Make sure excavators and other construction equipment are properly sized to handle the blocks safely. **(Figure 1)**

Hand-operated equipment should include, at a minimum: shovels, 2-foot (0.6-meter) level, 4-foot (1.2-meter) level, broom, hammer, tape measure, string, spray paint, laser level, pry or Burke bar, walk-behind vibratory plate compactor (capable of delivering a minimum of 2000 lb (8.9 kN) centrifugal force), and a 16-inch (406-millimeter) concrete cut-off saw. **(Figure 2)**

Personal protective equipment should include, at a minimum: appropriate clothing, steel toe boots with metatarsal protection, eye protection, hard hat, gloves, hearing protection, fall protection rigging, and other items as necessary to ensure a safe working environment.



Figure 1



Figure 2

## 4. SUBGRADE SOILS

Proper base preparation is a critical element in the construction of your retaining wall. Not only is it important to provide a stable foundation for the wall, but a properly prepared base will greatly increase the speed and efficiency of your wall installation. Proper base preparation starts with the subgrade soils.

Existing soils must be removed to the bottom of the leveling pad elevation for the retaining wall.

The base and back of excavation should expose fresh, undisturbed soil or rock. Remove all organic, unsuitable, and disturbed soils that “fall-in” along the base of the wall or the back of the excavation. Always provide safe excavations in accordance with OSHA requirements.

The subgrade soil (below the leveling pad) should be evaluated by the Engineer or Owner’s Representative to verify that it meets the design requirements and to determine its adequacy to support the retaining wall. Any unsuitable material shall be excavated and replaced as directed by the on-site representative and per the requirements of the contract drawings, plans, and specifications.

Subgrade soils must be compacted to a density as specified in the contract documents, plans, and specifications but not less than 90% maximum density at  $\pm 2\%$  optimum moisture content as determined by a modified proctor test (ASTM D1557). **(Figures 3 and 4)**

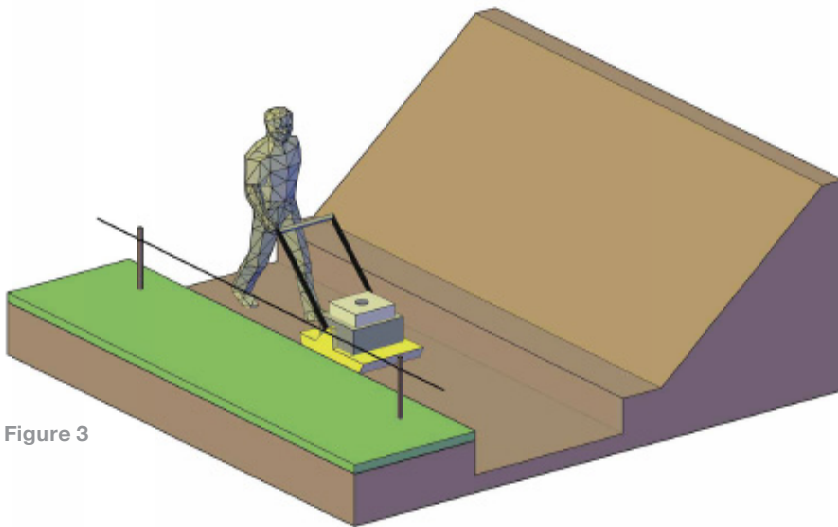

Figure 3

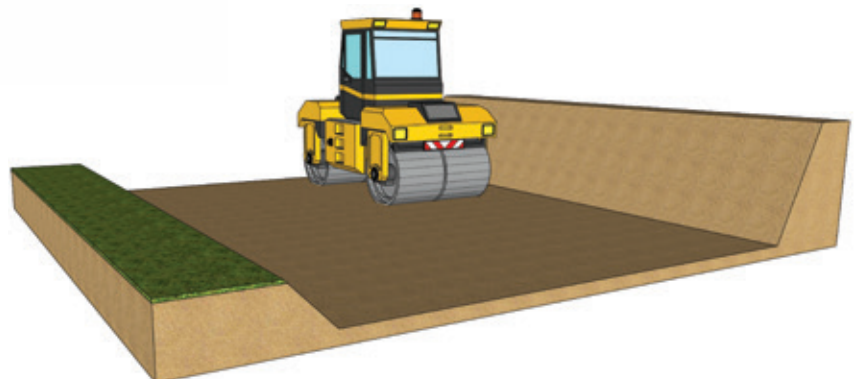

Figure 4

## 5. LEVELING PAD

Base preparation continues with proper leveling pad construction. Redi-Rock retaining walls can be designed with an open-graded crushed stone, dense-graded crushed stone (GAB), or concrete leveling pad which supports the bottom row of blocks. The choice of which type of leveling pad to use is made by the wall design engineer and depends on several factors including the bearing capacity of the native soil, location of the drain outlet, and conditions at the base of the wall.

Open-graded crushed stone is typically used in cases where the wall drain can outlet to daylight (by gravity) somewhere below the elevation of the bottom of the leveling pad. **(Figure 6A)** The material should be 1-inch (25-millimeter) diameter and smaller stone. A crushed stone meeting the gradation requirements of ASTM No. 57 with no material passing the No. 200 (74  $\mu\text{m}$ ) sieve is preferred. The leveling pad thickness shall be as designed by the wall design engineer. A minimum thickness of 6 inches (152 millimeters) or 12 inches (305 millimeters) is common. The leveling pad should extend at least 6 inches (152 millimeter) in front and 12 inches (305 millimeters) behind the bottom block. Make sure to check your construction documents for details.

Dense-graded crushed stone or graded aggregate base (GAB) material is typically used in cases where the wall drain can only outlet to daylight somewhere above the bottom of the leveling pad. **(Figure 6B)** The material should be dense-graded crushed stone with between 8 and 20% “fines” which will pass through a No. 200 (74  $\mu\text{m}$ ) sieve. The leveling pad thickness shall be as designed by the wall design engineer. Minimum dimensions are the same as those for an open-graded crushed stone leveling pad.

The leveling pad material should be placed and compacted to provide a uniform, level pad on which to construct the retaining wall. **(Figure 5)** Proper elevation can be established with a laser level or transit. You can also set two 20' (6 m) long grade (screed) pipes to the desired grade and screed the crushed stone material between the pipes.



Figure 5

Place the stone leveling pad in uniform loose lifts a maximum of 6 inches (152 millimeter) thick. Consolidate the stone with a minimum of three passes with a 24-inch (610-millimeter) wide walk-behind vibrating plate compactor capable of delivering at least 2000 pounds (8.9 kN) of centrifugal force. This should achieve 85% relative density of the stone determined in accordance with ASTM D-4253 and D-4254. In place density of the stone fill should be confirmed using ASTM D-6938. If you don't achieve a minimum of 85% relative density, place the stone in smaller lifts or apply more compaction effort until you do achieve desired density of the stone.

Unless specifically included in the design calculations, do NOT place a thin layer of sand between the leveling pad and bottom block. This layer will reduce the sliding resistance between the leveling pad and bottom block.

In some cases, the wall design requires the construction of a concrete leveling pad. **(Figures 6C and 6D)** Construct the leveling pad according to the detailed plans for your project.

Some designs require a shear key in the bottom of the footing and/or a lip in front of the Redi-Rock blocks. These items would be shown in the project plans.

If steel rebar is to be placed in the footing, secure the bars together with wire ties in the pattern shown in the construction documents. Use rebar supports to hold the rebar structure in the proper position in the footing.

Place wood formwork at the front and back of the concrete leveling pad or footing. The top of the formwork should be placed at the elevation of the top of the concrete footing so you can screed the top smooth in preparation for block placement. It is important that the top surface be smooth and level for full contact of the retaining wall blocks. Place concrete as specified in the wall design. Once the concrete has been allowed to cure to the minimum specified strength, place the bottom blocks and continue construction of the retaining wall.

Figure 6

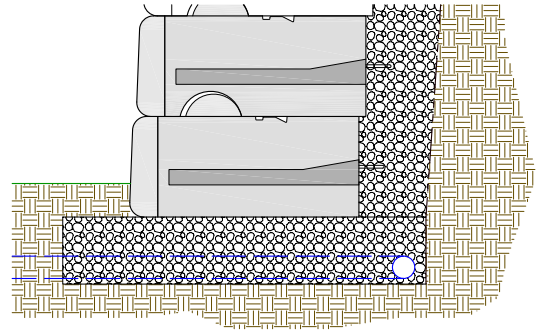

A. Open Graded Stone Leveling Pad

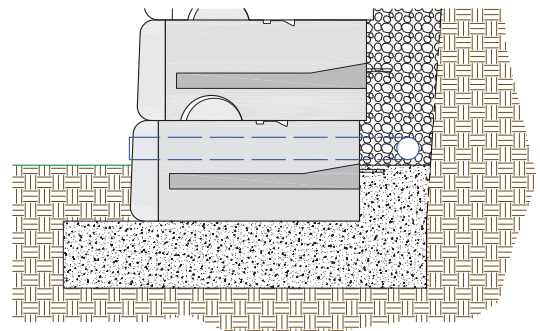

B. Dense Graded Stone Leveling Pad

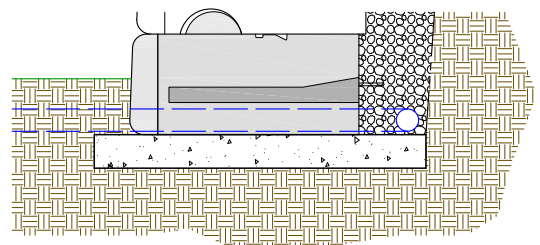

C. Lean Concrete Leveling Pad

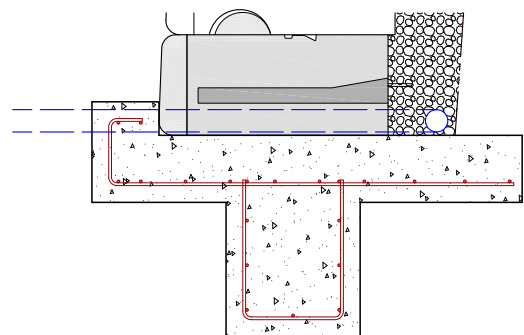

D. Reinforced Concrete Leveling Pad

## 6. SETTING THE BOTTOM ROW OF WALL BLOCKS

Redi-Rock blocks are typically delivered to the construction site using a flatbed trailer or boom truck. **(Figure 7)** Rubber tired backhoes, loaders, skid steers, or excavators are used to set the retaining wall blocks. **(Figure 8)** Make sure to use the proper sized equipment to handle the large blocks. All lifting chains, rigging, or slings must be OSHA compliant and safety rated for proper working loads.

Properly mark the location of the retaining wall. A string line or offset stakes are typically used to establish horizontal and vertical alignment. If offset stakes are used, the stakes should be placed at least 5 feet (1.5 meters) but no more than 10 feet (3 meters) in front of the face of the retaining wall. A stake should be provided at every elevation change and at a maximum of 50 feet (15 meters) apart.

**Wall construction should start at a fixed point such as a building wall, 90° corner, or at the lowest elevation of the wall.**

Place the blocks on the prepared leveling pad. Blocks shall be placed in full contact with the leveling pad and other immediately adjacent block units. **(Figure 9)** Block alignment should be established by lining up the “form line” where the face texture meets the steel form finished area at the top of the block, approximately 5 inches (127 millimeters) back from the front face. **(Figure 10)**

Check all blocks for level and alignment as they are placed. Small adjustments to the block location can be made with a large pry or Burke bar. Proper installation of the bottom block course is critical to maintaining the proper installation of all subsequent block courses within acceptable construction tolerance. It also makes installation of the upper rows of blocks much easier and more efficient.

Place and compact backfill in front of the bottom block course prior to placement of subsequent block courses or backfill. This will keep the blocks in place as drainage aggregate and backfill are placed and compacted.



Figure 7



Figure 8

Place an 18 inch x 12 inch (457 millimeter x 305 millimeter) piece of non-woven geotextile fabric in the vertical joint between the blocks to prevent the drainage aggregate and backfill material from migrating through the vertical joints between blocks. **(Figure 11)**

Place washed drainstone or open-graded crushed stone backfill between blocks and at least 12 inch (305 millimeter) behind the wall. A stone meeting the gradation requirements of ASTM No. 57 with no material passing the No. 200 (74  $\mu$ m) sieve is preferred. Place the stone in uniform loose lifts a maximum of 6 inches (157 millimeter) thick. Consolidate the stone with a minimum of three passes with a 24-inch (610 millimeter) wide, walk-behind, vibrating plate compactor capable of delivering at least 2000 lb (8.9 kN) of centrifugal force. **(Figure 12)** This should achieve 85% relative density of the stone determined in accordance with ASTM D-4253 and D-4254. In place density of the stone fill should be confirmed using ASTM D-6938. If you don't achieve a minimum of 85% relative density, place the stone in smaller lifts or apply more compaction effort until you do achieve desired density of the stone.

Place non-woven geotextile fabric between the drainstone and the remaining backfill material if specified.

Backfill behind the drainage aggregate with material as specified in the project construction documents. Place the lifts as specified, but not to exceed 9 inches (229 millimeter) maximum. Granular backfill shall be compacted to a minimum of 90% maximum density at  $\pm$  2% optimum moisture content as determined by a modified proctor test (ASTM D1557). Use proper equipment to insure complete compaction of the backfill material. It may be necessary to wet or dry the backfill material, place the material in smaller lifts, and/or apply more compaction effort to reach 90% maximum density. Do not use any organic, topsoil, frozen, soft, wet, or loose soils when backfilling the wall.

Re-check all units for level and alignment and sweep the top of each course of blocks clean before starting construction of the next course.

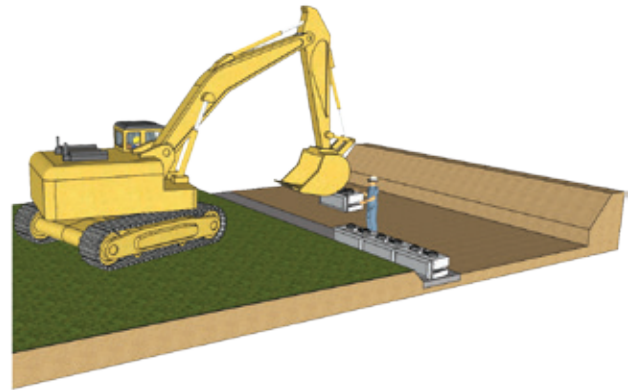

Figure 9

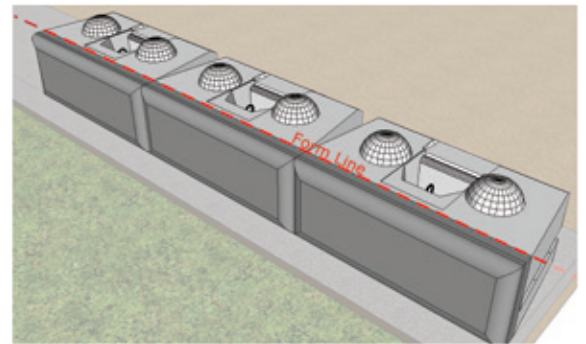

Figure 10

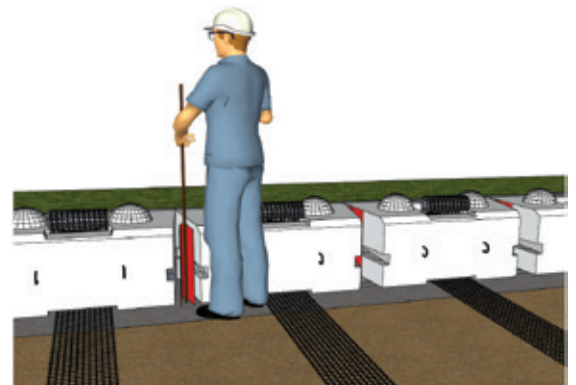

Figure 11



Figure 12

## 7. INSTALLING THE WALL DRAIN

A drain is placed behind the Redi-Rock wall blocks at the lowest elevation where the pipe can safely outlet to daylight. Drainage aggregate should be placed to the bottom of the drain as shown in the construction documents. A 4-inch (102 millimeter) perforated sock drain is commonly used for the drain pipe. Often the drain is encapsulated with drainage aggregate and wrapped with a non-woven geotextile fabric. The drain should run the entire length of the wall and needs to have proper outlets on the ends and at regularly spaced points along the wall. Solid pipe should be used for weep hole outlets through the face or under the retaining wall. **(Figure 13)**

Care needs to be taken during installation to avoid crushing or damaging the drain pipe or outlets.

## 8. SETTING UPPER ROWS OF WALL BLOCKS

Once the backfill is fully placed and compacted for the block course below, place the next row of blocks in a running bond configuration with the vertical joint of the lower block units centered under the mid-point of the block units above. If needed, a half block can be used at the end of every other row to maintain a running bond. **(Figure 14)**

Push the Redi-Rock blocks forward until the groove on the bottom of the block comes in full contact with the knobs on the blocks below. Adjacent blocks shall be placed with their front edges tightly abutted together.

Place non-woven geotextile fabric in the vertical joint between the blocks, and place and compact the drainage aggregate and backfill material the same way you did for the bottom row.

Never install more than one course of blocks without placing and compacting drainage aggregate and backfill to the full height of the block units. Placing multiple courses of blocks without backfill will prevent the proper placement and consolidation of the drainage aggregate between the blocks.

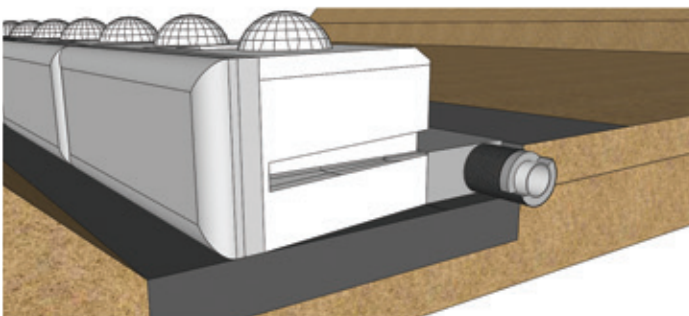

Figure 13

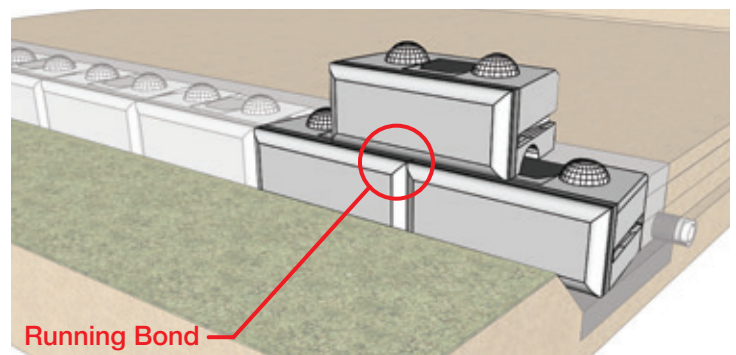

Figure 14

## 9. INSTALLING GEOGRID FOR MECHANICALLY STABILIZED EARTH WALLS

Redi-Rock blocks are designed to allow you to build relatively tall non-reinforced (or gravity) walls which use the weight of the blocks to provide stability. However, for some projects you may need to build even taller walls. In these cases, mechanically stabilized earth (MSE) retaining walls can be built with the Redi-Rock Positive Connection (PC) System.

The geogrid used in Redi-Rock PC System walls are 12-inch (305-millimeter) wide strips of PVC coated polyester geogrid that wrap through a vertical core slot cast into the block and extend full length into the reinforced soil zone on both the top and bottom of the block.

**It is critical that you only use factory cut strips of Mirafi geogrid that are certified by TenCate Mirafi for width and strength. Field cutting strips of geogrid from larger rolls can significantly degrade the capacity of the wall system and is not allowed. Geogrid strips are only available through a Redi-Rock Manufacturer. (Figure 15)**

Verify that you have the correct geogrid material and then cut the individual strips to the required length. The distance a geogrid strip must extend into the reinforced soil zone (design length) is measured from the back of the block to the end of the geogrid. Since the geogrid wraps through the block, the actual cut length of a given geogrid strip is two (2) times the design length plus enough additional geogrid to wrap through the block. For the Redi-Rock 28-inch (710-millimeter) PC blocks, the cut length is two (2) times the design length plus 3 feet (0.9 meters).



Figure 15

Inspect the Redi-Rock PC blocks for any concrete flashing or sharp edges in the slot and groove through the block. Remove any flashing and grind smooth any sharp edges which could damage the geogrid reinforcement.

Place the geogrid strip in the vertical core slot from the bottom of the block and pull approximately half of the length of the strip up through the core slot. Measure from the back of the block unit to the required design length and pin the bottom leg of the geogrid strip with staples, stakes, or other appropriate methods. Pull the geogrid strip tight to remove any slack, wrinkles, or folds. Secure the geogrid firmly in place by putting a pin through the geogrid and the steel lifting insert which is located in the recessed area on the top of the PC block (Figure 16) or placing drainage aggregate in the vertical core slot.

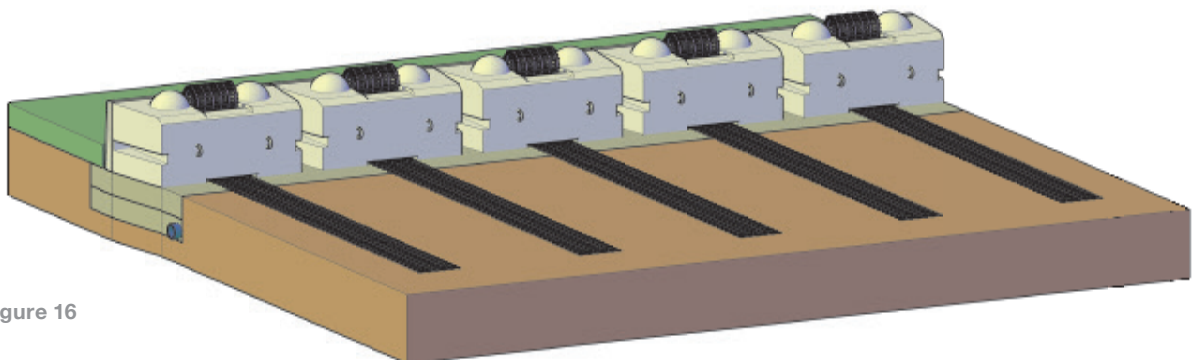

Figure 16

Place drainage aggregate between and behind the blocks. **(Figure 17)** Place the stone in uniform loose lifts as required in the project plans and specifications. Consolidate the stone between the blocks by hand tamping. Make sure to tamp stone into the ends of the groove on the bottom of the Redi-Rock PC blocks. Consolidate the stone behind the blocks with a minimum of three passes with a 24-inch (610-millimeter) wide walk-behind vibrating plate compactor capable of delivering at least 2000 lb (8.9 kN) of centrifugal force. Provide further compaction if needed to meet the density specified in the contract documents, but not less than 85% relative density of the stone determined in accordance with ASTM D-4253 and D-4254.

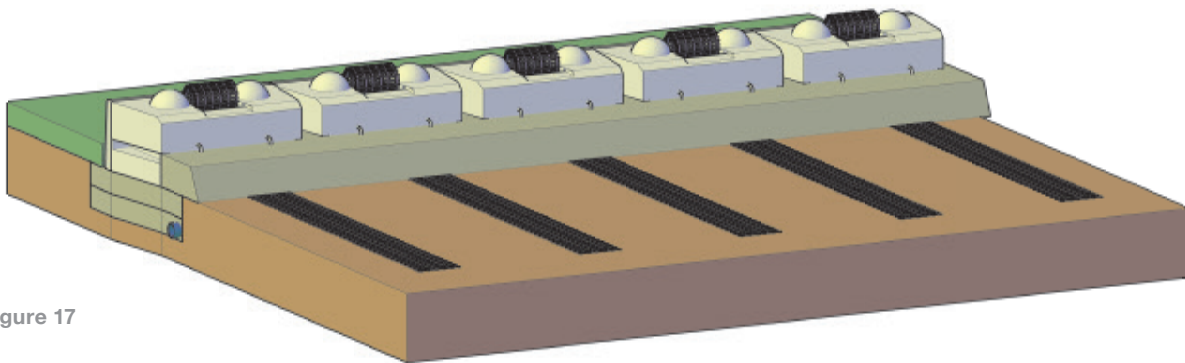

Figure 17

Place a strip of non-woven geotextile fabric between the drainage aggregate and the reinforced soil zone if specified.

Place the reinforced soil zone material in uniform loose lifts as required in the project plans and specifications. Reinforced soil zone material must be compacted to a density as specified in the contract documents, plans, and specifications but not less than 90% maximum density as determined by a modified proctor test (ASTM D1557).

Begin compaction at the back of the wall blocks and proceed to the embedded end of the geogrid strip using care to maintain the reinforcement strip in a level, taut condition oriented perpendicular to the back of the block unit to which it is attached.

Use hand operated compaction equipment within 3 feet (1 meter) of the back of the PC blocks. Heavier equipment can be used beyond 3 feet (1 meter) away from the PC blocks. Tracked construction equipment must not be operated directly on the geogrid strip reinforcement. A minimum fill thickness of 6 inches (150 millimeter) is required for the operation of tracked vehicles over the geogrid strips. Turning of tracked vehicles should be kept to a minimum to prevent displacement of the fill and the geogrid strips. Rubber-tired vehicles may pass over the geogrid strips at a slow speed of less than 5 mph (8 km/hr). Sudden braking and sharp turning should be avoided.

After placing and properly compacting backfill to the elevation of the geogrid strip at the top of the block, extend the top leg of the geogrid strip to the design length required. Pull the geogrid strip tight to remove any slack, wrinkles, or folds. **(Figure 18)** Pin the top leg of the geogrid strip with staples, stakes, or other appropriate methods to hold it in place and keep the geogrid strip taut.

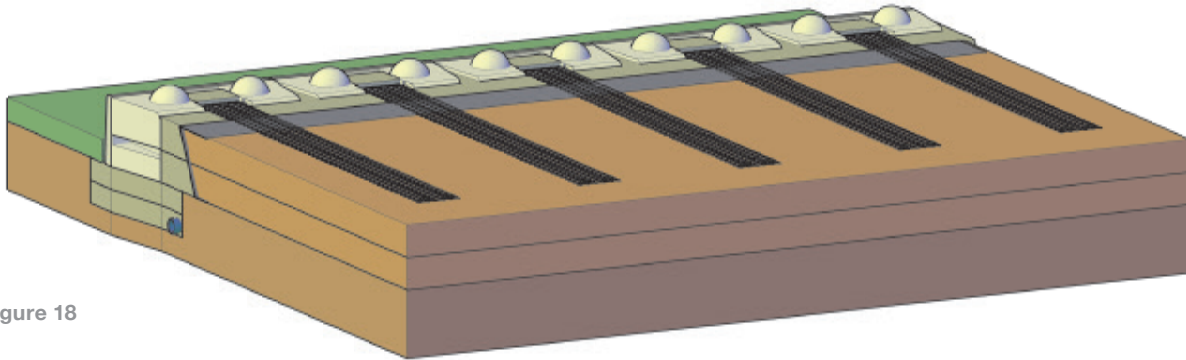

Figure 18

Fill the center slot in the PC blocks with drainage aggregate. Be careful to keep the grid flat against the back of the slot in the PC block and prevent any stone from lodging between the geogrid and the concrete block. Fill the vertical core slot completely with drainage aggregate. Consolidate the drainage aggregate by hand tamping. Use a broom to sweep clean the top of the blocks. Do not operate a walk behind vibratory plate compactor on top of the Redi-Rock PC blocks.

Place retained soil immediately between the end of the reinforced soil zone (identified as the embedded end of the geogrid reinforcement strips) and the back of the excavation. Compact retained soil to a density as specified in the contract documents, plans, and specifications but not less than 90% maximum density at  $\pm 2\%$  optimum moisture content as determined by a modified proctor test (ASTM D1557). Maximum differential elevation between the reinforced fill and the retained soil fill should never exceed 18 inches (457 millimeters).

Continue construction in a similar fashion to the top of the wall. **(Figure 19)**

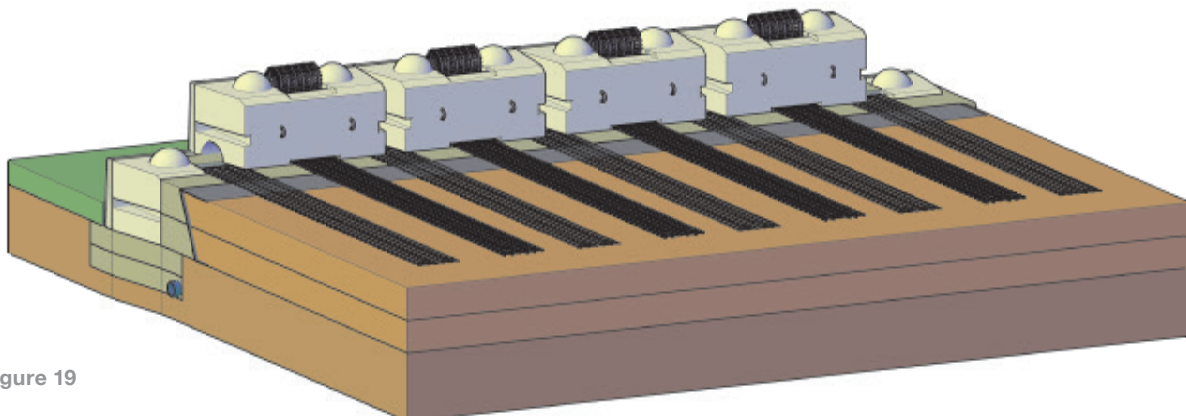

Figure 19

# 10. SPECIAL FEATURES

Some walls require special features such as curves, corners, top of wall details, drains in areas with elevated groundwater, and other details. **(Figures 21-23)** Refer to the construction documents, plans, and specifications to construct these features. Additional guides and common construction details are available at [redi-rock.com](http://redi-rock.com).



Figure 21



Figure 22



Figure 23

# 11. IMPORTANT NOTES

Best practice dictates that wall construction should continue without interruption or delays. This will help expedite construction and minimize the time the excavation is open.

The construction site should be graded and maintained to direct surface water runoff away from the retaining wall throughout the entire construction process.

Do not exceed the allowable construction tolerances specified in the contract documents, plans, and specifications. At no time should tolerances at the wall face exceed 1° vertically and 1 inch in 10 feet (25.4 millimeters in 3048 millimeters) (1:120) horizontally.

Immediately report the following site conditions, if encountered, to the Engineer or Owner's representative to determine the corrective action needed:

- Any observed groundwater seepage.
- Surface water run-off directed toward the retaining wall during construction.
- Erosion or scour of material near the wall.
- Ponded water near the wall.
- Wet, soft, or easily compressible soils in the foundation zone.
- Existing rock that differs in location from that shown on the project plans or rock located above the elevation of the bottom of the leveling pad.
- Existing or proposed toe or crest slopes that differ from typical cross-sections shown in the project plans.
- Any other items not specifically mentioned which raise questions or cause concerns during wall construction.

**Immediately implement any corrective action before resuming wall construction.**

## 12. FREESTANDING WALLS

Redi-Rock freestanding wall blocks have facing texture on two or three sides. They are used in applications where two or three sides of the wall are visible. Freestanding blocks can be installed as “stand alone” walls, such as perimeter walls or fences. They can also be designed and installed as the finishing top courses on a Redi-Rock retaining wall.

Freestanding wall installation is similar to that for Redi-Rock retaining walls. The main exception is that there is typically no backfill material behind the freestanding walls. Even though there is no backfill acting on the walls, freestanding walls need to be properly engineered. They require adequate stability at the base of the wall and they need to resist any applied forces such as wind loads or forces from railings or fences.

If you are building a “stand alone” freestanding wall, prepare the subgrade soils and leveling pad as described previously. Place bottom blocks on the leveling pad. A 6 inch (152 millimeter) minimum bury on the bottom block is typical. Extra bury may be required for some projects. Middle and top blocks are placed directly on top of the bottom blocks with no batter.

If you are building a freestanding wall on the top of a Redi-Rock retaining wall, end the last row of retaining wall blocks with a middle block. The size of the knob on top of the last row of retaining wall blocks will establish the setback for the first row of freestanding blocks. Retaining blocks with a 10-inch (254-millimeter) diameter knob will produce a 2 7/8 inch (73 millimeter) setback between the retaining block and the first freestanding block. If the retaining blocks have a 7 ½ inch (190 millimeter) diameter knob, the setback between the retaining block and the first freestanding block will be 1 5/8 inches (41 millimeters). Be sure to contact your local Redi-Rock manufacturer to determine availability of blocks with different knob sizes.

Begin and end freestanding walls with full or half Corner blocks.

Freestanding walls are installed plumb with no batter.



Figure 24

Variable radius freestanding blocks with a 4 inch x 12 inch (102 millimeter x 305 millimeter) pocket in one or two ends of the block are used to make curved walls. Field cut the relatively thin face texture on the ends of the variable radius blocks as needed to make the desired radius for your wall. **(Figure 24)**

Colored foam “Backer Rod” can be used to fill any small gaps which may occur between the blocks when installing walls. Backer rods can be purchased from concrete supply centers. Call your local Redi-Rock manufacturer for help locating foam backer rods for your project.

# 13. CAP INSTALLATION

Cap or step blocks are commonly used on top of freestanding walls to provide a finished look. **(Figure 25)**

Mark the center of the freestanding blocks to monitor the correct running bond spacing.

Secure the cap with construction adhesive, polyurethane sealant, or mortar. If construction adhesive is used, it should meet the requirements of ASTM D3498 and C557 and HUD/FHA Use of Materials Bulletin #60. Two examples are Titebond Heavy Duty Construction Adhesive by Franklin International or PL Premium Construction Adhesive. If polyurethane sealant is used, it should be one-component, highly-flexible, non-priming, gun-grade, high-performance elastomeric polyurethane sealant with movement of  $\pm 25\%$  per ASTM C719, tensile strength greater than 200 psi (1.4 MPa) per ASTM D412, and adhesion to peel on concrete greater than 20 PLI per ASTM C794.

Adhesive or sealants should be applied in 1.5 inch (38 millimeter) diameter round “Hershey Kiss” shaped dollops located in two rows at the top of the freestanding blocks at 8 inches (203 millimeter) on center.

Caps can be cut as needed for proper alignment. If desired, grout the joints between cap blocks after installation with a non-shrink grout.



Figure 25

# 14. FORCE PROTECTION WALLS

Install a threaded termination end on the end of the cable. Electroline M Series terminations manufactured by *Esmet, Inc.* work well.

Thread cable with a termination end through all the blocks. It is important that the cable is placed in each course of blocks prior to placing the next course.

Pull the cable through the block on the far end of the wall until approximately 2 inches (51 millimeters) of threads protrude beyond the end of the blocks. The exposed threads will provide room to place for a 5/8 inch x 6 inch x 9 inch (16 millimeter x 152 millimeter x 229 millimeter) steel plate over the exposed threads and start the nut.

Mark and cut the cable at the starting end of the wall so that 4 inches (102 millimeter) of cable protrudes beyond the block, providing room a 5/8 inch x 6 inch x 9 inch (16 millimeter x 152 millimeter x 229 millimeter) steel plate and ferrule termination fitting.

After the cable has been cut, slide the entire cable several feet (meters) towards the ferrule end so that you will have room to work. Install a steel plate and ferrule termination end on the cable.

Pull the cable snug so that the ferrule is against the steel plate. There will be 2 inches (51 millimeters) of thread exposed at the far end of the wall which has the termination end on the cable.

Place the steel plate over the threads and start the nut. The nut can be tightened to the desired tension.

## Force Protection Coping With J-Bolts and Post-Tensioned Cable

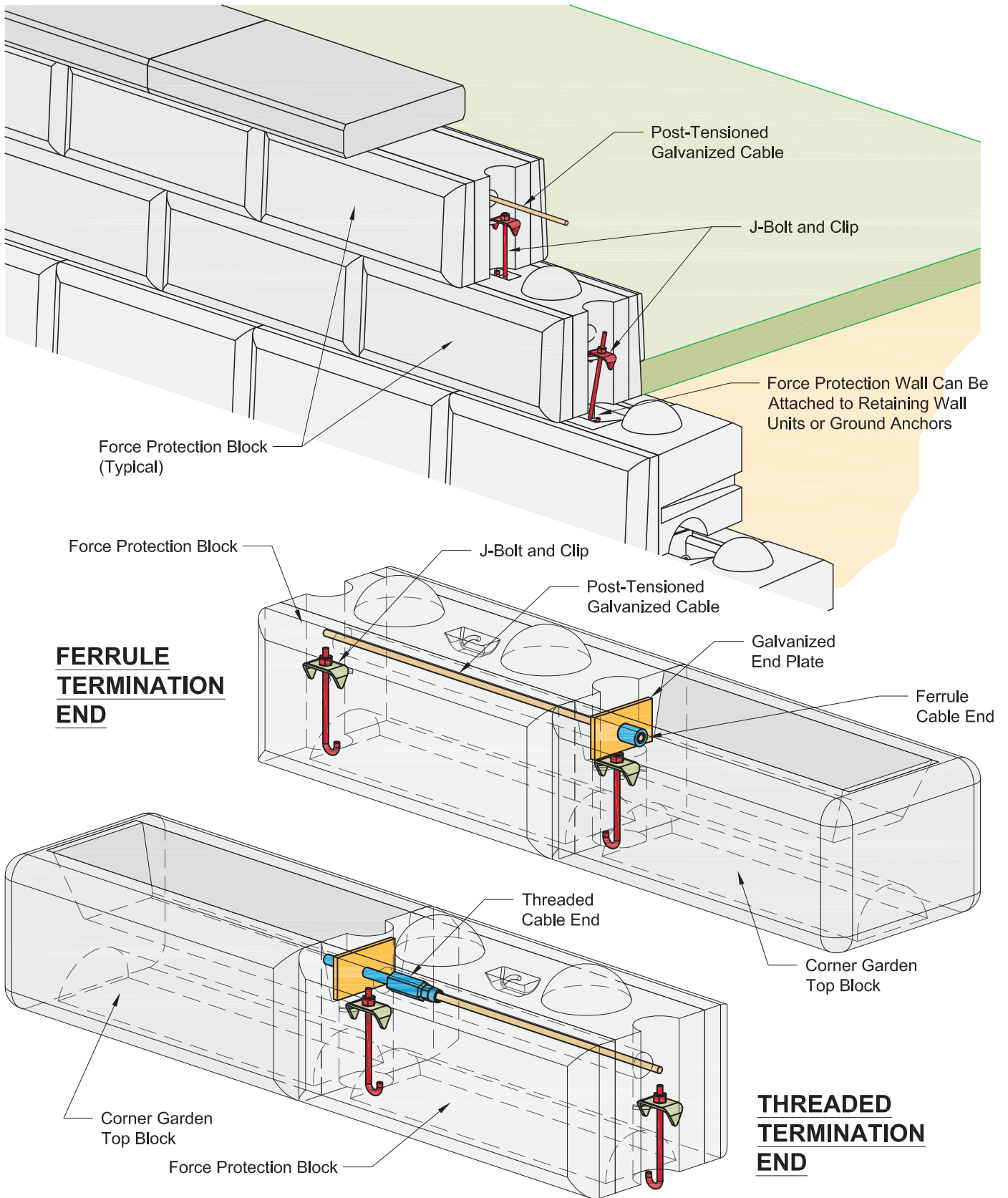

- This drawing is for reference only.
- **Final designs for construction must be prepared by a registered Professional Engineer** using the actual conditions of the proposed site.
- **Final wall design must address both internal and external drainage and shall be evaluated by the Professional Engineer who is responsible for the wall design.**

## Force Protection Coping With J-Bolts

- This detail can be installed with either a single or multiple rows of Force Protection blocks.
- J-Bolts and clips are used to connect the top row of retaining blocks and all Force Protection blocks together.
- J-Bolt installation is not intended for traffic impact loads.
- Force Protection blocks can be attached to retaining wall blocks or ground anchors.

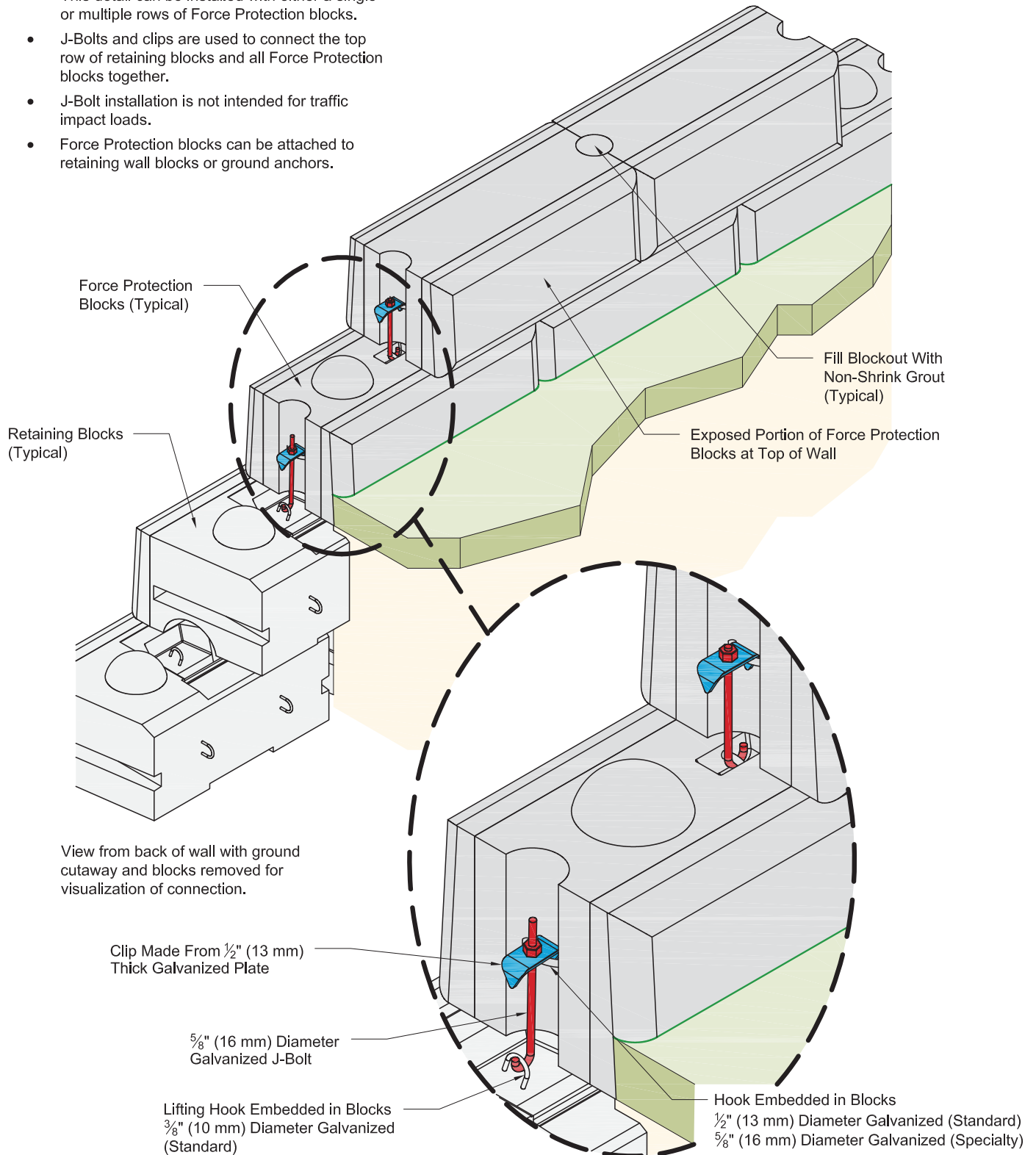

- *This drawing is for reference only.*
- **Final designs for construction must be prepared by a registered Professional Engineer** using the actual conditions of the proposed site.
- **Final wall design must address both internal and external drainage and shall be evaluated by the Professional Engineer who is responsible for the wall design.**

## J-BOLT INSTALLATION

J-Bolts can be used to secure force protection walls to the top row of retaining wall blocks (when used on the top of a Redi-Rock wall) or to concrete anchors set in the ground (for a stand alone wall).

Set force protection blocks with the ends centered on ground anchors or the center of Redi-Rock middle retaining wall blocks immediately below.

Place a clip between blocks in hooks provided in the middle of the block on each end.

Place a J-bolt through center of the clip, thread a nut on the J-bolt, and tighten.

Repeat for all remaining courses of force protection blocks.

# 15. REDI-ROCK COLUMNS

Redi-Rock column blocks are available to complement Redi-Rock walls. Columns can be installed by themselves or with fences or gates.

Column blocks can be placed on properly prepared aggregate or concrete leveling pads or directly on Redi-Rock retaining wall blocks, depending on the specific design for your project.

Column blocks can be manufactured with pockets for concrete or split wood fence rails.

Concrete adhesive or polyurethane sealant can be used between stacked column blocks.

Install a cap on the top of a column. Adjust the cap position until all sides are equidistant and square to the column. Secure the column cap with construction adhesive or polyurethane sealant.

Special inserts are available for mounting gates or similar features to Redi-Rock columns.

Column blocks are available with 4 inch (102 millimeter) or tapered 8 inch (203 millimeter) diameter cores which can be filled with stone or concrete and steel rebar reinforcement.

A conduit can be left through the core if needed for lighting or other features.







# CONSTRUCTION DETAILS

### Typical Gravity Wall Section

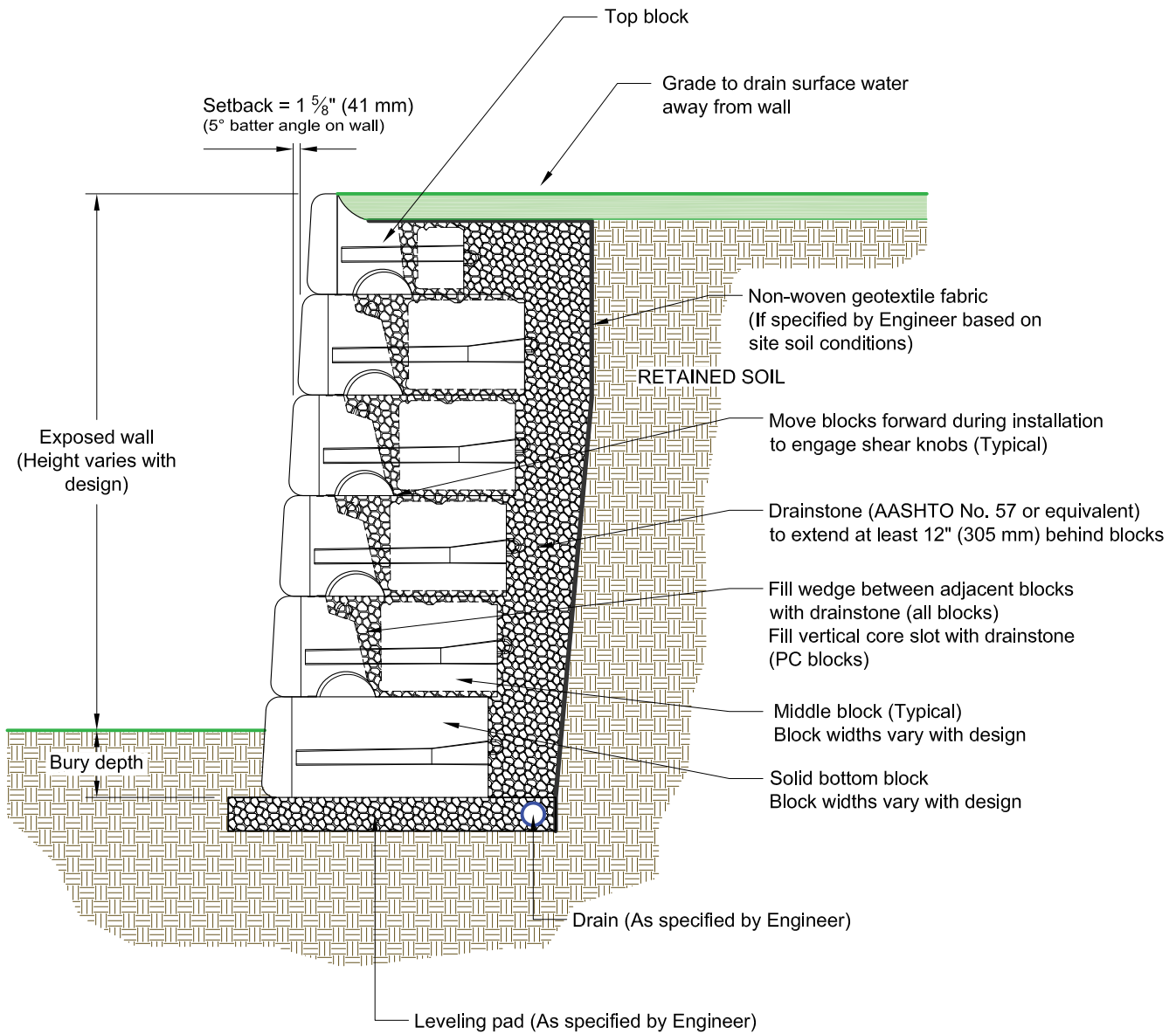

This drawing is for reference only. Determination of the suitability and/or manner of use of any details contained in this document is the sole responsibility of the design engineer of record. Final project designs, including all construction details, shall be prepared by a licensed professional engineer using the actual conditions of the proposed site.

### Typical Reinforced Wall Section

**Note:**

One degree or zero degree batter angle walls are available using blocks with 7 1/2" (190 mm) or 6 3/4" (171 mm) knobs (Specialty items)

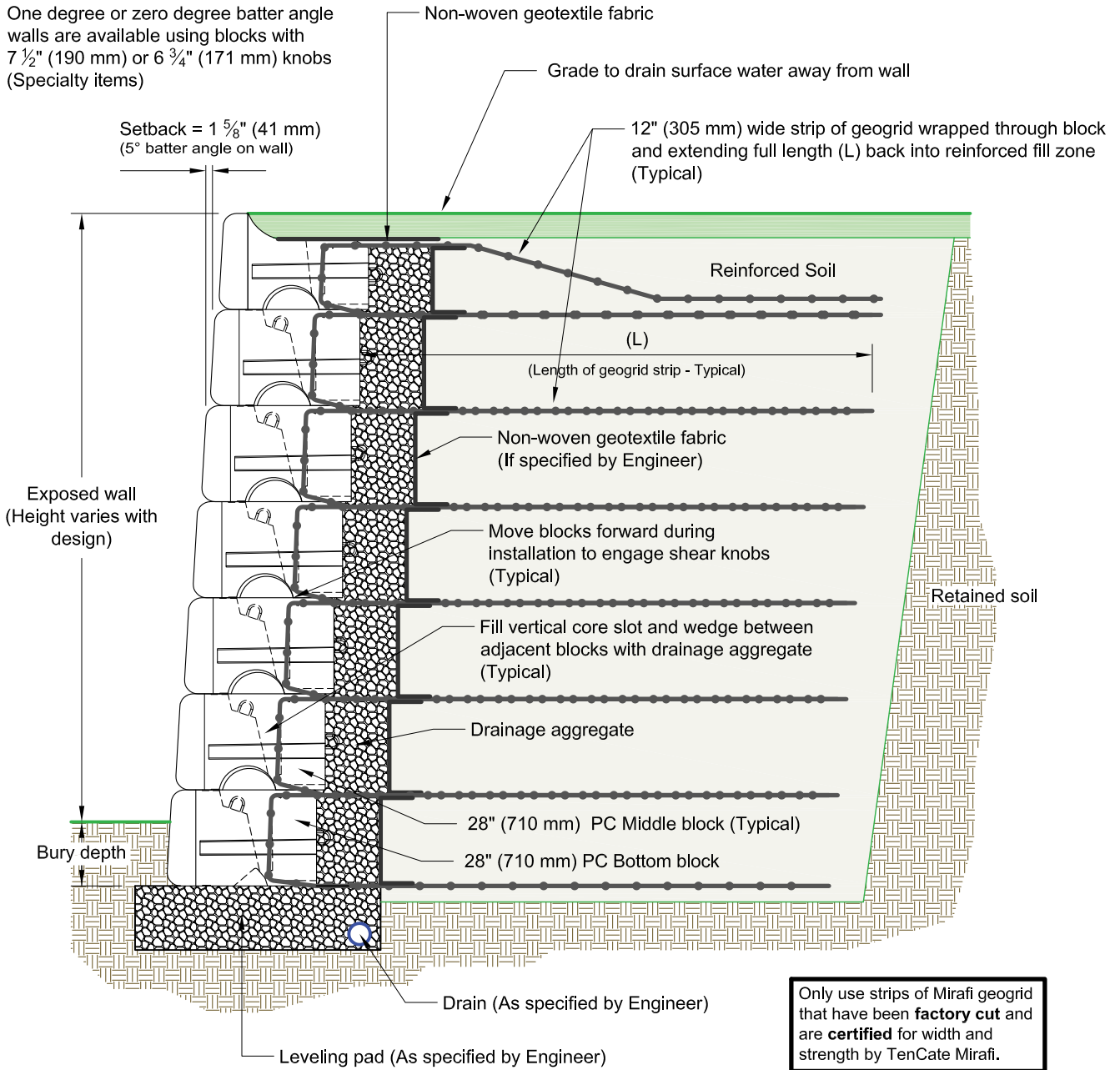

This drawing is for reference only. Determination of the suitability and/or manner of use of any details contained in this document is the sole responsibility of the design engineer of record. Final project designs, including all construction details, shall be prepared by a licensed professional engineer using the actual conditions of the proposed site.

### Conceptual Seawall Detail

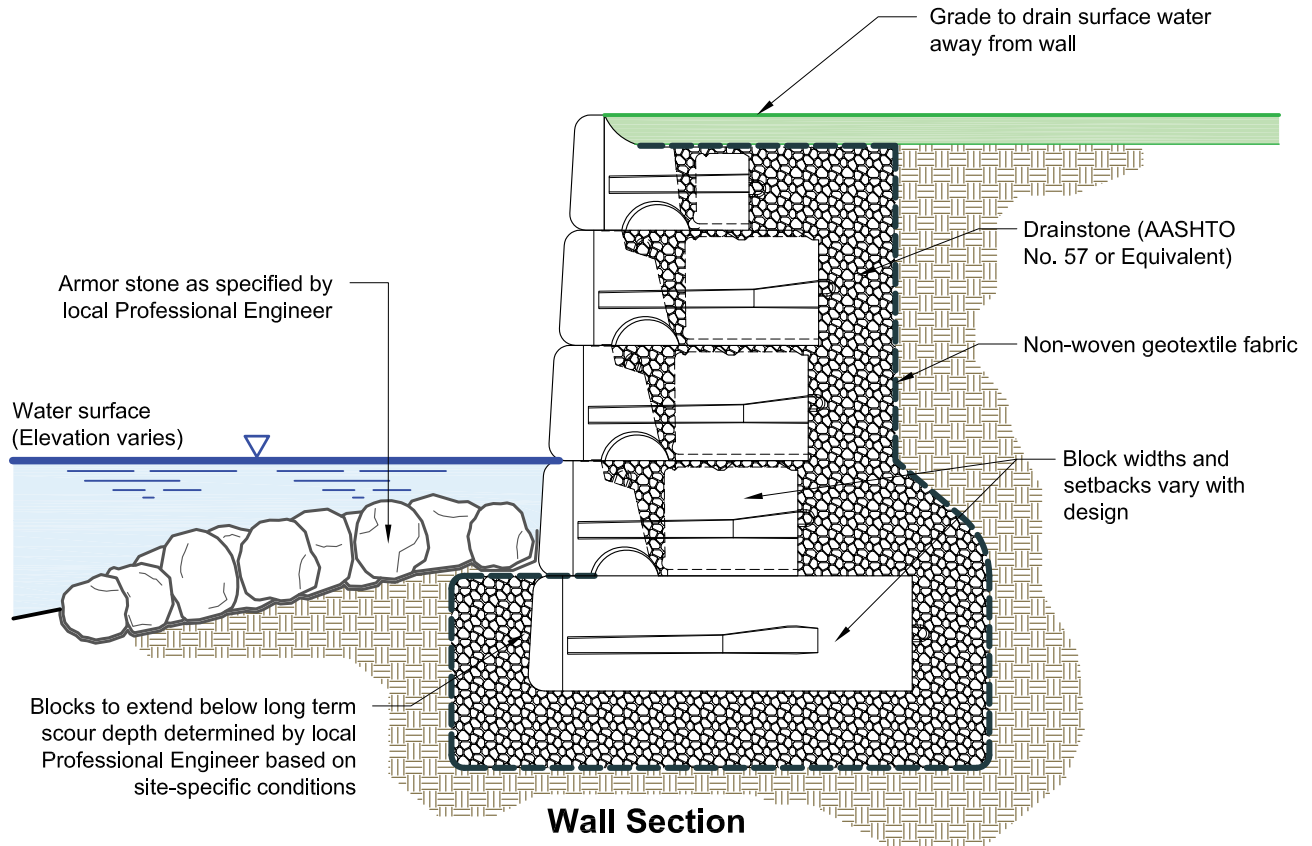

**Notes:**

- Use ASTM No. 57 stone (or as specified by local Professional Engineer) to infill between blocks.
- Preliminary wall height charts do not apply and should not be used for walls in water applications due to the variety of site-specific variables.
- Contact your local Professional Engineer for specific details and final design.
- Walls may require geogrid reinforcement.
- Refer to final engineering plans.

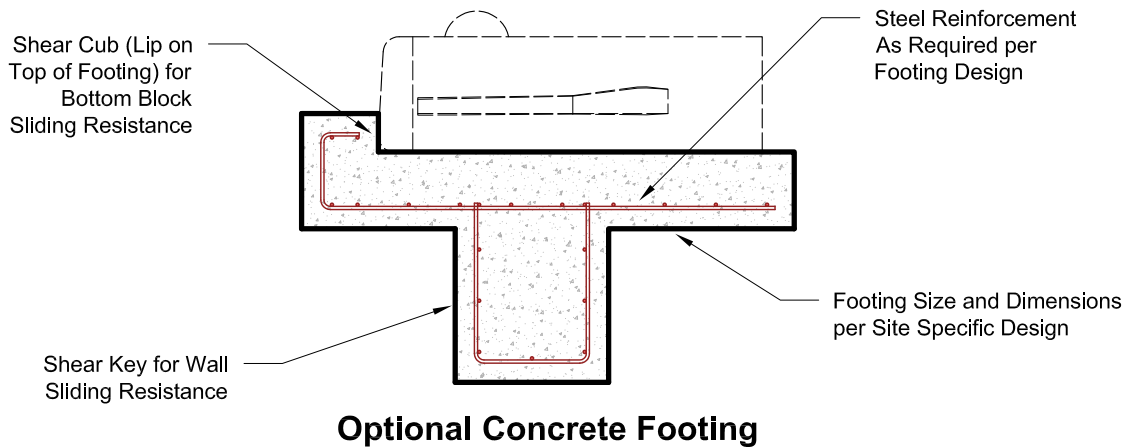

This drawing is for reference only. Determination of the suitability and/or manner of use of any details contained in this document is the sole responsibility of the design engineer of record. Final project designs, including all construction details, shall be prepared by a licensed professional engineer using the actual conditions of the proposed site.

### Wall Drain Weep Hole Options

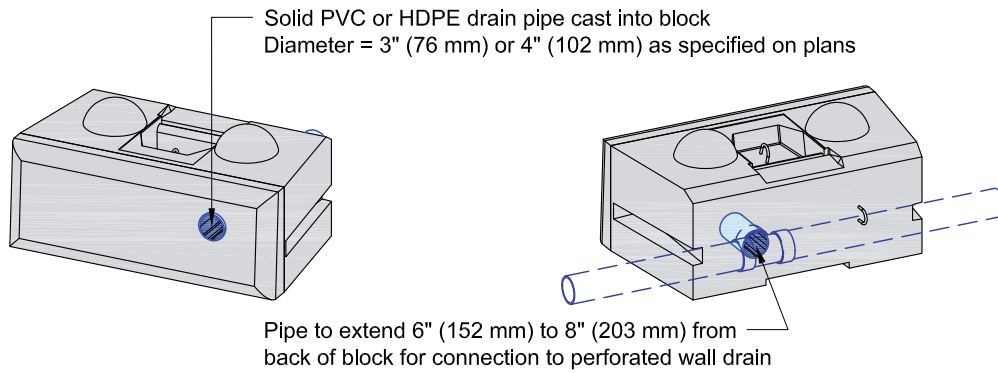

### Custom Pipe Cast into Block

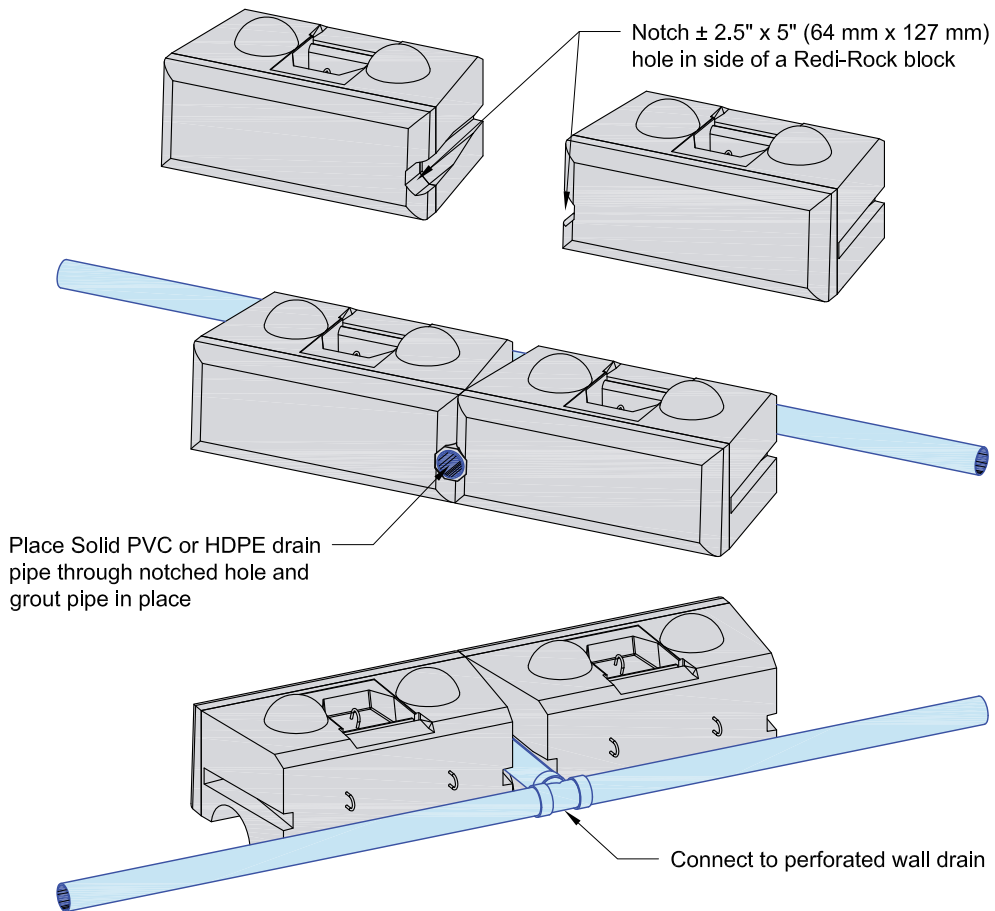

### Field Installed Pipe

This drawing is for reference only. Determination of the suitability and/or manner of use of any details contained in this document is the sole responsibility of the design engineer of record. Final project designs, including all construction details, shall be prepared by a licensed professional engineer using the actual conditions of the proposed site.

### 90° Outside Corner

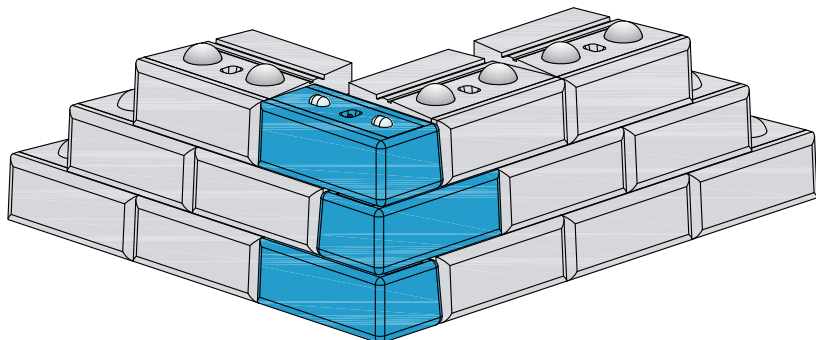

**Isometric View of Corner**

The top row of blocks in this diagram are shown in red. They have been cutout in line with their bottom grooves to show how they fit with the knobs on the bottom row of blocks.

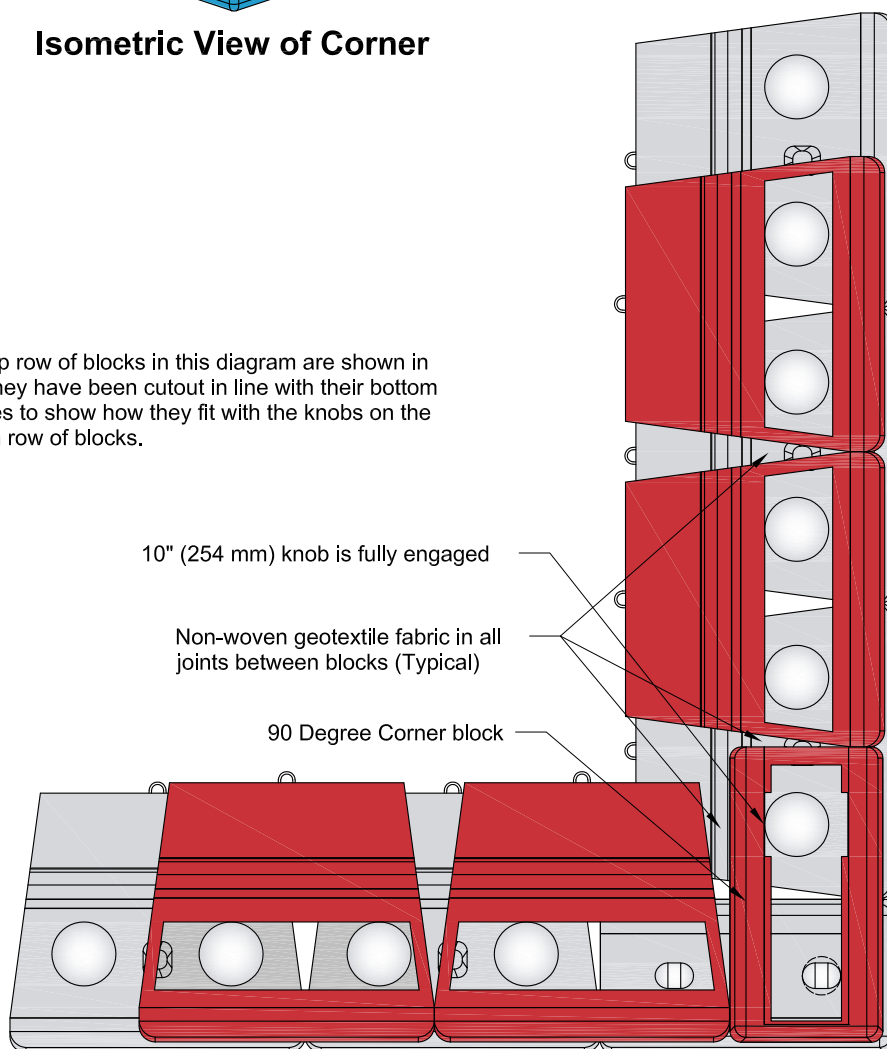

**Top View of Bottom Two Rows**

This drawing is for reference only. Determination of the suitability and/or manner of use of any details contained in this document is the sole responsibility of the design engineer of record. Final project designs, including all construction details, shall be prepared by a licensed professional engineer using the actual conditions of the proposed site.

### Steps Through Wall

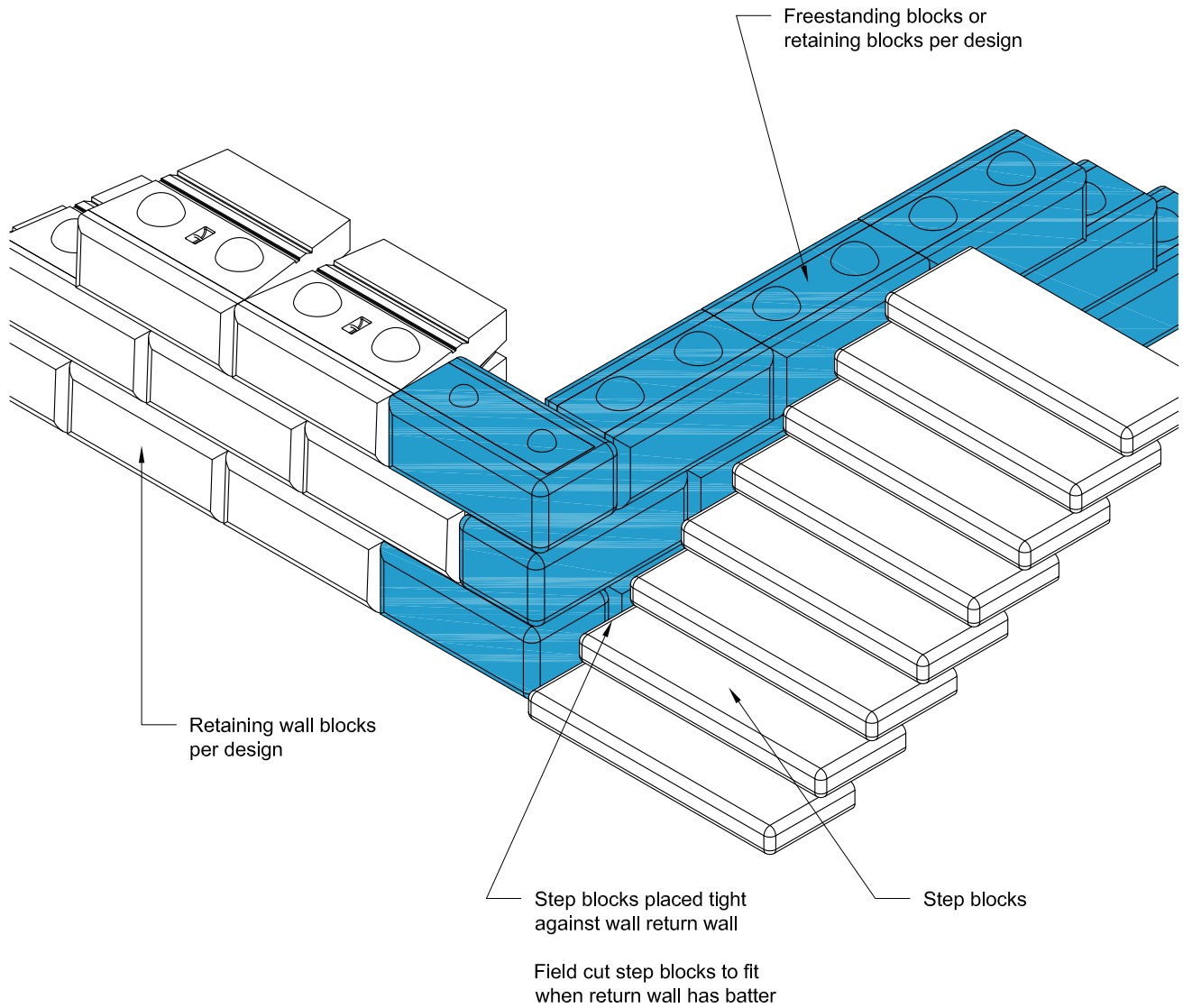

This drawing is for reference only. Determination of the suitability and/or manner of use of any details contained in this document is the sole responsibility of the design engineer of record. Final project designs, including all construction details, shall be prepared by a licensed professional engineer using the actual conditions of the proposed site.

### Flush End to 90° Corner

**Notes:**

- Wall is flush with building.
- Rows 2, 4, 6, and 8 require approximately 1/8" (3 mm) gaps between blocks for length of wall given.
- Solution shown based on a 24" (610 mm) wide corner block.

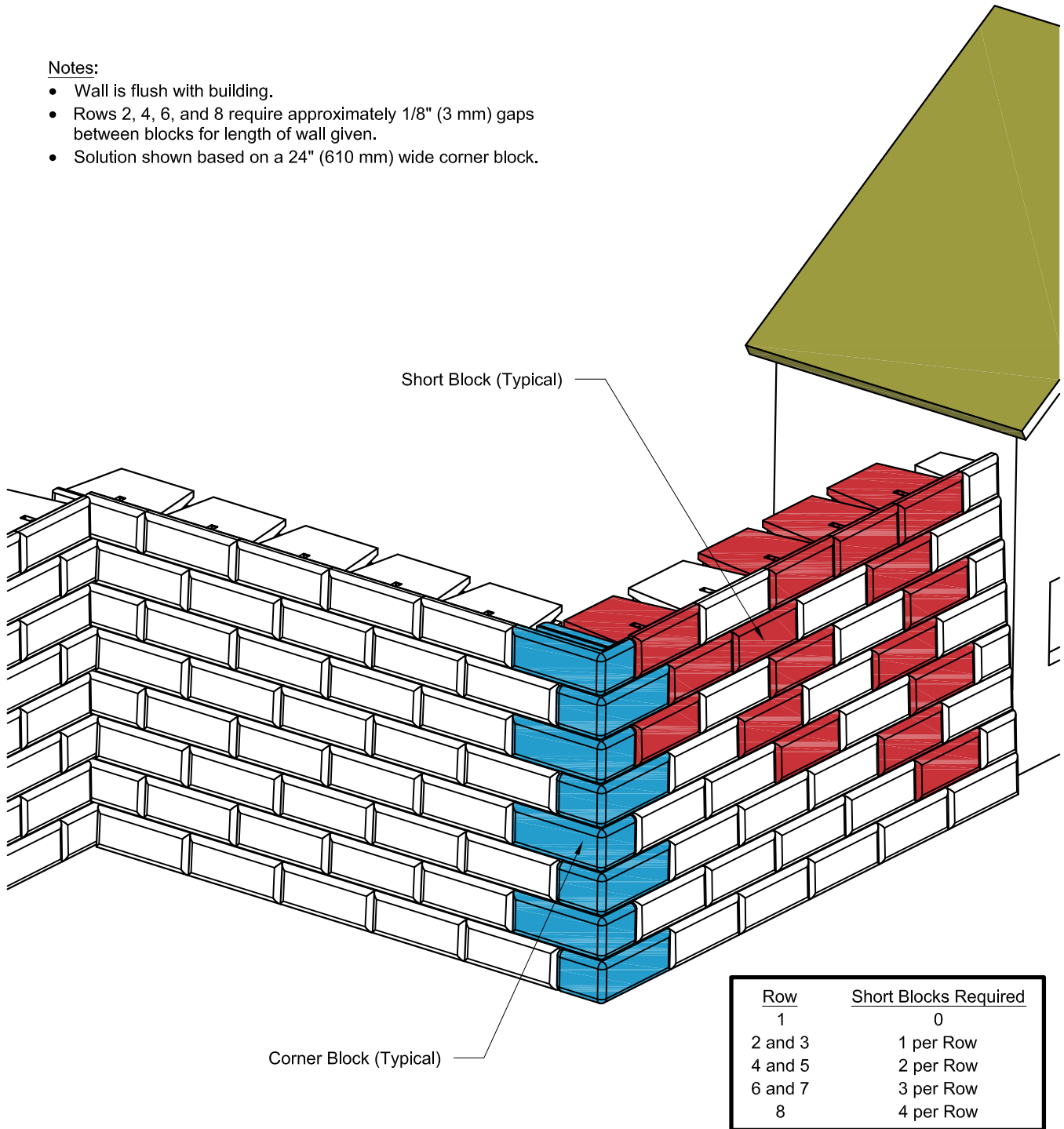

This drawing is for reference only. Determination of the suitability and/or manner of use of any details contained in this document is the sole responsibility of the design engineer of record. Final project designs, including all construction details, shall be prepared by a licensed professional engineer using the actual conditions of the proposed site.

### Double 90° Outside Corner - Short Block Solution

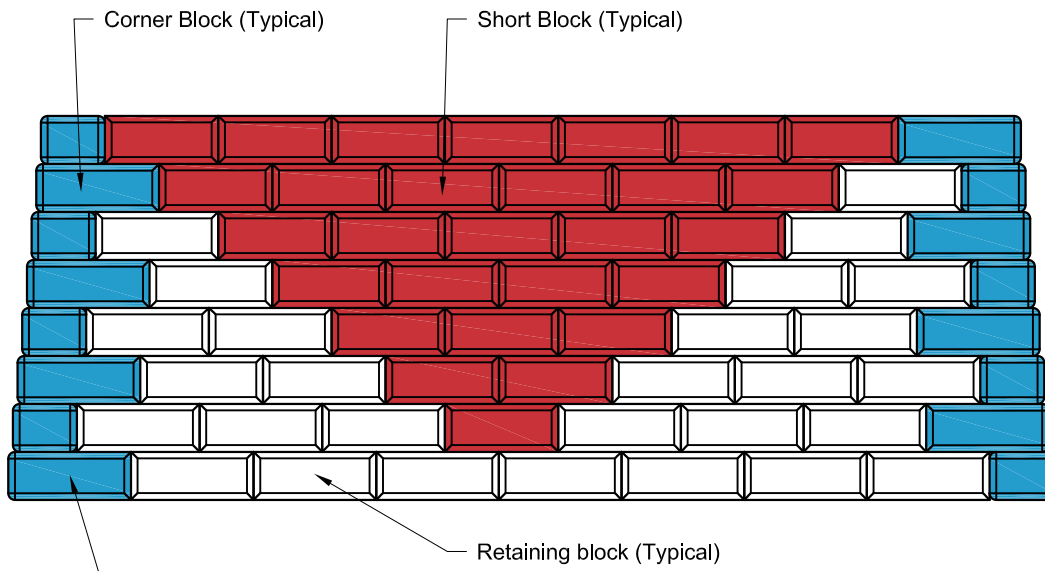

Alternate long and short face of Freestanding Corner block on either end of row for proper spacing (Typical)

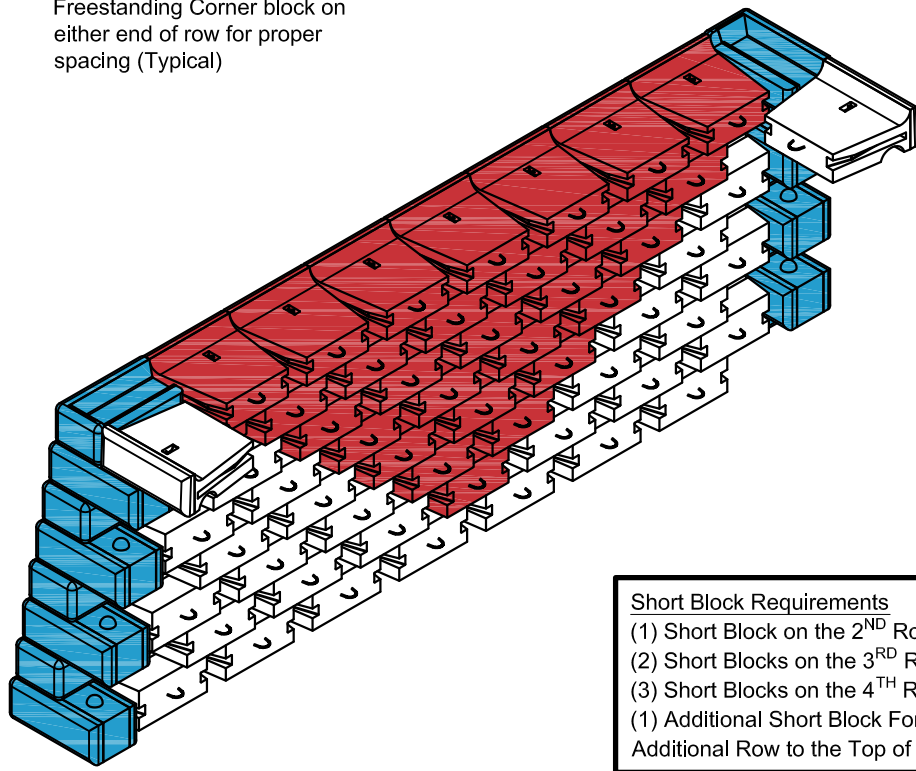

- Short Block Requirements**
- (1) Short Block on the 2<sup>ND</sup> Row
  - (2) Short Blocks on the 3<sup>RD</sup> Row
  - (3) Short Blocks on the 4<sup>TH</sup> Row
  - (1) Additional Short Block For Every Additional Row to the Top of the Wall

This drawing is for reference only. Determination of the suitability and/or manner of use of any details contained in this document is the sole responsibility of the design engineer of record. Final project designs, including all construction details, shall be prepared by a licensed professional engineer using the actual conditions of the proposed site.

### Transitions Into Planters

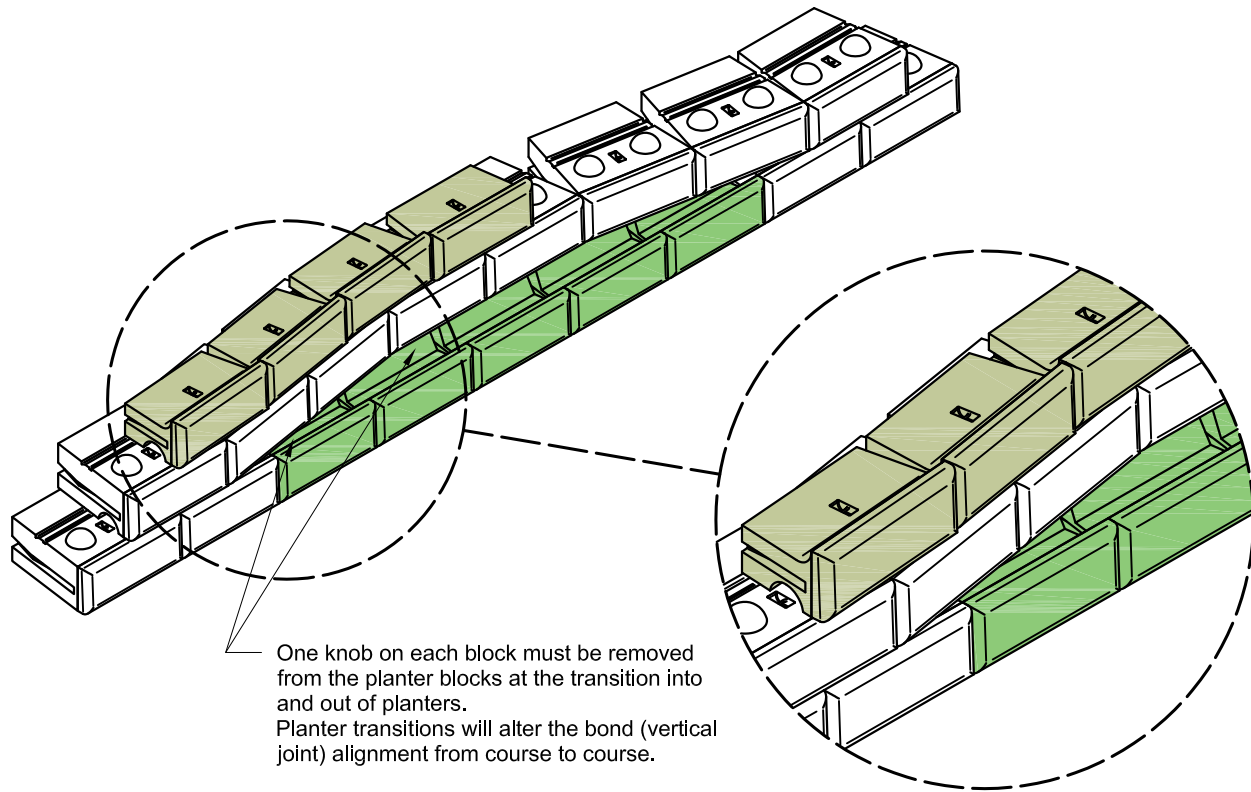

One knob on each block must be removed from the planter blocks at the transition into and out of planters. Planter transitions will alter the bond (vertical joint) alignment from course to course.

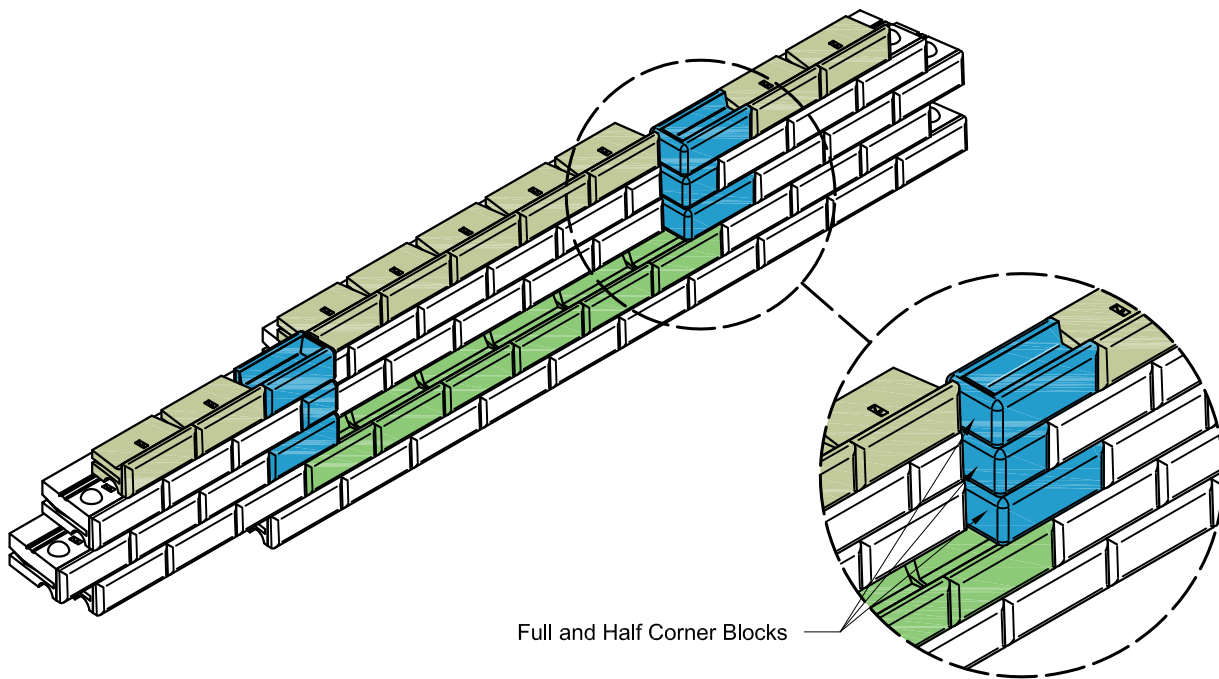

Full and Half Corner Blocks

This drawing is for reference only. Determination of the suitability and/or manner of use of any details contained in this document is the sole responsibility of the design engineer of record. Final project designs, including all construction details, shall be prepared by a licensed professional engineer using the actual conditions of the proposed site.

### Transition From 5° Batter to 9" (230 mm) Setback

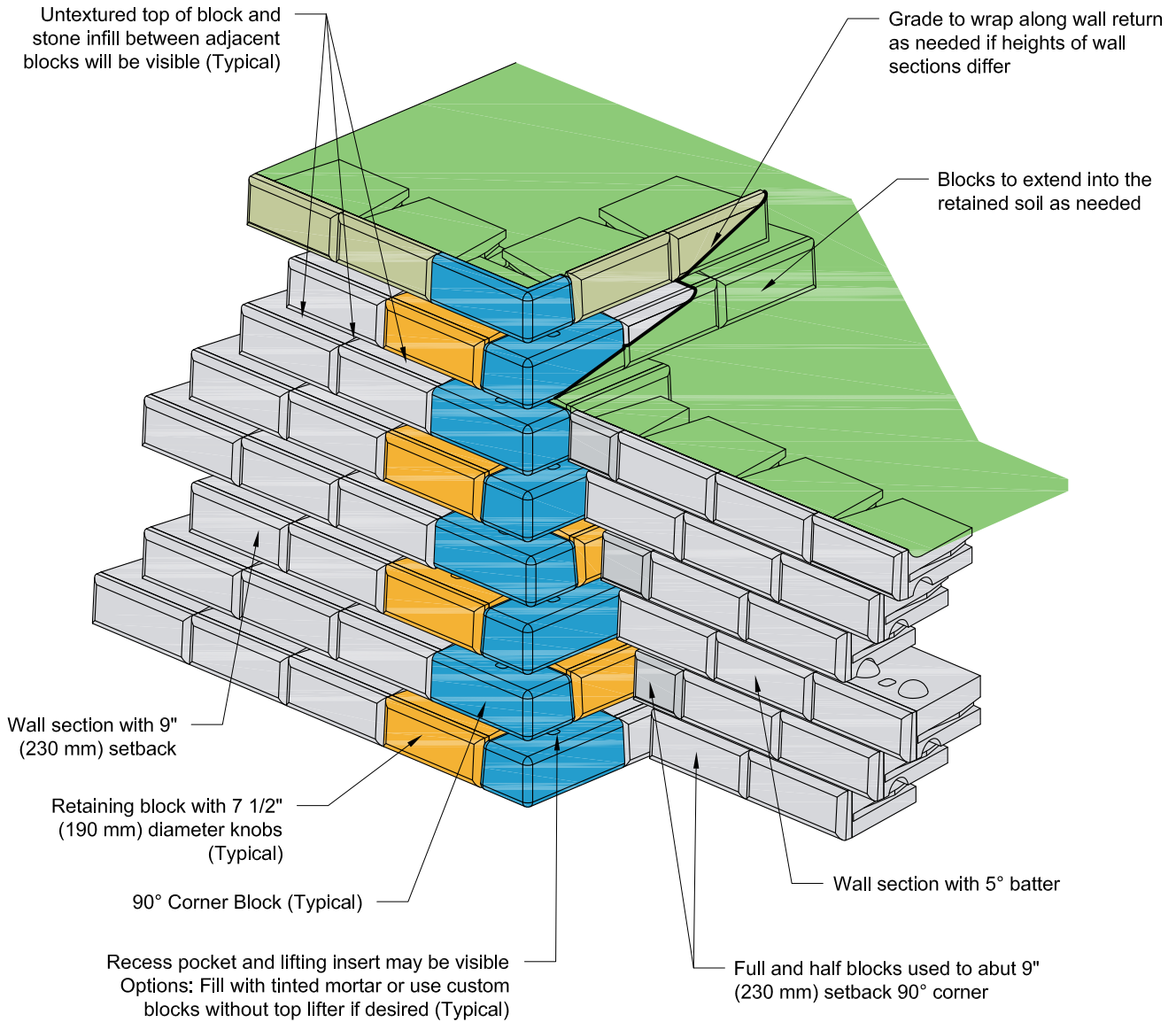

Preferred option is to start construction at transition and work away in both directions.  
If construction cannot start at transition, blocks must be field cut as needed to fit.

This drawing is for reference only. Determination of the suitability and/or manner of use of any details contained in this document is the sole responsibility of the design engineer of record. Final project designs, including all construction details, shall be prepared by a licensed professional engineer using the actual conditions of the proposed site.

### 90° Outside Corner for 9" (230 mm) Setback Walls

Recess pocket and lifting insert may be visible  
Options: Fill with tinted mortar or use custom blocks without top lifter if desired (Typical)

Freestanding Corner Top Block (Typical)

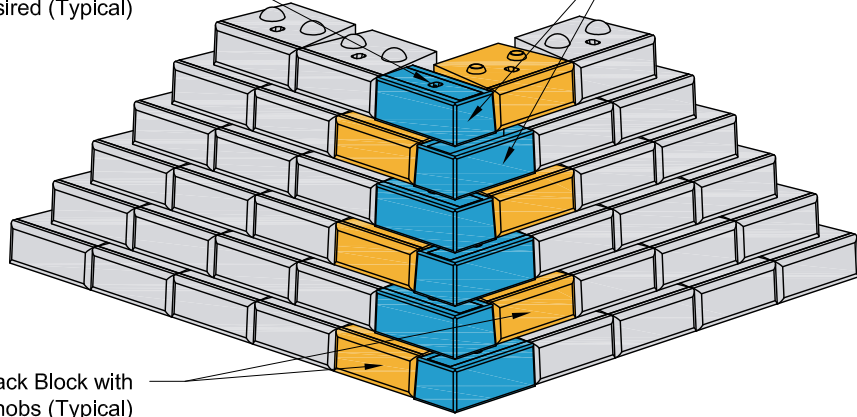

Special 9" (230 mm) Setback Block with 7 1/2" (190 mm) diameter knobs (Typical)

#### Multiple Row Installation

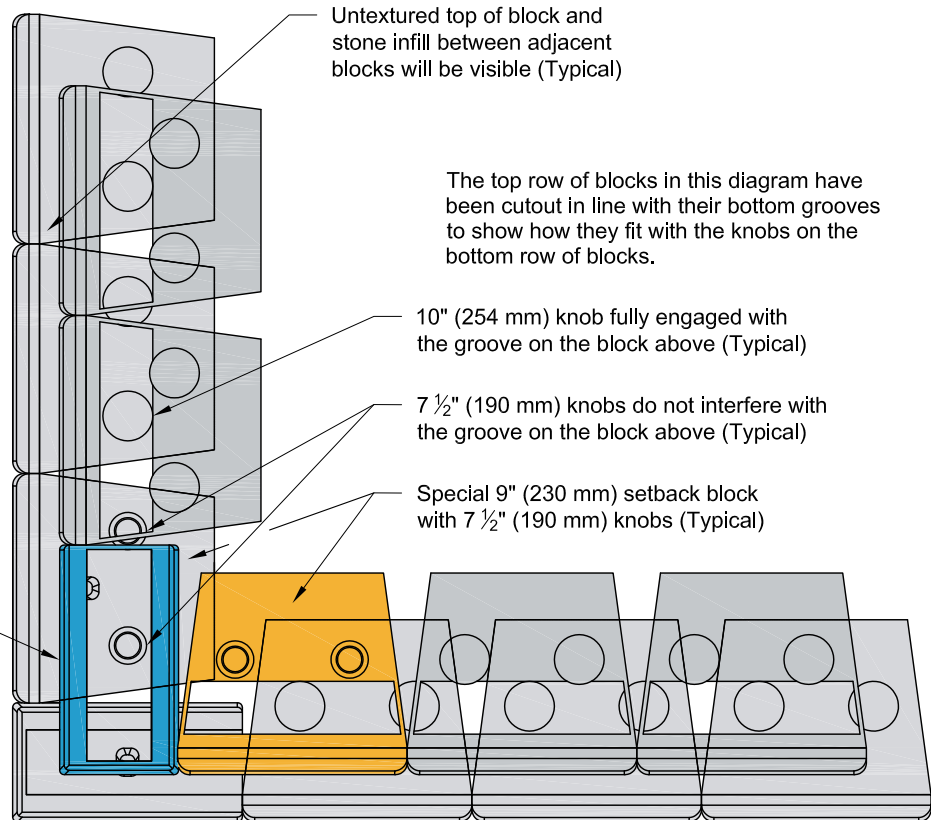

Untextured top of block and stone infill between adjacent blocks will be visible (Typical)

The top row of blocks in this diagram have been cutout in line with their bottom grooves to show how they fit with the knobs on the bottom row of blocks.

10" (254 mm) knob fully engaged with the groove on the block above (Typical)

7 1/2" (190 mm) knobs do not interfere with the groove on the block above (Typical)

Special 9" (230 mm) setback block with 7 1/2" (190 mm) knobs (Typical)

Freestanding Corner Top block (Typical)

#### Top View of Bottom Two Rows

This drawing is for reference only. Determination of the suitability and/or manner of use of any details contained in this document is the sole responsibility of the design engineer of record. Final project designs, including all construction details, shall be prepared by a licensed professional engineer using the actual conditions of the proposed site.

## Double 90° Outside Corner for 9" (230 mm) Setback Walls

### Short Block Requirements

- (1) 9" (230 mm) Setback Short block on the 2<sup>nd</sup> row
- (2) 9" (230 mm) Setback Short block on the 3<sup>rd</sup> row
- (3) 9" (230 mm) Setback Short block on the 4<sup>th</sup> row
- (1) Additional 9" (230 mm) Setback Short block for every additional row to the top of the wall

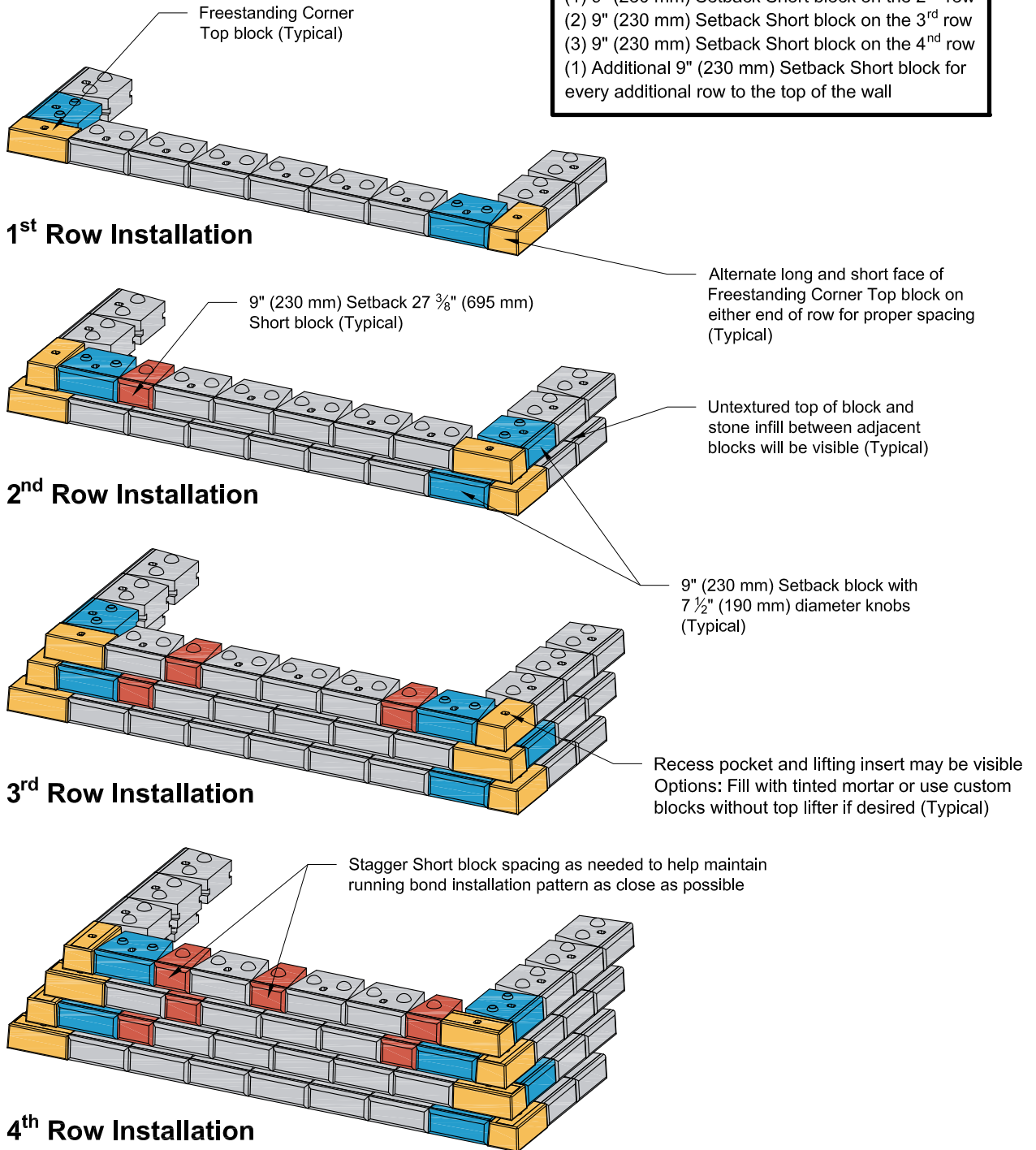

This drawing is for reference only. Determination of the suitability and/or manner of use of any details contained in this document is the sole responsibility of the design engineer of record. Final project designs, including all construction details, shall be prepared by a licensed professional engineer using the actual conditions of the proposed site.

### Stepped 9" (230 mm) Setback Wall with Aligned Base

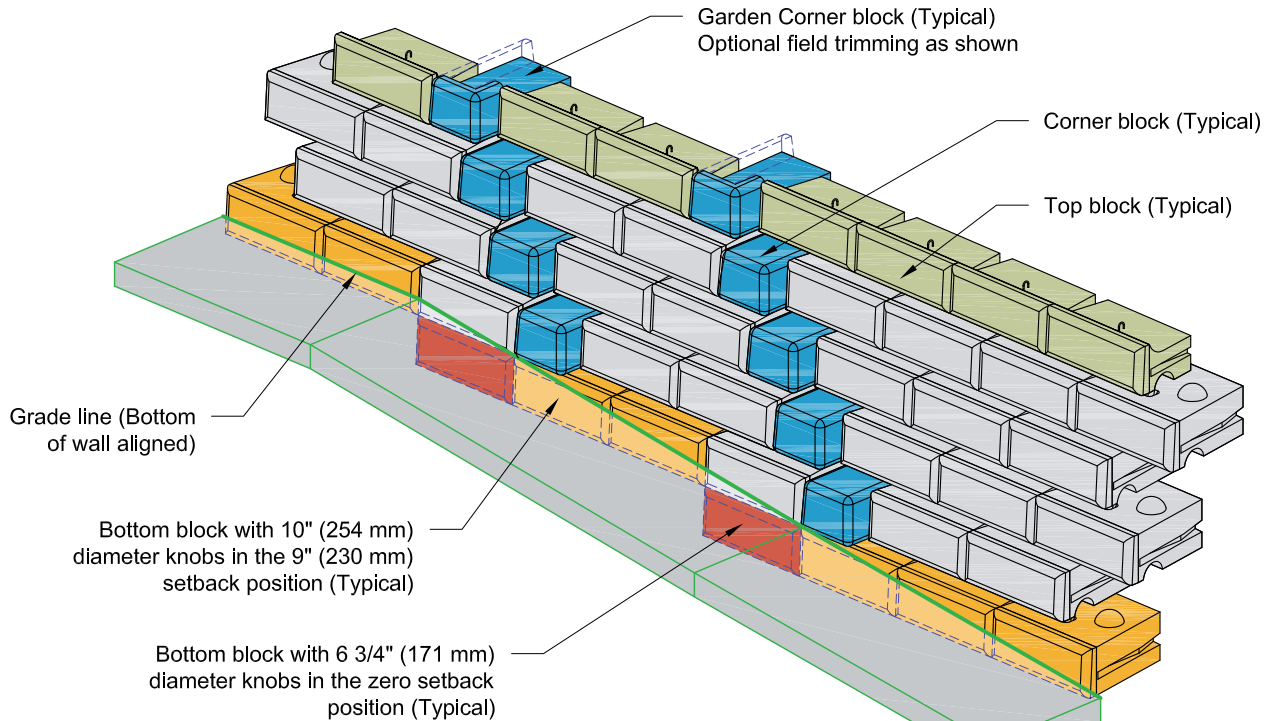

### Parallel Setback

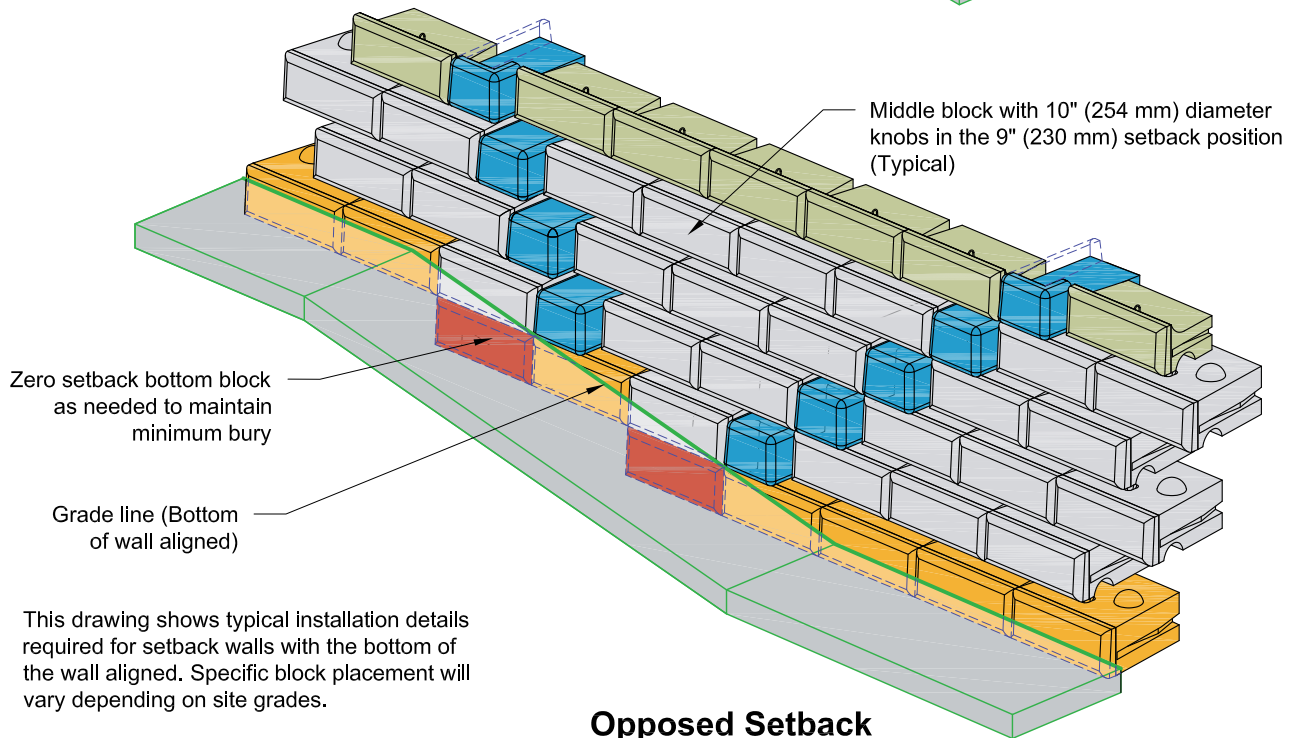

### Opposed Setback

This drawing is for reference only. Determination of the suitability and/or manner of use of any details contained in this document is the sole responsibility of the design engineer of record. Final project designs, including all construction details, shall be prepared by a licensed professional engineer using the actual conditions of the proposed site.

### Stepped 9" (230 mm) Setback Wall with Aligned Top

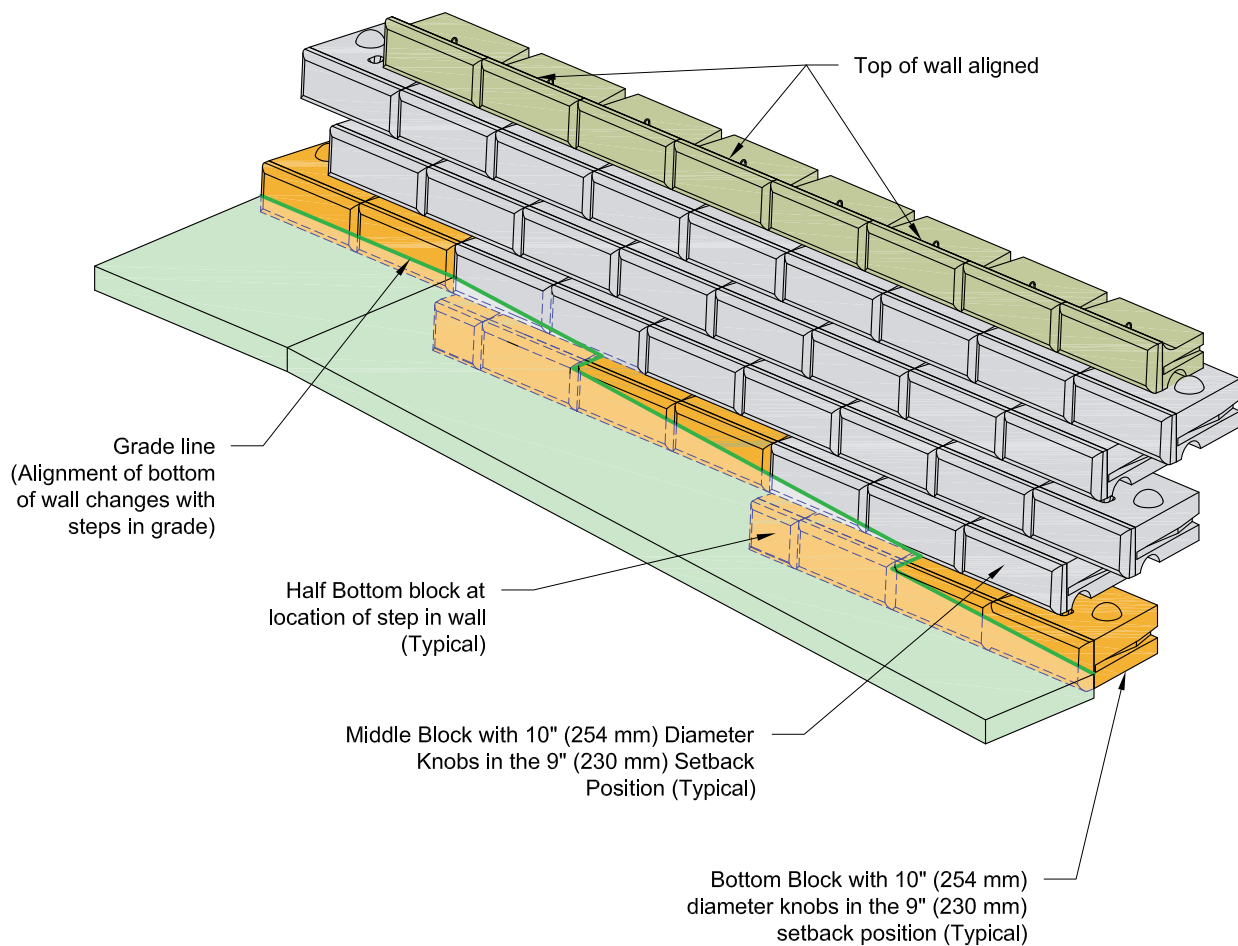

This drawing is for reference only. Determination of the suitability and/or manner of use of any details contained in this document is the sole responsibility of the design engineer of record. Final project designs, including all construction details, shall be prepared by a licensed professional engineer using the actual conditions of the proposed site.

### Freestanding and Cap Block Coping

Secure cap block to freestanding block with polyurethane sealant.  
 Optional shear lugs cast into cap block or rebar ties that can be embedded in site-cast concrete (with garden block) are also available.

Setback = 0" (0 mm) on Freestanding blocks

Setback =  $2 \frac{7}{8}$ " (73 mm) when 10" (254 mm) knob used  
 Setback =  $1 \frac{5}{8}$ " (41 mm) when  $7 \frac{1}{2}$ " (190 mm) knob used

Setback =  $1 \frac{5}{8}$ " (41 mm) when 10" (254 mm) knob used

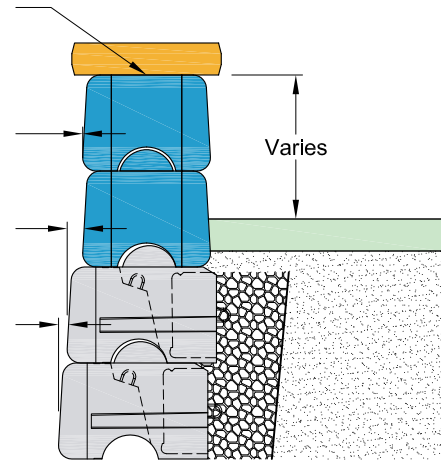

**Section View**

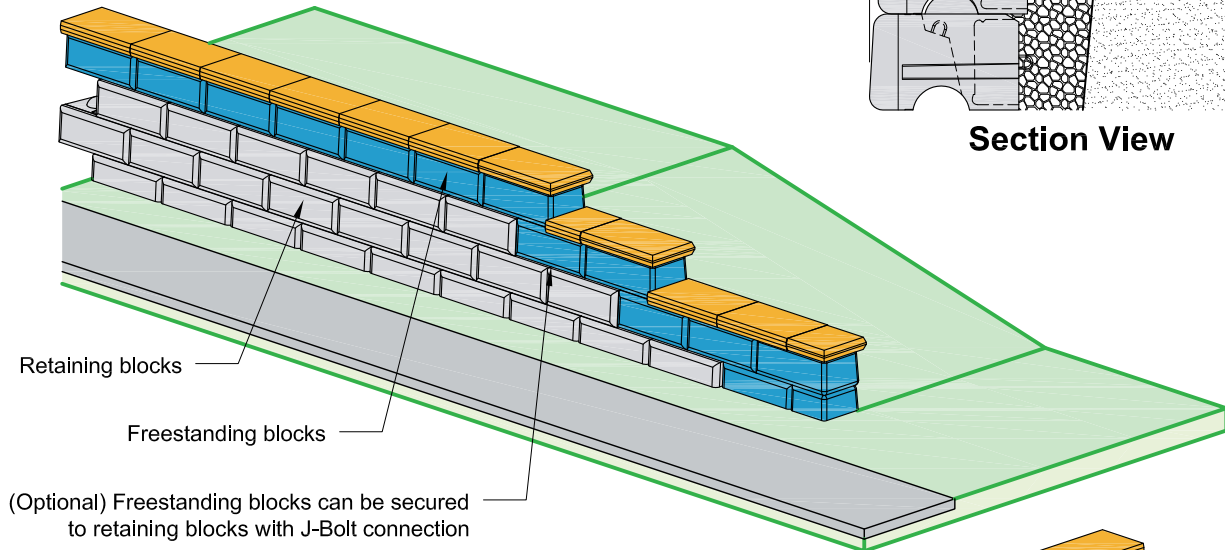

**Front View**

(Optional) Freestanding blocks can be secured to retaining blocks with J-Bolt connection

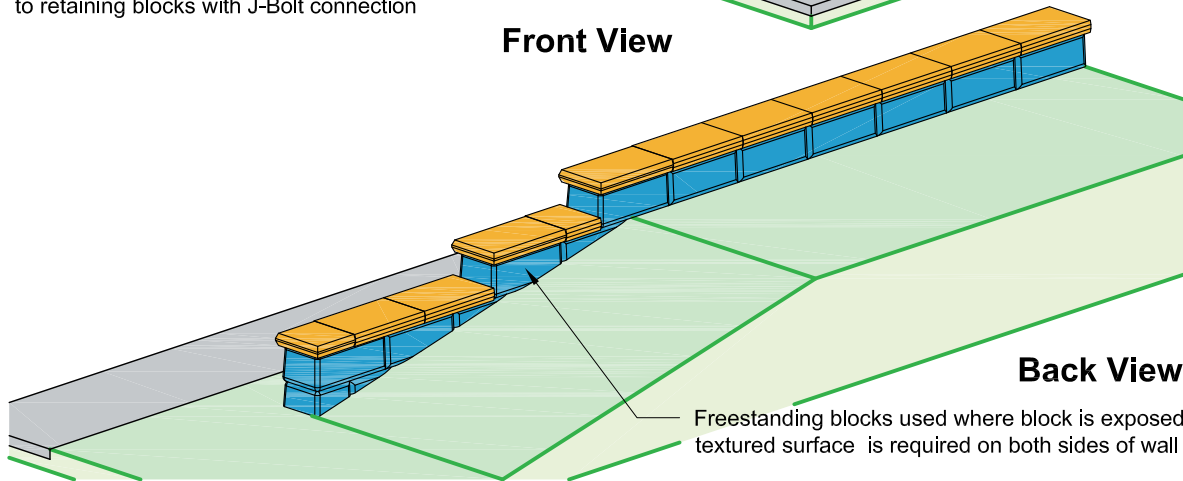

**Back View**

Freestanding blocks used where block is exposed and textured surface is required on both sides of wall

One-component, highly flexible, non-priming, gun grade, high performance elastomeric polyurethane sealant shall have movement of plus or minus 25% per ASTM C719, tensile strength greater than 200 psi (1.4 MPa) per ASTM D412, and adhesion to peel on concrete greater than 20 PLI per ASTM C794. Apply sealant in one and one half-inch (1.5") (38 mm) diameter round "hersey kiss" shaped dollops located in two rows at the top of the Freestanding blocks at 8" (203 mm) on center.

This drawing is for reference only. Determination of the suitability and/or manner of use of any details contained in this document is the sole responsibility of the design engineer of record. Final project designs, including all construction details, shall be prepared by a licensed professional engineer using the actual conditions of the proposed site.

### Drainage Swale Options

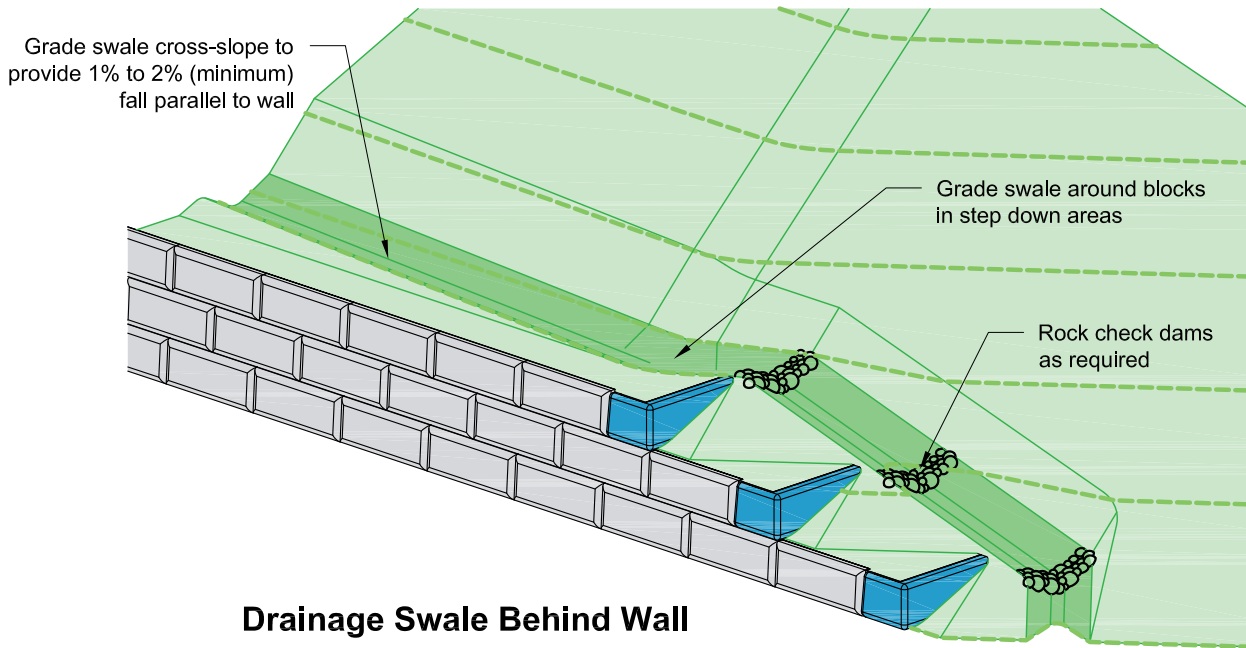
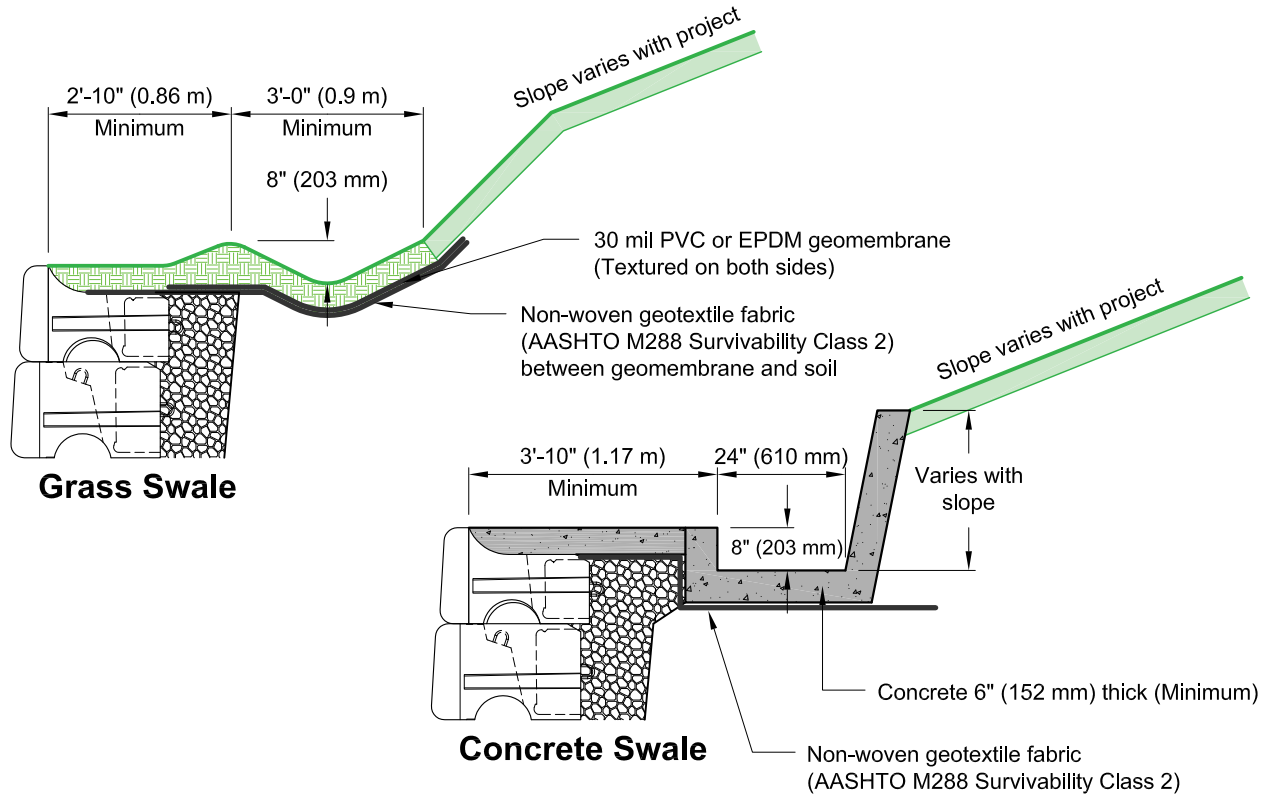

### Drainage Swale Behind Wall

This drawing is for reference only. Determination of the suitability and/or manner of use of any details contained in this document is the sole responsibility of the design engineer of record. Final project designs, including all construction details, shall be prepared by a licensed professional engineer using the actual conditions of the proposed site.

### Top Block Coping Option

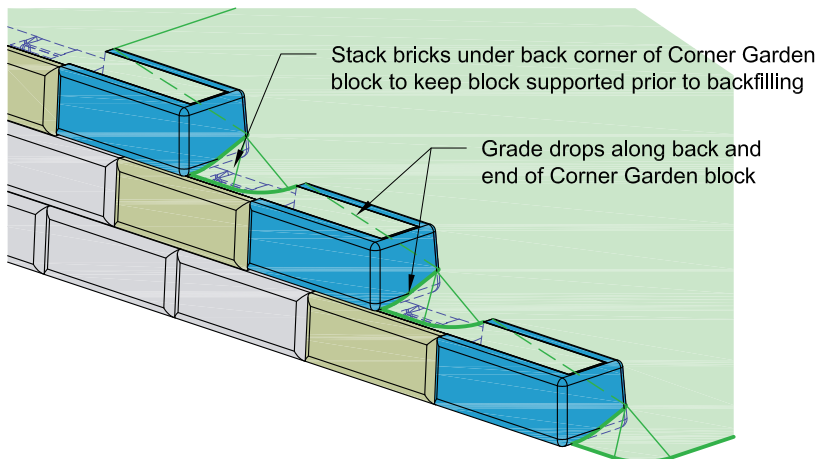

### Alternate Garden Block Placement

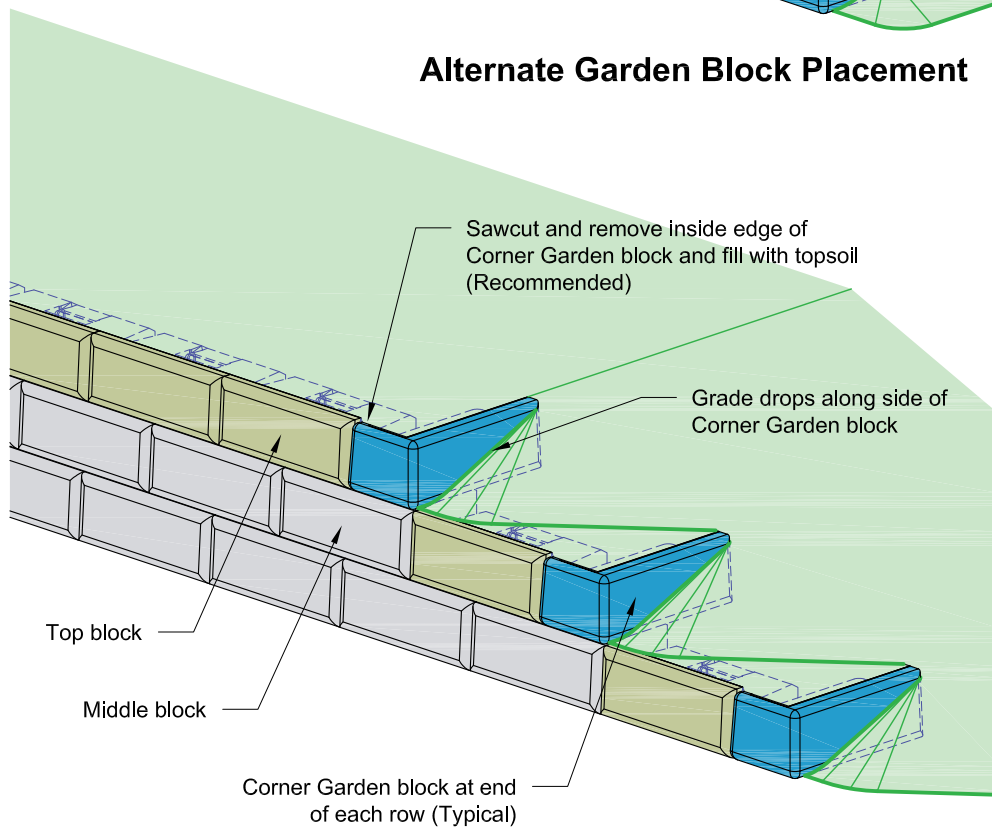

This drawing is for reference only. Determination of the suitability and/or manner of use of any details contained in this document is the sole responsibility of the design engineer of record. Final project designs, including all construction details, shall be prepared by a licensed professional engineer using the actual conditions of the proposed site.

## Grade Change on Top of Wall Using 9" (230 mm) Stepdown Blocks

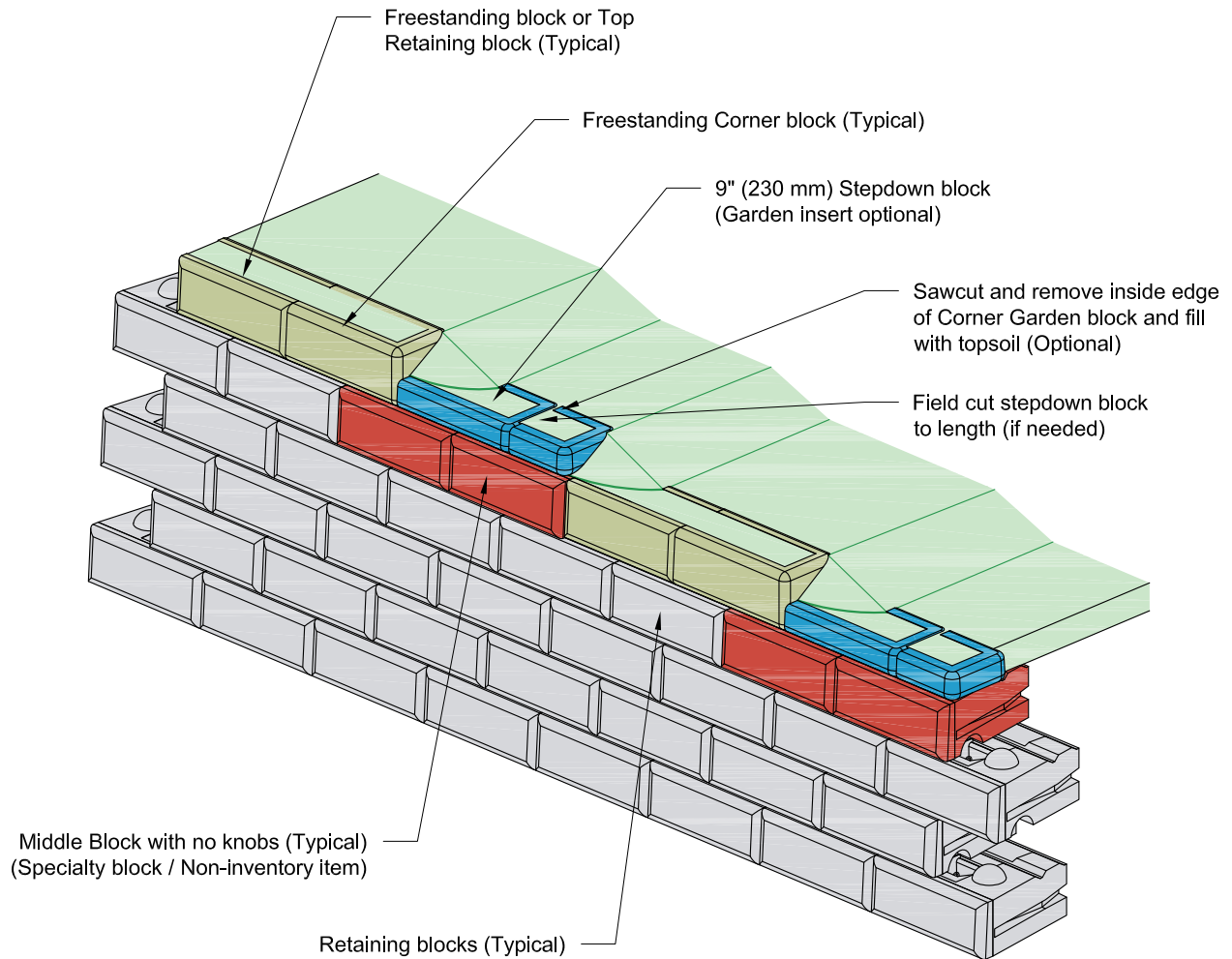

This drawing is for reference only. Determination of the suitability and/or manner of use of any details contained in this document is the sole responsibility of the design engineer of record. Final project designs, including all construction details, shall be prepared by a licensed professional engineer using the actual conditions of the proposed site.

### Geogrid Layout for Convex Curves and Radial Corners

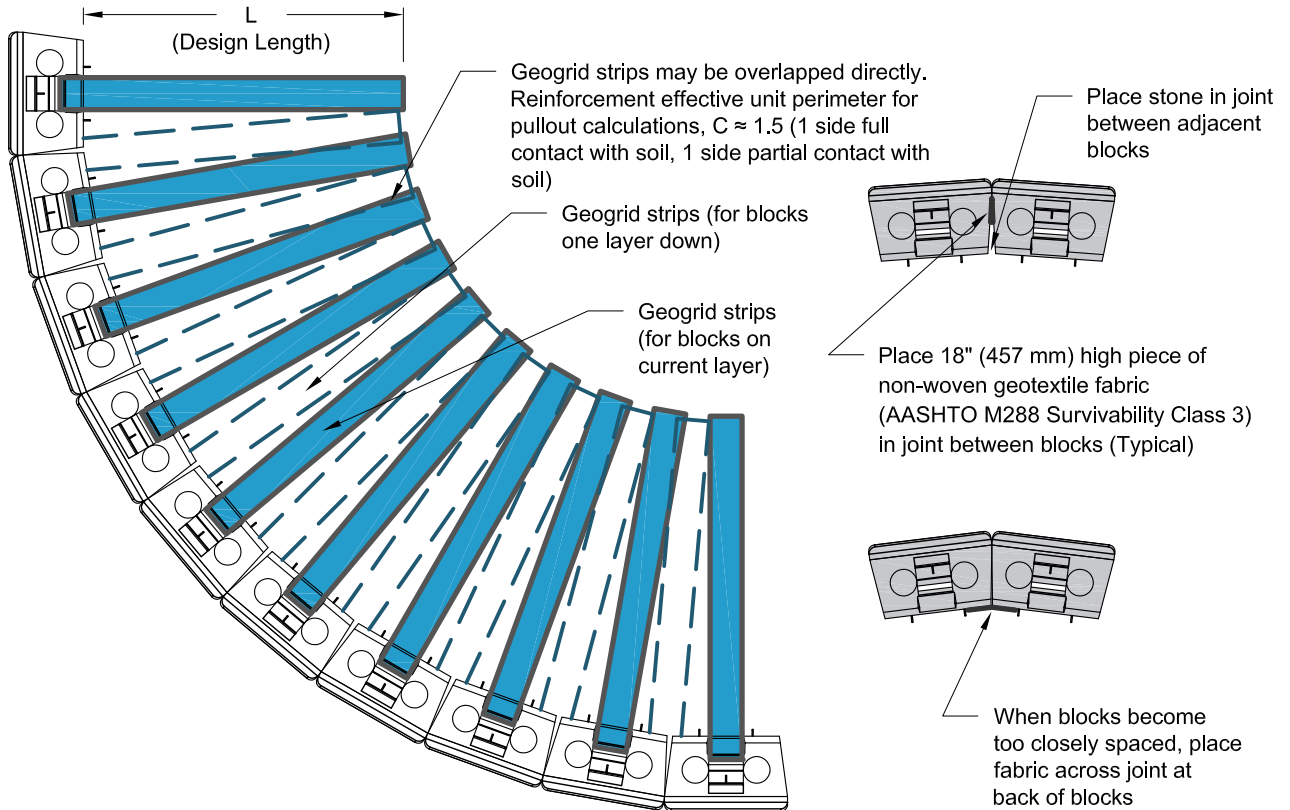

### Minimum radius for bottom row

Number of courses	Height of wall	Radius from face of block	Distance between blocks*
1	1'-6" (0.46 m)	14'-6" (4.42 m)	0.13" (3 mm)
2	3'-0" (0.91 m)	14'-8" (4.47 m)	0.21" (5 mm)
3	4'-6" (1.37 m)	14'-10" (4.52 m)	0.28" (7 mm)
4	6'-0" (1.83 m)	15'-0" (4.57 m)	0.36" (9 mm)
5	7'-6" (2.29 m)	15'-2" (4.62 m)	0.43" (11 mm)
6	9'-0" (2.74 m)	15'-4" (4.67 m)	0.50" (13 mm)
7	10'-6" (3.20 m)	15'-6" (4.72 m)	0.57" (15 mm)
8	12'-0" (3.66 m)	15'-8" (4.78 m)	0.63" (16 mm)
9	13'-6" (4.11 m)	15'-10" (4.83 m)	0.70" (18 mm)
10	15'-0" (4.57 m)	16'-0" (4.88 m)	0.76" (19 mm)
11	16'-6" (5.03 m)	16'-2" (4.93 m)	0.83" (21 mm)
12	18'-0" (5.49 m)	16'-4" (4.98 m)	0.88" (22 mm)
13	19'-6" (5.94 m)	16'-6" (5.03 m)	0.95" (24 mm)
14	21'-0" (6.40 m)	16'-8" (5.08 m)	1.01" (26 mm)

\* Distance between blocks is measured at the back of 28" (710 mm) blocks and 24" (610 mm) behind the form parting line (back edge of face texture) for 41" (1030 mm) blocks. This distance is intended to be a guide only. Minimum radius is controlling.

14'-6" (4.42 m) is the minimum radius for Redi-Rock blocks. It occurs when all the blocks are placed tight together. A larger radius is required on the bottom row of a Redi-Rock wall to account for the batter between courses of blocks and still provide enough space to construct the top row of blocks.

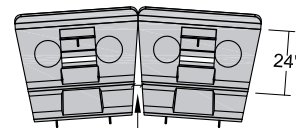

Top View

\* Distance between blocks

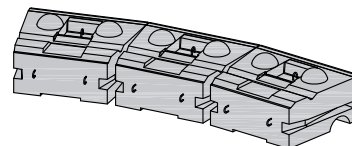

Back View

This drawing is for reference only. Determination of the suitability and/or manner of use of any details contained in this document is the sole responsibility of the design engineer of record. Final project designs, including all construction details, shall be prepared by a licensed professional engineer using the actual conditions of the proposed site.

### Geogrid Layout for Concave Curves and Radial Corners

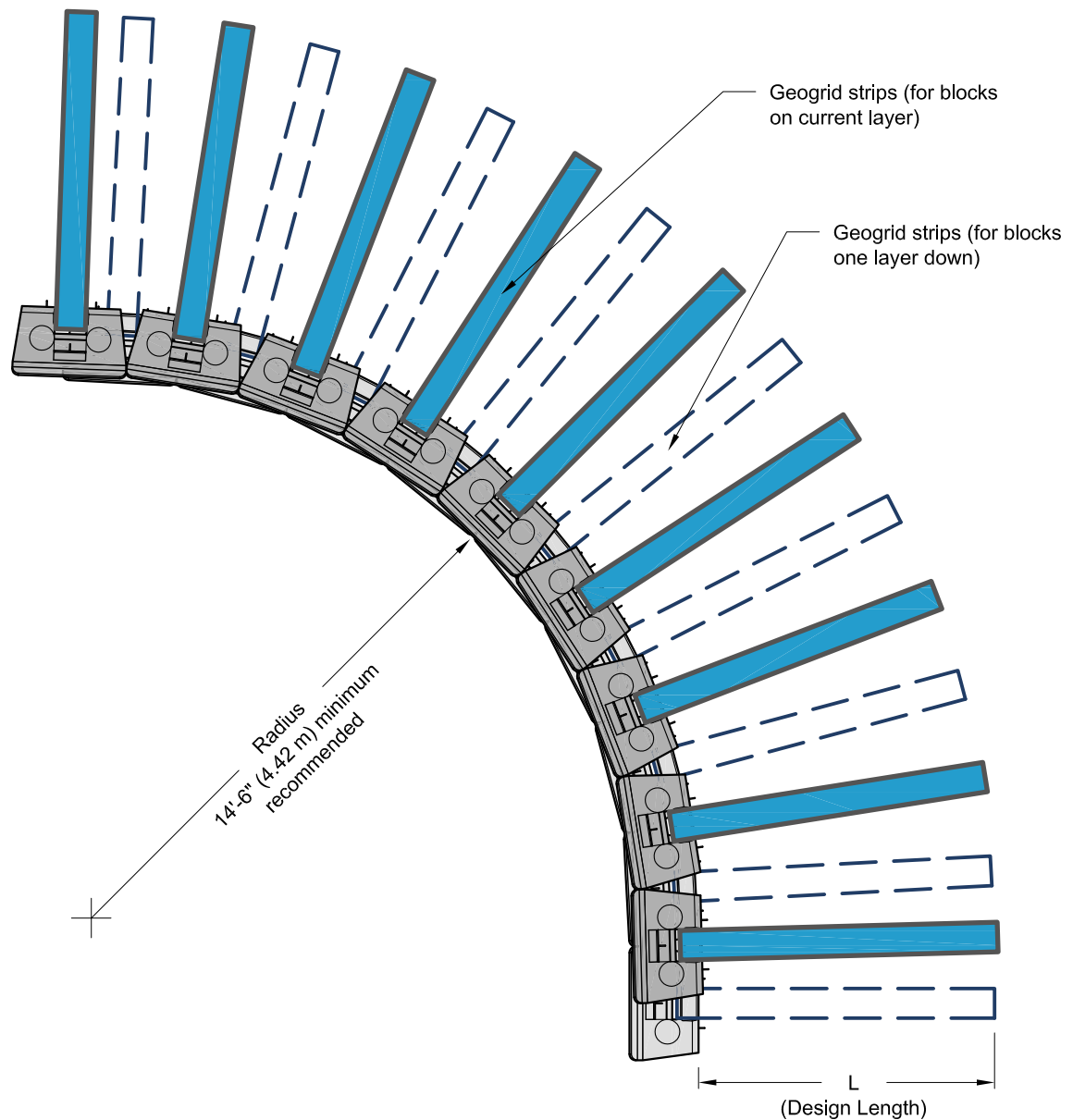

This drawing is for reference only. Determination of the suitability and/or manner of use of any details contained in this document is the sole responsibility of the design engineer of record. Final project designs, including all construction details, shall be prepared by a licensed professional engineer using the actual conditions of the proposed site.

### Geogrid Layout for 90° Inside Corner

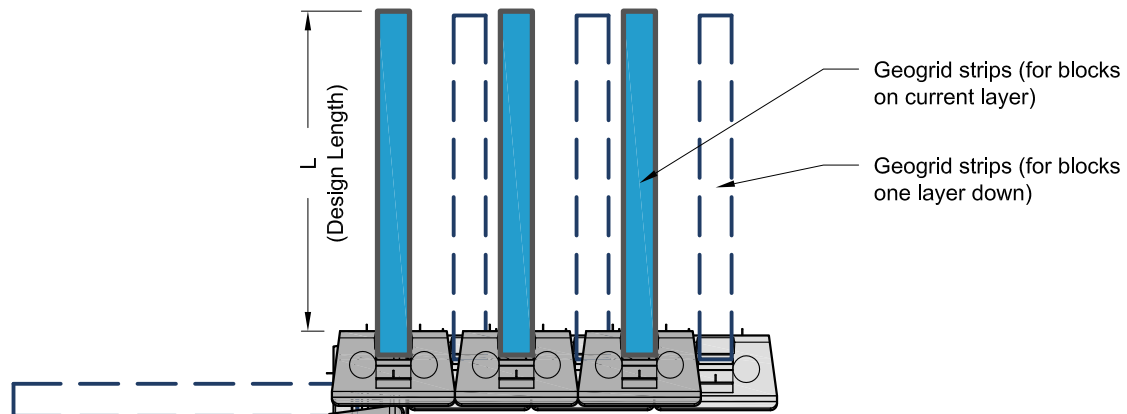

**Top View**

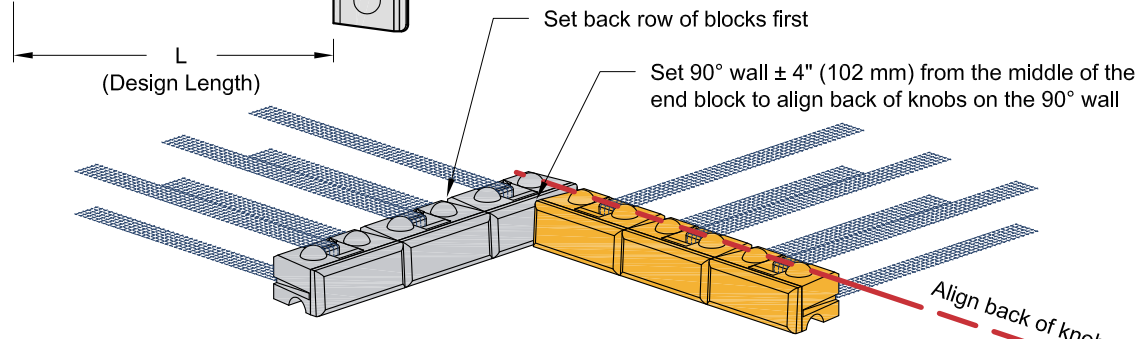

**Block placement - First row**

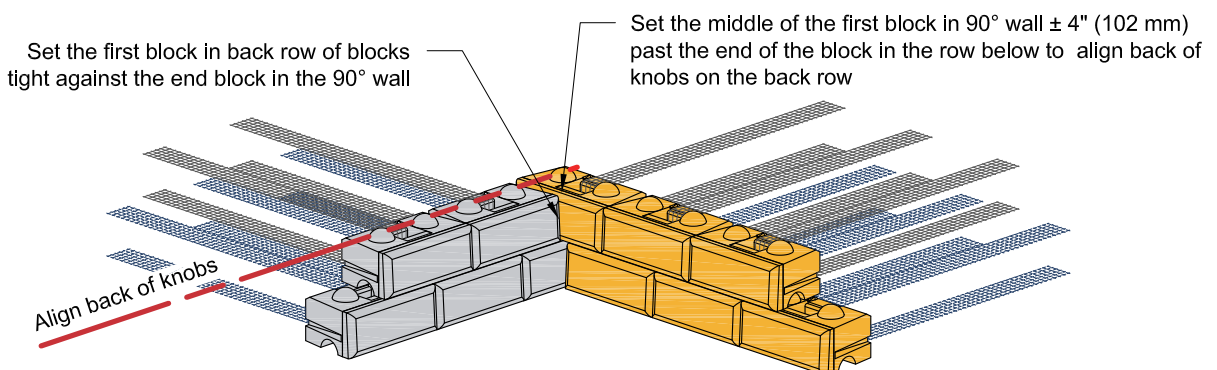

**Block placement - Second row**

This drawing is for reference only. Determination of the suitability and/or manner of use of any details contained in this document is the sole responsibility of the design engineer of record. Final project designs, including all construction details, shall be prepared by a licensed professional engineer using the actual conditions of the proposed site.

### Geogrid Layout for 90° Outside Corner

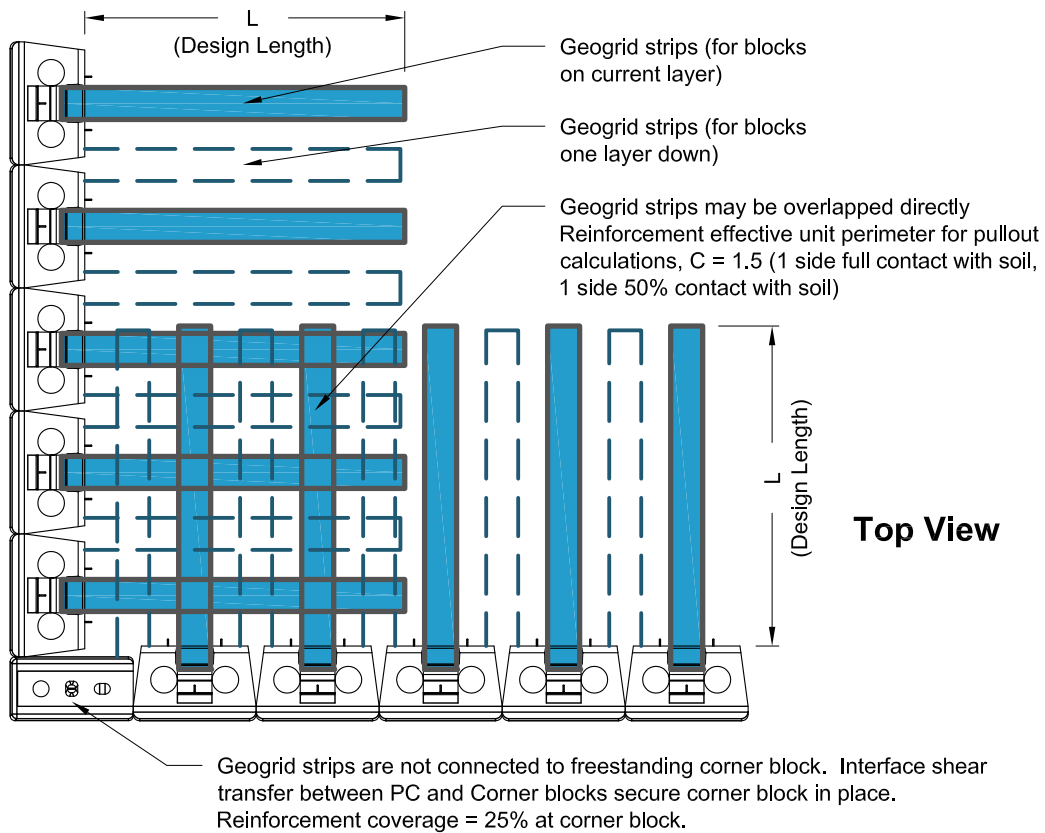

### Block Layout for 90° Outside Corner

The top row of blocks are shown in red. They have been cutout in line with their bottom grooves to show how they fit with the knobs on the bottom row of block. The geogrid strips are not shown for clarity.

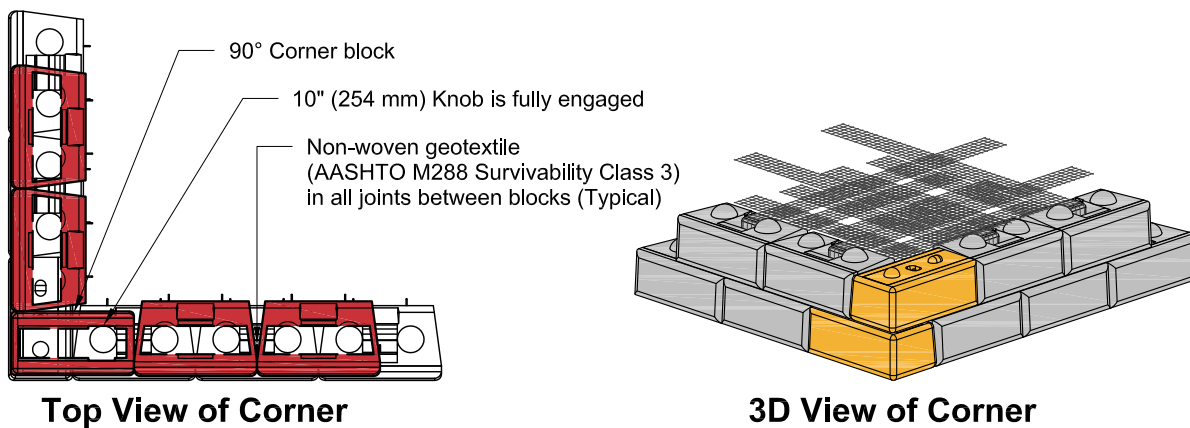

This drawing is for reference only. Determination of the suitability and/or manner of use of any details contained in this document is the sole responsibility of the design engineer of record. Final project designs, including all construction details, shall be prepared by a licensed professional engineer using the actual conditions of the proposed site.

### Internal Drainage Options

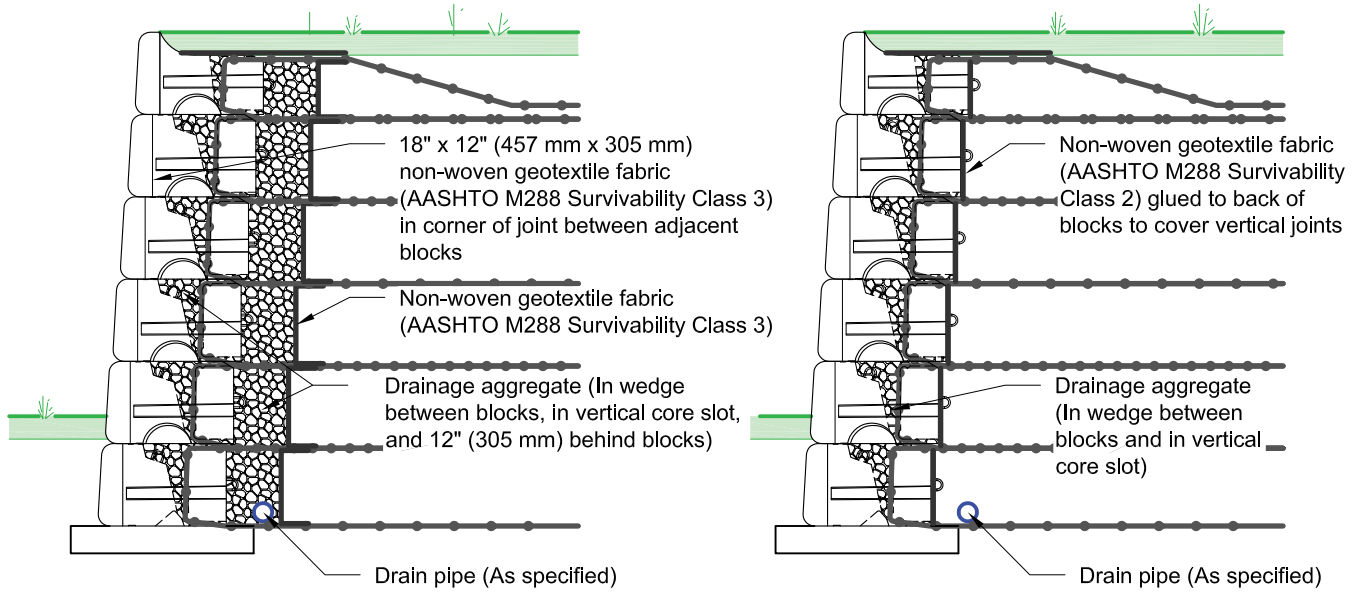

Typical Section - Option 1

Typical Section - Option 2

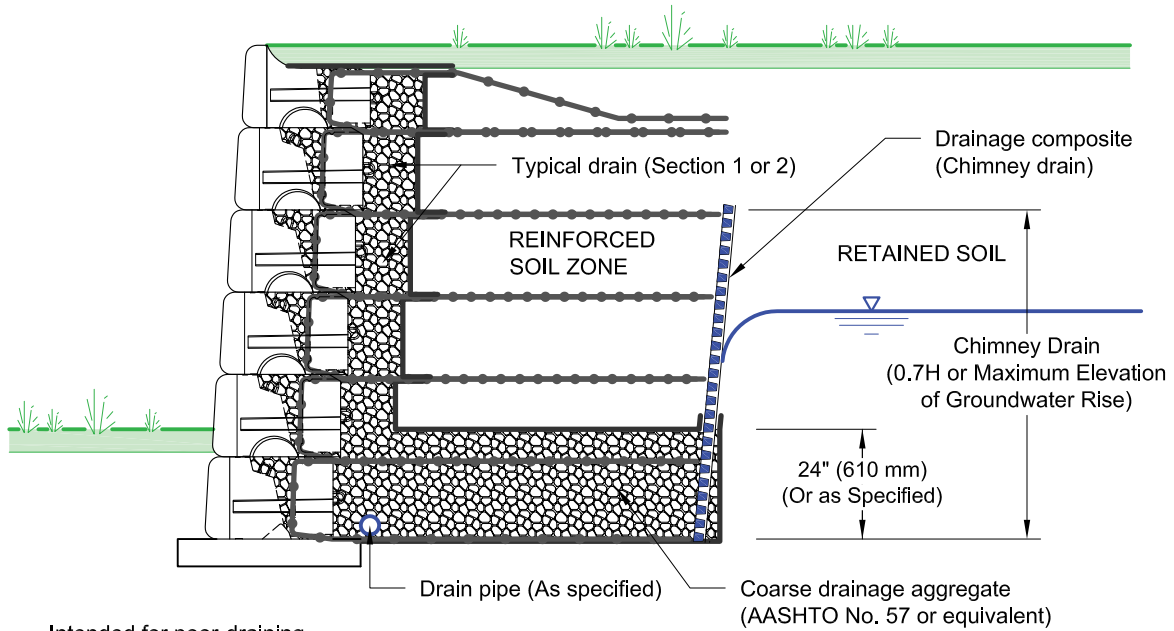

Intended for poor-draining retained soils and/or areas with potential groundwater impact

### Blanket and Chimney Drain Section

This drawing is for reference only. Determination of the suitability and/or manner of use of any details contained in this document is the sole responsibility of the design engineer of record. Final project designs, including all construction details, shall be prepared by a licensed professional engineer using the actual conditions of the proposed site.



### Light Pole Base or Concrete Pile in Reinforced Soil Zone

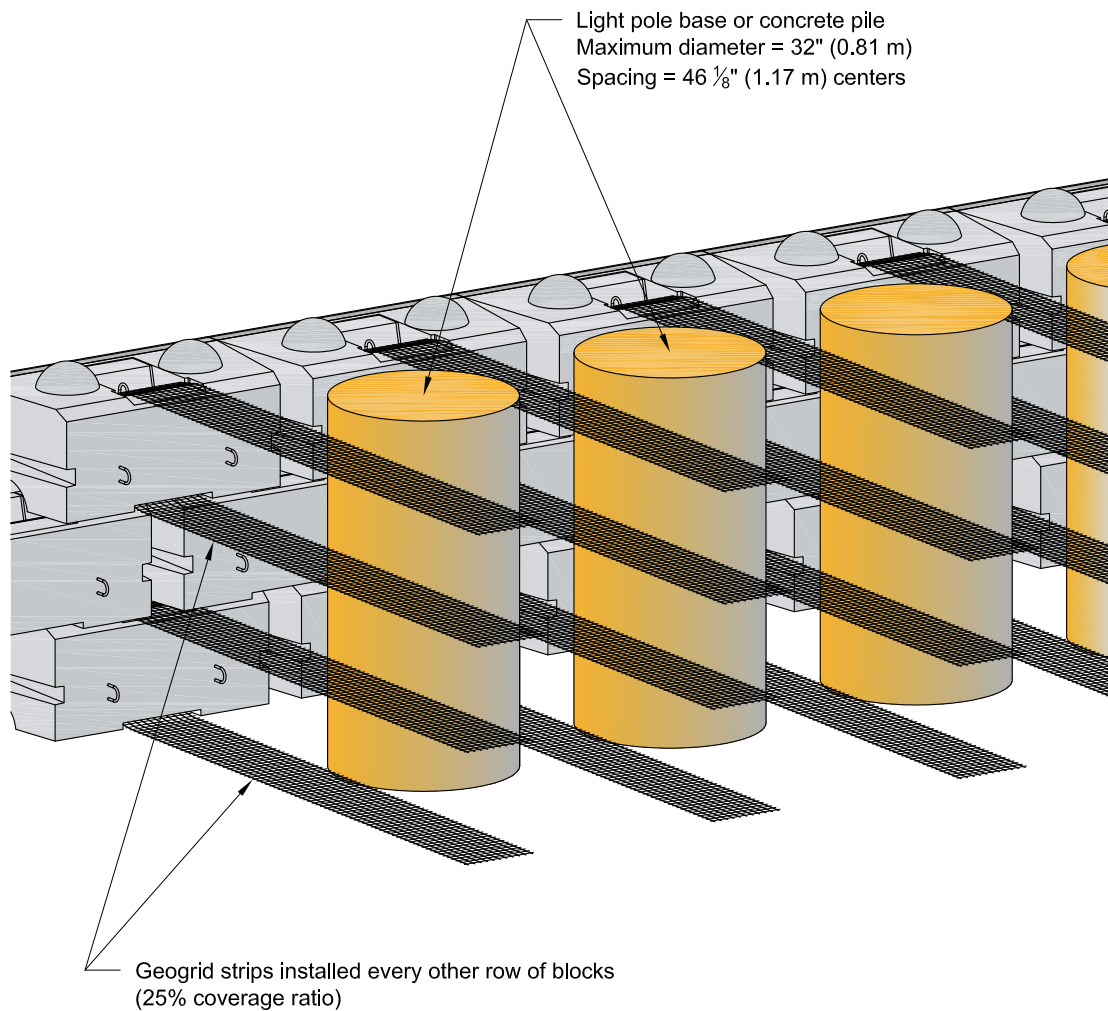

### 3D View from Back

This drawing is for reference only. Determination of the suitability and/or manner of use of any details contained in this document is the sole responsibility of the design engineer of record. Final project designs, including all construction details, shall be prepared by a licensed professional engineer using the actual conditions of the proposed site.

## Manhole or Large Obstruction in Reinforced Soil Zone

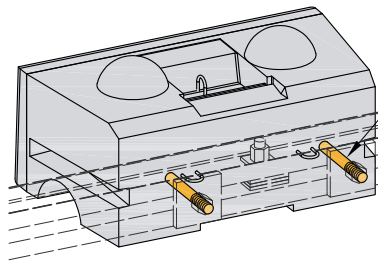
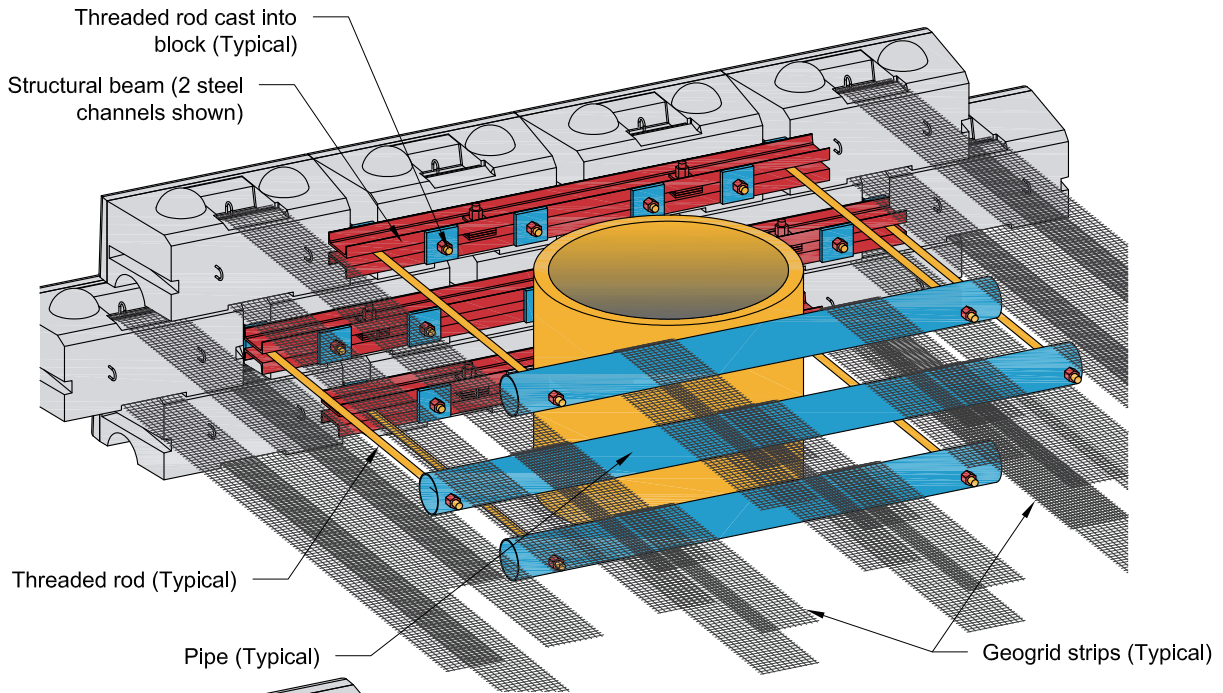

**Block Detail**

Steel structural elements to be sized and galvanized per engineer for project specific requirements.

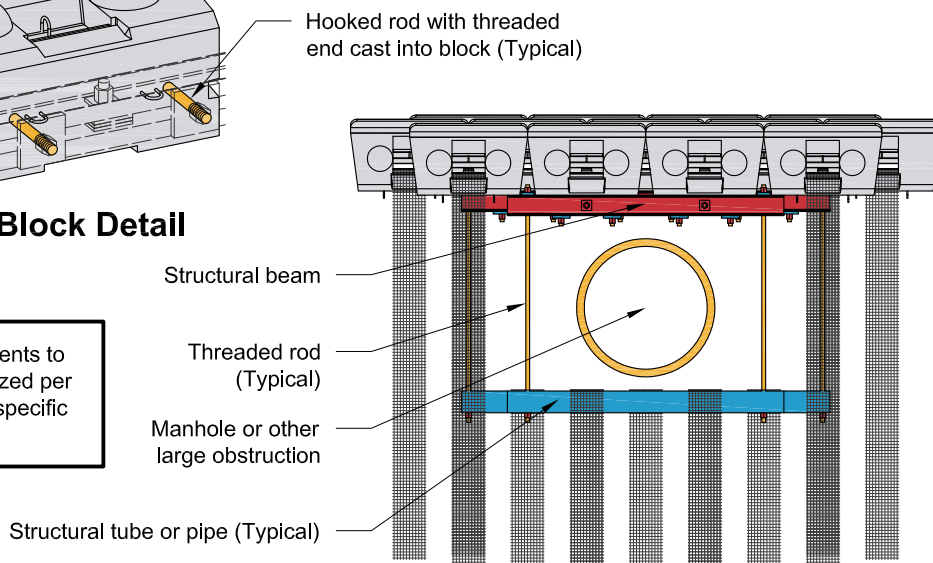

**Top View**

This drawing is for reference only. Determination of the suitability and/or manner of use of any details contained in this document is the sole responsibility of the design engineer of record. Final project designs, including all construction details, shall be prepared by a licensed professional engineer using the actual conditions of the proposed site.

### Utilities in the Reinforced Soil Zone

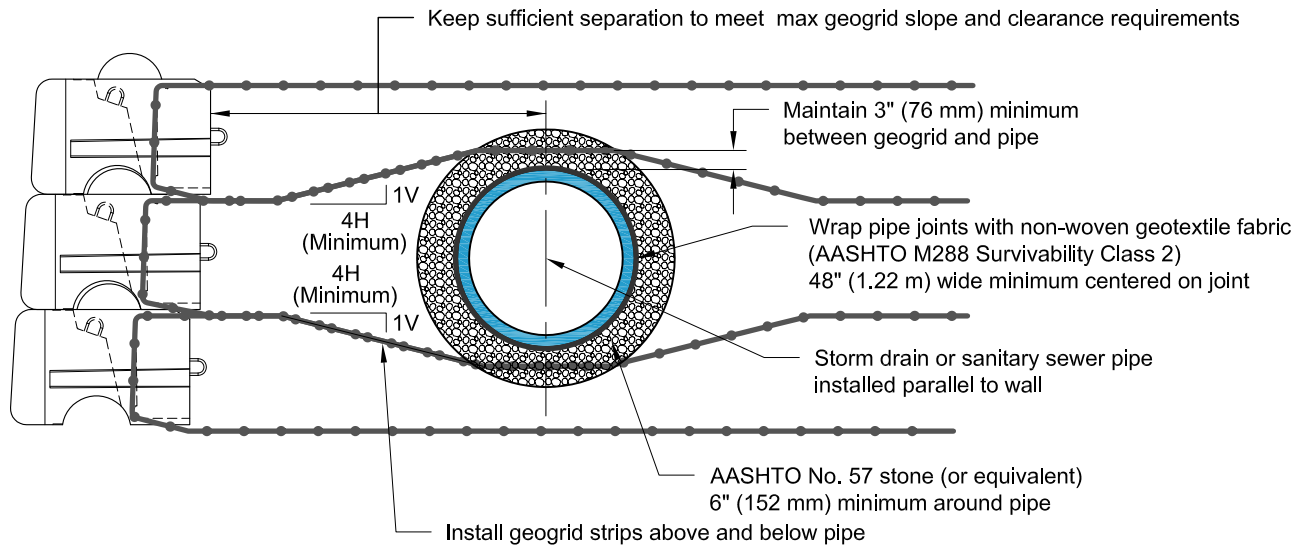

### Storm or Sanitary Sewer Pipe

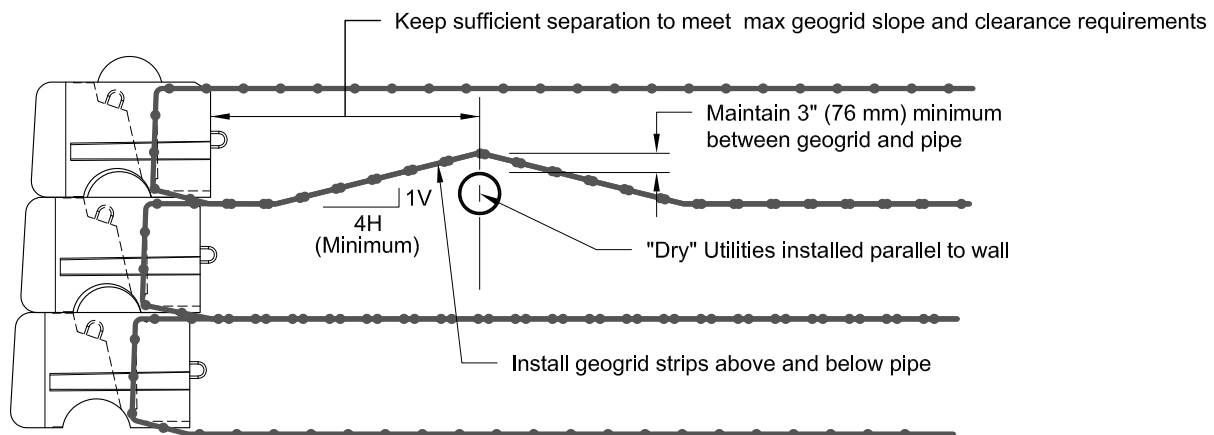

### "Dry" Utilities (Electric, Gas, Telecommunications)

Redi-Rock International follows the recommendations of FHWA GEC 011 and discourages placing pipes or other horizontal obstructions behind the wall in the reinforced soil zone. Placing pipes in this zone could lead to maintenance problems and potential wall failure.

This drawing is for reference only. Determination of the suitability and/or manner of use of any details contained in this document is the sole responsibility of the design engineer of record. Final project designs, including all construction details, shall be prepared by a licensed professional engineer using the actual conditions of the proposed site.

### Pipes Installed Through Wall - Perpendicular

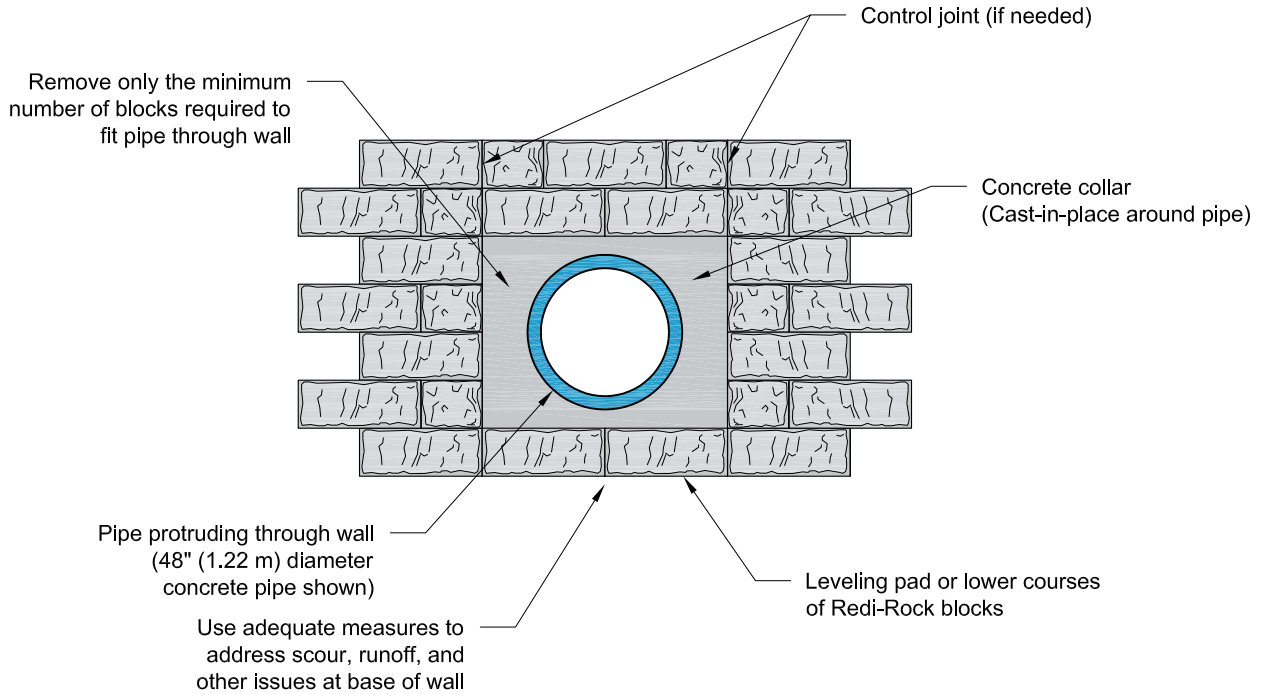

**Plan View**

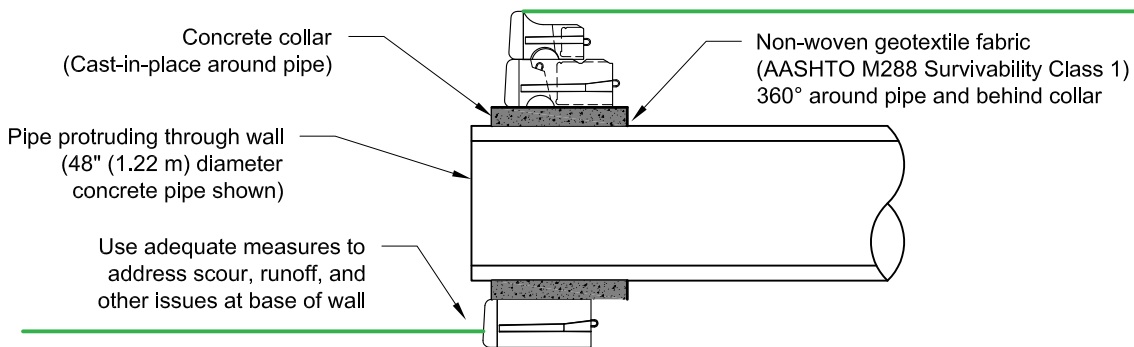

**Section View**

This drawing is for reference only. Determination of the suitability and/or manner of use of any details contained in this document is the sole responsibility of the design engineer of record. Final project designs, including all construction details, shall be prepared by a licensed professional engineer using the actual conditions of the proposed site.

### Common Fence or Pedestrian Guard Connections

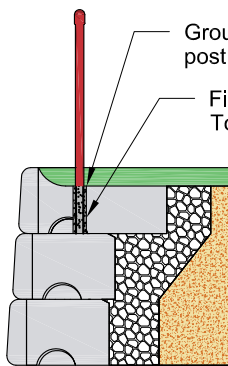
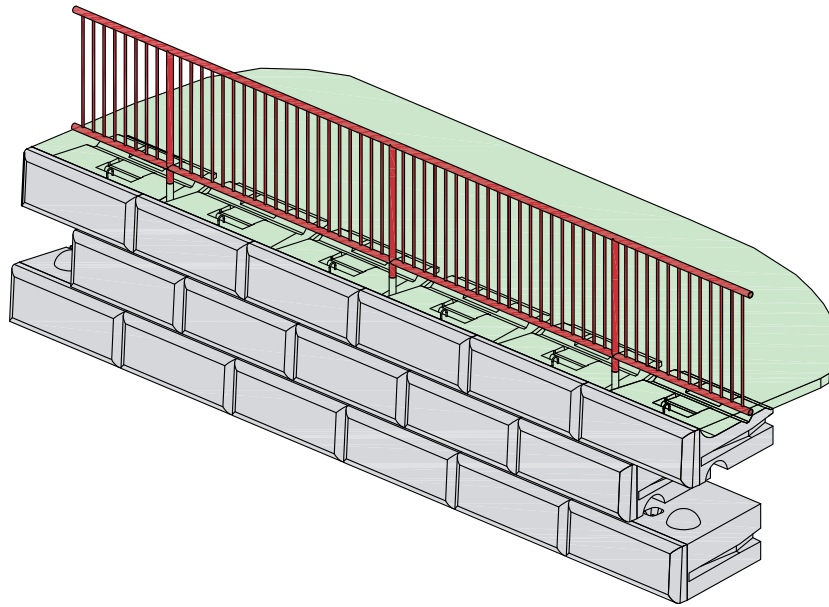

**Grouted Connection  
(1 Block)**

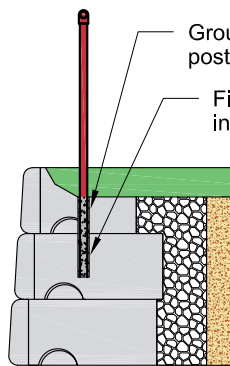

**Grouted Connection  
(2 Blocks)**

These generic pedestrian guard and fence details show a few potential options for their installation on the top of a Redi-Rock retaining wall. It is the design engineer's responsibility to fully design and detail the connection of the guard posts to the retaining wall blocks and assure acceptable resistance to the applied forces. Redi-Rock blocks are plain concrete, without steel reinforcement.

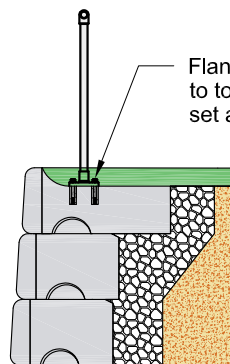

**Flange Bolted Connection**

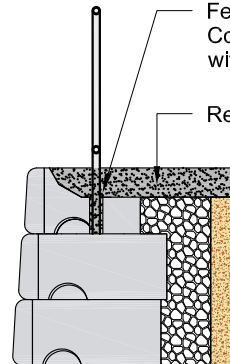

**Moment Slab Connection**

This drawing is for reference only. Determination of the suitability and/or manner of use of any details contained in this document is the sole responsibility of the design engineer of record. Final project designs, including all construction details, shall be prepared by a licensed professional engineer using the actual conditions of the proposed site.

### Common Fence or Pedestrian Guard Connection Locations

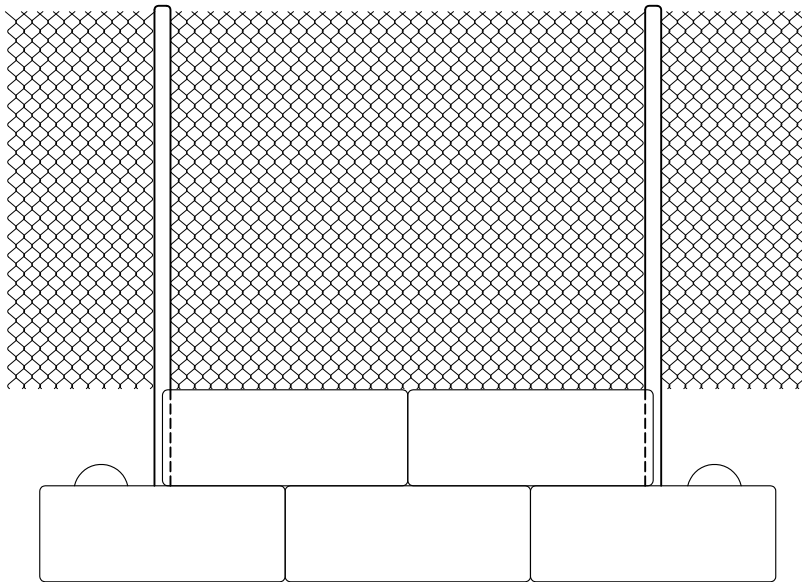

**Front View**

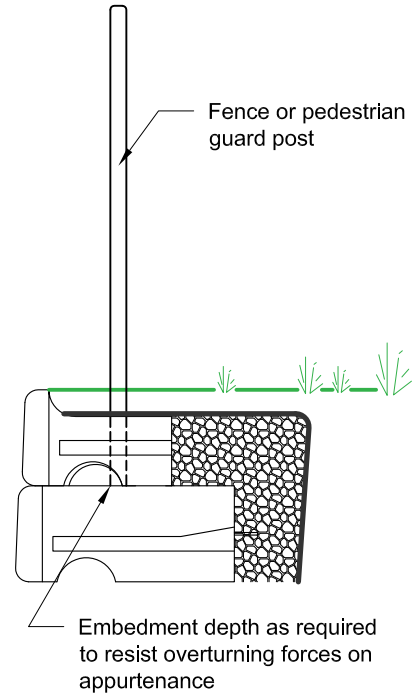

**Side View**

**Connection Option #1**  
Anchor into the top block

- Consider block lengths when determining post spacing
- Weight of a single block available to resist overturning forces

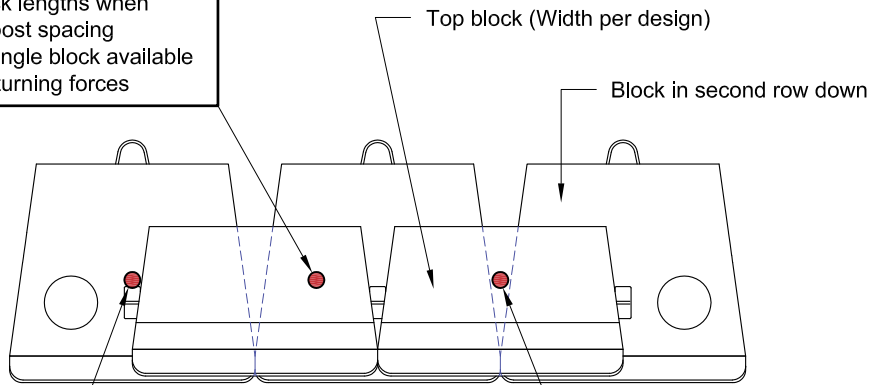

**Top View**

**Connection Option #2**  
Grout posts in v-shaped opening between top blocks

- Spacing in multiples of 46 1/8" (1172 mm)
- Weight of a 2 adjacent blocks available to resist overturning forces

**Connection Option #3**  
Core through top block and grout posts in V-shaped opening between lower blocks

- Spacing in multiples of 46 1/8" (1172 mm)
- Weight of a 2 adjacent blocks on second level down and 3 top row blocks available to resist overturning forces

This drawing is for reference only. Determination of the suitability and/or manner of use of any details contained in this document is the sole responsibility of the design engineer of record. Final project designs, including all construction details, shall be prepared by a licensed professional engineer using the actual conditions of the proposed site.

### Cast-in-Place Moment Slab Traffic Barrier - Flat Grade Installation

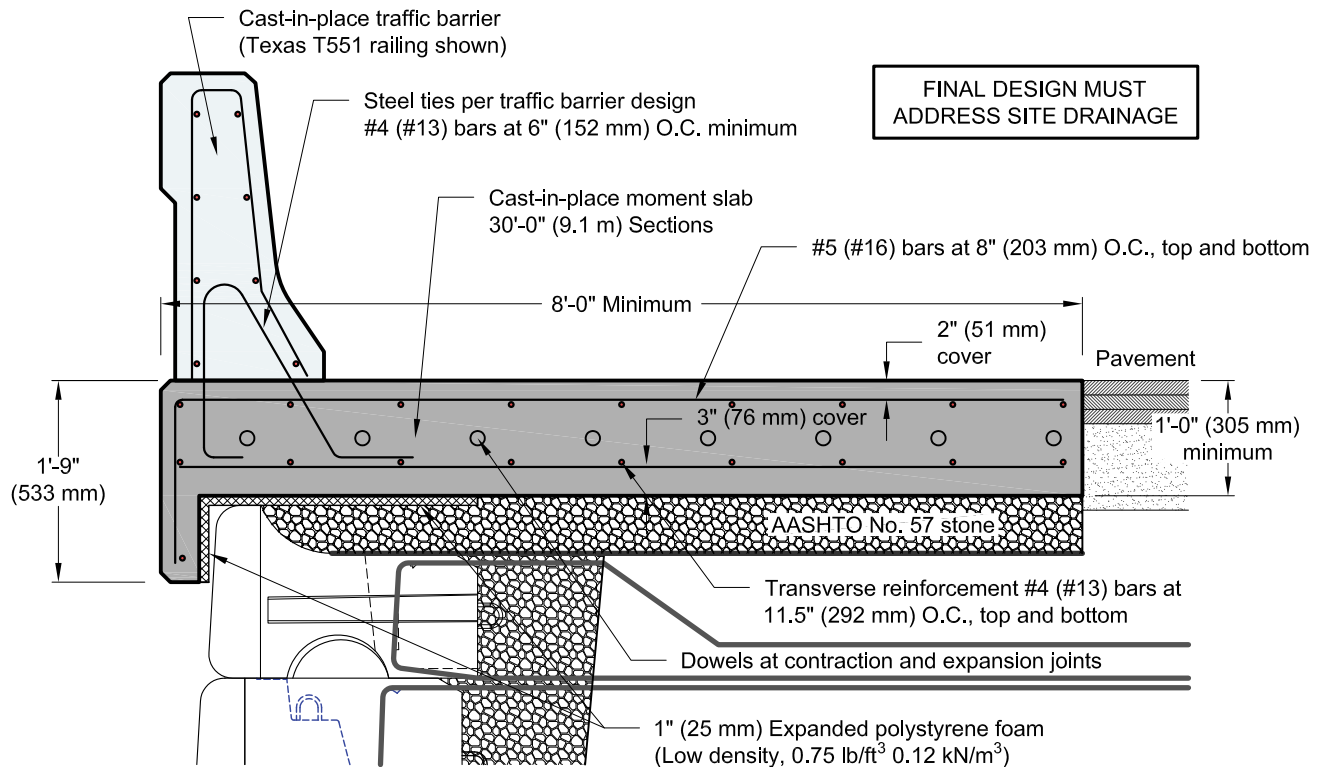

Expansion joints shall be provided in moment slab every 90'-0" (27.4 m). Expansion joint shall be dot standard detail. Typical features shown for reference.

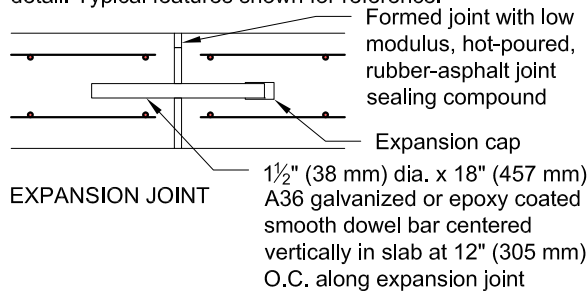

EXPANSION JOINT

Contraction joints shall be provided in moment slab every 30'-0" (9.1 m) between expansion joints. Contraction joint shall be dot standard detail. Typical features shown for reference.

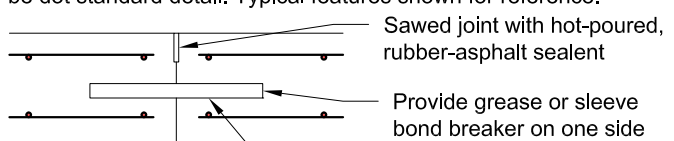

CONTRACTION JOINT

**Materials**

Concrete for cast-in-place barrier and moment slab shall be dot standard structure mix. Minimum 28 day compressive strength shall be 4,000 psi (27.6 mpa) or higher as specified. Reinforcing steel shall conform to ASTM A706 or AASHTO M31 Grade 60 (420 MPa).

**Design**

Moment slab shown is dimensioned based on an equivalent static load of 10,000 lbs (44.5 kN) per NCHRP Report 663. Moment slab reinforcement shown is based on *AASHTO LRFD Bridge Design Specifications, 5th edition, 2010, TL-4* loading detailed in Table A13.2.1.

The selection and use of this detail, while designed in accordance with generally accepted engineering principles and practices, is the sole responsibility of the registered professional engineer in charge of the project.

This drawing is for reference only. Determination of the suitability and/or manner of use of any details contained in this document is the sole responsibility of the design engineer of record. Final project designs, including all construction details, shall be prepared by a licensed professional engineer using the actual conditions of the proposed site.

### Cast-in-Place Moment Slab Traffic Barrier - Sloping Installation

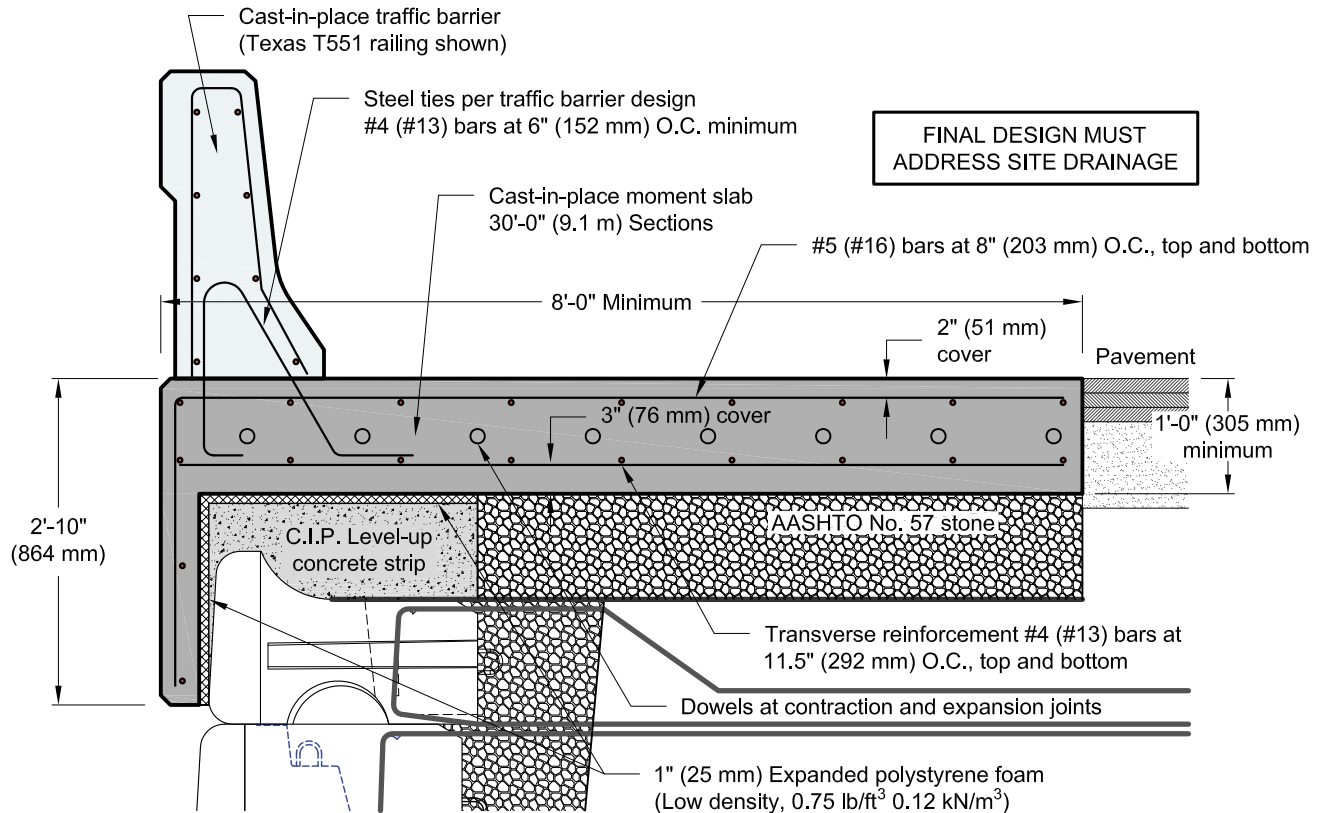

Expansion joints shall be provided in moment slab every 90'-0" (27.4 m). Expansion joint shall be dot standard detail. Typical features shown for reference.

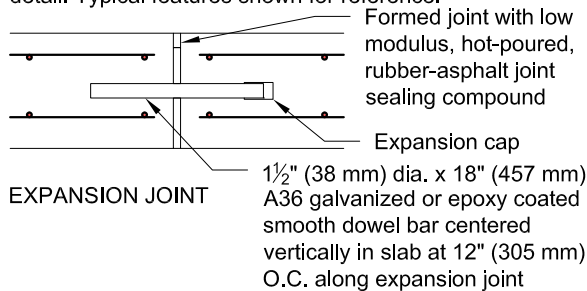

EXPANSION JOINT

Contraction joints shall be provided in moment slab every 30'-0" (9.1 m) between expansion joints. Contraction joint shall be dot standard detail. Typical features shown for reference.

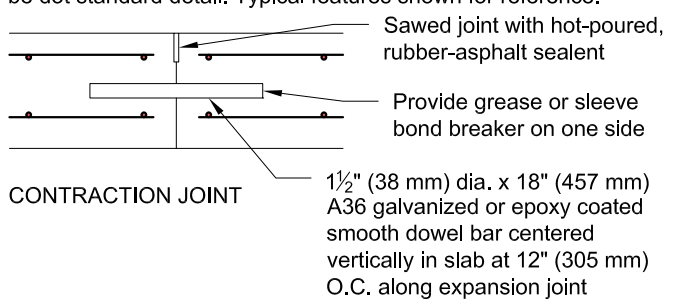

CONTRACTION JOINT

**Materials**

Concrete for cast-in-place barrier and moment slab shall be dot standard structure mix. Minimum 28 day compressive strength shall be 4,000 psi (27.6 mpa) or higher as specified. Cast-In-Place level up concrete shall be manufactured in accordance with ASTM C94. Minimum 28 day compressive strength shall be 3,500 psi (24.1 MPa) or higher as specified. Reinforcing steel shall conform to ASTM A706 or AASHTO M31 Grade 60 (420 MPa).

**Design**

Moment slab shown is dimensioned based on an equivalent static load of 10,000 lbs (44.5 kN) per NCHRP Report 663. Moment slab reinforcement shown is based on *AASHTO LRFD Bridge Design Specifications, 5th edition, 2010, TL-4* loading detailed in Table A13.2.1.

The selection and use of this detail, while designed in accordance with generally accepted engineering principles and practices, is the sole responsibility of the registered professional engineer in charge of the project.

This drawing is for reference only. Determination of the suitability and/or manner of use of any details contained in this document is the sole responsibility of the design engineer of record. Final project designs, including all construction details, shall be prepared by a licensed professional engineer using the actual conditions of the proposed site.

### Precast Barrier Block

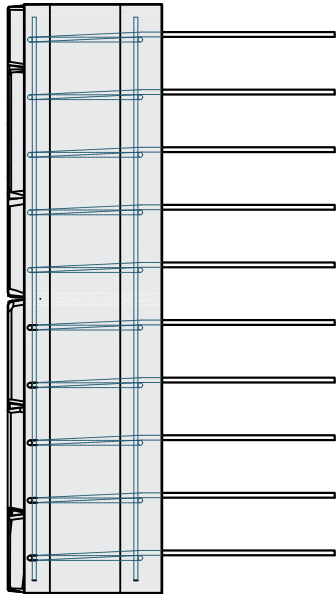

**Top View**

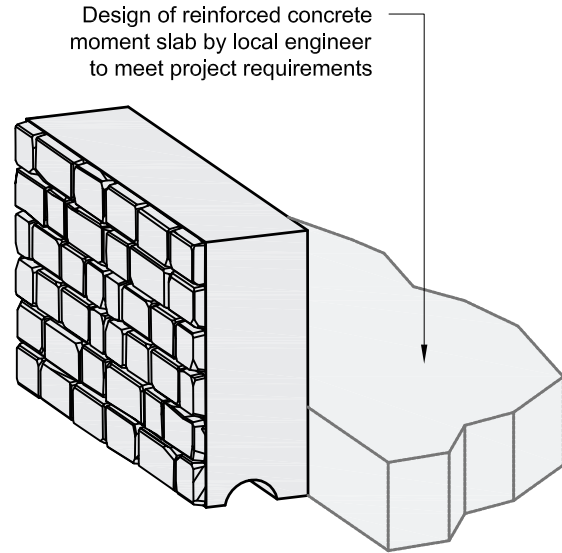

**Isometric View**

Rebar shown in barrier block meets AASHTO TL-3 loading requirements. Rebar design in barrier block is intended to be modified as necessary to meet other loading conditions. All reinforcing steel shall be grade 60 (414 MPa) deformed rebar. All concrete shall have a minimum 28 day compressive strength of 4000 psi (27.6 MPa).

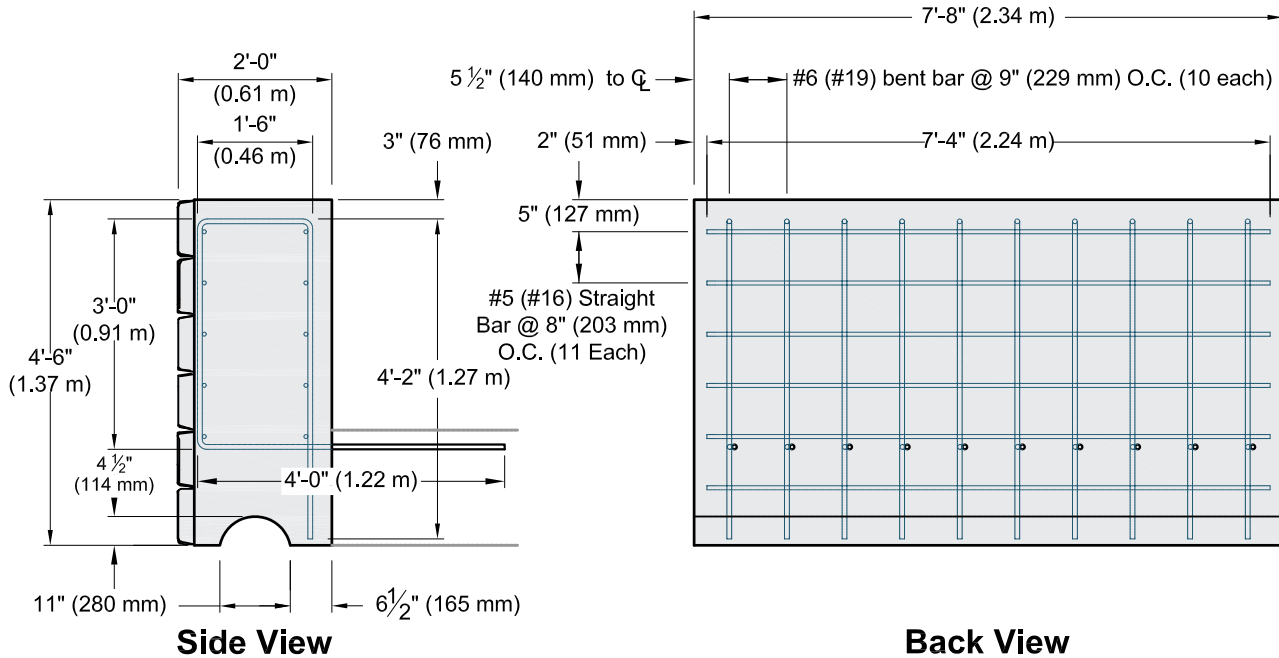

**Side View**

**Back View**

This drawing is for reference only. Determination of the suitability and/or manner of use of any details contained in this document is the sole responsibility of the design engineer of record. Final project designs, including all construction details, shall be prepared by a licensed professional engineer using the actual conditions of the proposed site.

### Post and Beam Guardrail

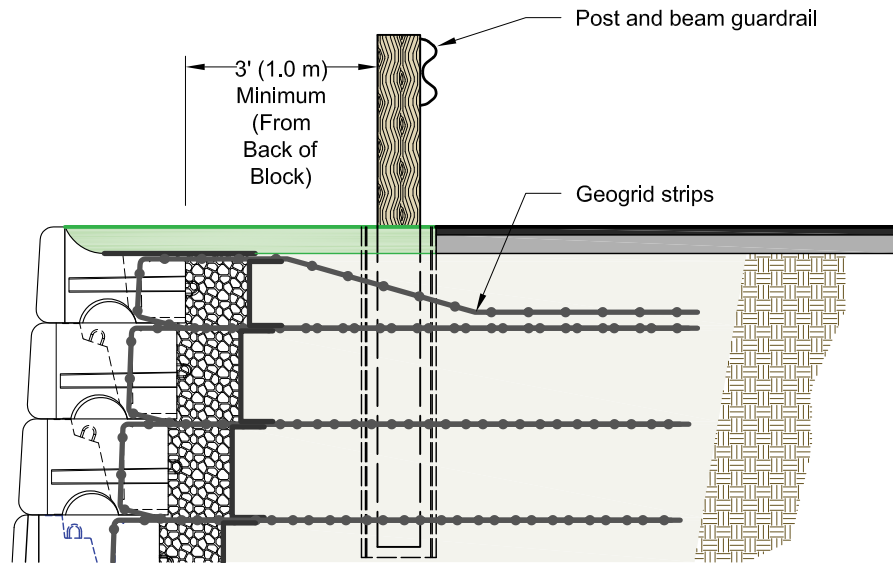

Section View

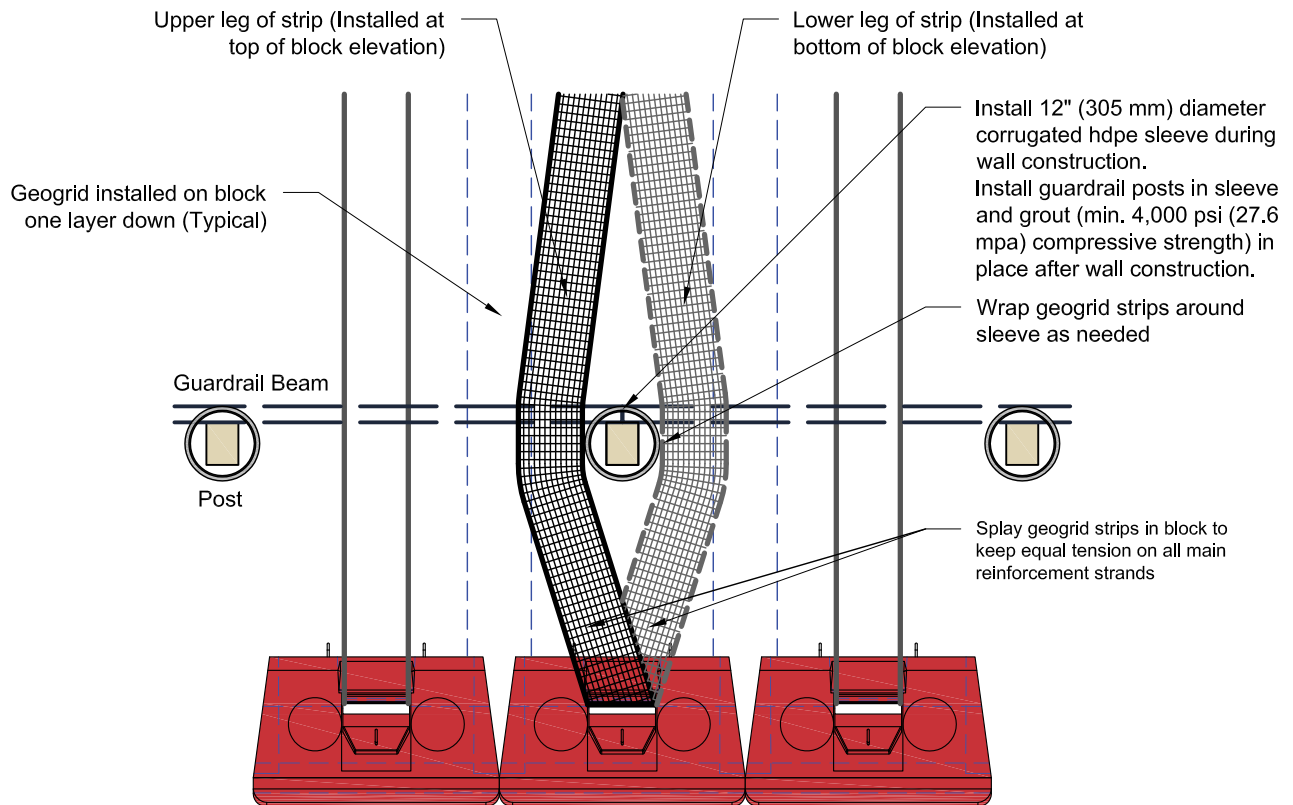

Top View

This drawing is for reference only. Determination of the suitability and/or manner of use of any details contained in this document is the sole responsibility of the design engineer of record. Final project designs, including all construction details, shall be prepared by a licensed professional engineer using the actual conditions of the proposed site.





Every Redi-Rock Distributor/Manufacturer  
is independently owned and operated.